

Metates Sulphide Heap Leach Project Phase 1



NI 43-101 Technical Report Preliminary Economic Assessment Durango, Mexico

Prepared For:



Qualified Persons:

Justin M. Black, PE
Art S. Ibrado, PhD, PE
Michael G. Hester, FAusIMM
Richard K. Zimmerman, MSc, RG, SME-RM

DATE AND SIGNATURES PAGE

The effective date of this report is 30 August 2021. See Appendix A, Prefeasibility Study Contributors and Professional Qualifications, for certificates of qualified persons.

(Signed) "*Justin M. Black*" _____ August 30, 2021
Justin M. Black, PE Date

(Signed) "*Art S. Ibrado*" _____ August 30, 2021
Art S. Ibrado, PhD, PE Date

(Signed) "*Michael G. Hester*" _____ August 30, 2021
Michael G. Hester, FAusIMM Date

(Signed) "*Richard K. Zimmerman*" _____ August 30, 2021
Richard K. Zimmerman, MSc, RG, SME-RM Date

METATES PROJECT
FORM 43-101F1 TECHNICAL REPORT

TABLE OF CONTENTS

SECTION	PAGE
DATE AND SIGNATURES PAGE.....	I
TABLE OF CONTENTS.....	II
LIST OF FIGURES AND ILLUSTRATIONS.....	IX
LIST OF TABLES.....	XI
1 SUMMARY.....	1
1.1 KEY DATA.....	1
1.2 PROPERTY DESCRIPTION AND LOCATION.....	3
1.3 HISTORY.....	5
1.4 GEOLOGICAL SETTING AND DEPOSIT TYPE.....	5
1.4.1 Geology.....	5
1.4.2 Mineralization.....	6
1.5 EXPLORATION STATUS, DRILLING, SAMPLE PREPARATION AND SECURITY.....	7
1.5.1 Exploration and Drilling.....	7
1.5.2 Sample Preparation, Security and Verification.....	8
1.6 MINERAL PROCESSING AND METALLURGICAL TESTING.....	9
1.6.1 Comminution Indices.....	9
1.6.2 Leach Test on Non-Oxidized Samples.....	9
1.6.3 Current Metallurgical Testing.....	10
1.6.4 Agitated Oxidation and Leach Tests.....	10
1.6.5 Column Oxidation and Leach Sighter Tests.....	11
1.6.6 Metallurgical Testing Plan for Prefeasibility Study.....	12
1.6.7 Gold and Silver Recoveries.....	12
1.7 MINERAL RESOURCE.....	12
1.8 MINING METHODS.....	13
1.9 RECOVERY METHODS.....	16
1.9.1 Oxidation Pad Operations.....	16
1.9.2 Cyanide Heap Leaching and Merrill-Crowe Plant.....	18
1.9.3 Reagents, Water and Power Consumption.....	18
1.10 PROJECT INFRASTRUCTURE.....	18
1.10.1 Site Layouts.....	18
1.10.2 Access Roads.....	19
1.10.3 Water Supply, Reservoir, and Distribution.....	20
1.10.4 Power Supply and Distribution.....	20
1.11 ENVIRONMENTAL STUDIES, PERMITTING AND SOCIAL AND COMMUNITY IMPACTS.....	20

1.12	CAPITAL COST SUMMARY	21
1.13	OPERATING COST SUMMARY	22
1.14	ECONOMIC ANALYSIS.....	23
1.15	CONCLUSIONS AND RECOMMENDATIONS	25
1.15.1	Conclusions.....	25
1.15.2	Recommendations.....	25
2	INTRODUCTION	26
2.1	PURPOSE OF REPORT	26
2.2	SOURCES OF INFORMATION	26
2.3	TERMS OF REFERENCE	27
3	RELIANCE ON OTHER EXPERTS	29
4	PROPERTY DESCRIPTION AND LOCATION	30
4.1	PROPERTY LOCATION	30
4.2	LAND AREA AND MINING CONCESSION DESCRIPTION	30
4.3	AGREEMENTS AND ENCUMBRANCES.....	33
5	ACCESSIBILITY, CLIMATE, LOCAL RESOURCES, INFRASTRUCTURE AND PHYSIOGRAPHY	35
5.1	ACCESS	35
5.2	CLIMATE	35
5.3	LOCAL RESOURCES.....	35
5.4	INFRASTRUCTURE	35
5.5	PHYSIOGRAPHY	36
6	HISTORY	37
7	GEOLOGICAL SETTING AND MINERALIZATION	39
7.1	REGIONAL GEOLOGY	39
7.2	LOCAL GEOLOGY.....	39
7.3	STRUCTURE	44
7.4	ALTERATION	44
7.5	MINERALIZATION.....	44
8	DEPOSIT TYPES	46
9	EXPLORATION.....	48
9.1	PRE-CAMBIOR EXPLORATION	48
9.2	CAMBIOR EXPLORATION	48
9.3	CHESAPEAKE EXPLORATION.....	49
10	DRILLING.....	50

10.1	GENERAL	50
10.2	PRE-CAMBIOR DRILLING	50
10.3	CAMBIOR DRILLING	50
10.4	CHESAPEAKE DRILLING	51
10.5	SAMPLING	52
	10.5.1 General	52
	10.5.2 Sample Lengths and Size	52
	10.5.3 Conclusion	52
11	SAMPLE PREPARATION, ANALYSES AND SECURITY	57
11.1	CAMBIOR SAMPLES	57
11.2	CHESAPEAKE SAMPLES	58
11.3	CAMBIOR QA/QC PROGRAMS	59
11.4	CHESAPEAKE QA/QC PROGRAM	59
	11.4.1 Chesapeake Drilling Data	59
11.5	REVIEW OF CAMBIOR DRILLING AND QA/QC DATA	62
11.6	CONCLUSIONS	63
12	DATA VERIFICATION	64
13	MINERAL PROCESSING AND METALLURGICAL TESTING	66
13.1	PREVIOUS METALLURGICAL TESTING	67
	13.1.1 Comminution Indices	67
	13.1.2 Leach Tests on Non-Oxidized Samples	67
13.2	CURRENT METALLURGICAL TESTING	68
	13.2.1 Agitated Oxidation and Leach Tests	68
	13.2.2 Column Oxidation and Leach Sighter Tests	69
13.3	2021 METALLURGICAL DRILLING	70
13.4	METALLURGICAL TESTING PLAN	73
13.5	GOLD AND SILVER RECOVERIES	73
13.6	OTHER METALLURGICAL TESTS	73
14	MINERAL RESOURCE ESTIMATES	74
14.1	MINERAL RESOURCE	74
14.2	DESCRIPTION OF THE RESOURCE MODEL	77
	14.2.1 General	77
	14.2.2 Database and Compositing	77
	14.2.3 Lithology Controls	79
	14.2.4 Structural Controls	82
	14.2.5 Grade Estimation	83
	14.2.6 Resource Classification	92

	14.2.7	Bulk Density	95
	14.2.8	Sensitivity to Grade Capping	95
	14.2.9	Comparison of the Current and Prior Mineral Resource Estimate	96
15		MINERAL RESERVE ESTIMATES	99
16		MINING METHODS	100
	16.1	OPERATING PARAMETERS AND CRITERIA	100
	16.2	PIT SLOPE ANGLES.....	100
	16.3	ECONOMIC PARAMETERS.....	103
	16.4	MINING PHASES	103
	16.5	MINE PRODUCTION SCHEDULE	108
	16.6	WASTE STORAGE AND STOCKPILES	111
	16.7	MINING EQUIPMENT	113
17		RECOVERY METHODS.....	115
	17.1	OXIDATION PAD OPERATIONS.....	115
	17.1.1	Crushing.....	115
	17.1.2	Oxidation On-Off Pad	118
	17.1.3	Conveying, Stacking and Oxidized Material Retrieval.....	118
	17.1.4	Oxidation.....	119
	17.1.5	Solution Regeneration	119
	17.2	CYANIDE HEAP LEACHING	120
	17.3	GOLD AND SILVER RECOVERY BY MERRILL-CROWE AND REFINERY	120
	17.4	REAGENTS.....	121
	17.5	CONTROL SYSTEMS.....	121
	17.6	ASSAY AND METALLURGICAL LABORATORIES	122
	17.7	WATER CONSUMPTION	122
	17.8	POWER CONSUMPTION	122
18		PROJECT INFRASTRUCTURE.....	123
	18.1	SITE LAYOUTS	123
	18.2	ACCESS ROADS.....	124
	18.3	COMMUNICATIONS	126
	18.4	WATER RESOURCES AND SYSTEMS.....	126
	18.4.1	Water Rights	126
	18.4.2	Surface Water Rights	127
	18.4.3	Groundwater Exploitation and Development of Water Rights	127
	18.4.4	Project-Wide Water Balance.....	128
	18.4.5	Mine Pit Diversion Dam and Tunnel.....	128
	18.4.6	Rio San Juan de Camarones Water Storage Dam and Reservoir	128

18.5	POWER SUPPLY	131
18.6	GEOCHEMICAL STUDIES OF MINE WASTE ROCK	132
18.6.1	Waste Rock Static Geochemical Tests Results.....	132
18.6.2	Waste Rock Kinetic Geochemical Test Results	134
18.6.3	Summary of Waste Rock Geochemical Testing	139
18.6.4	Summary of Waste Rock Material Geochemistry Characteristics	139
18.6.5	Implications for Closure.....	140
18.6.6	Pit Lake Model and Closure.....	140
18.7	RECLAMATION AND CLOSURE AT THE METATES SITE	142
18.7.1	Other Engineered Facilities	143
18.7.2	Closure	143
19	MARKET STUDIES AND CONTRACTS	145
19.1	GOLD AND SILVER DORÉ	145
19.2	SALES CONTRACTS	145
20	ENVIRONMENTAL STUDIES, PERMITTING AND SOCIAL OR COMMUNITY IMPACT	146
20.1	PROJECT LOCATION	146
20.2	CLIMATOLOGY	146
20.3	GEOLOGICAL RISK.....	147
20.4	AIR QUALITY	147
20.5	SURFACE WATER FLOWS	147
20.6	VEGETATION	150
20.6.1	Flora Management Plan	150
20.7	WILDLIFE	151
20.7.1	Wildlife Management Plan	151
20.8	ENVIRONMENTAL CONSERVATION AREAS CLOSE TO THE PROJECT	152
20.9	SOCIO-ECONOMIC BACKGROUND	152
20.10	CULTURAL AND HISTORICAL ASPECTS.....	153
20.11	PERMITTING CONSIDERATIONS STATUS	153
20.11.1	Permits	153
20.12	SURFACE AND GROUNDWATER INVESTIGATIONS	159
20.12.1	Surface Water Investigations	159
20.12.2	Groundwater Investigations	162
20.12.3	Hydrogeologic Modeling.....	164
20.13	RECLAMATION AND CLOSURE.....	166
21	CAPITAL AND OPERATING COSTS	167
21.1	CAPITAL COST	167

21.1.1	Currency.....	167
21.1.2	Scope.....	167
21.1.3	Metates Mine Capital Basis	168
21.1.4	Metates Process Plant Capital Basis	169
21.1.5	Water Supply	169
21.1.6	Sustaining Capital, Reclamation and Closure	170
21.2	OPERATING COST	170
21.2.1	Operating Cost Summary	170
21.2.2	Scope.....	170
21.2.3	Metates Mine Operating Cost.....	171
21.2.4	Metates Process Plant Operating Costs.....	175
21.3	SUPPORT FACILITIES	176
22	ECONOMIC ANALYSIS	177
22.1	INTRODUCTION.....	177
22.2	MINE PRODUCTION STATISTICS.....	177
22.3	PLANT PRODUCTIONS STATISTICS	177
22.4	MARKETING RETURN FACTORS	177
22.5	CAPITAL EXPENSES	177
22.5.1	Owner's Costs.....	178
22.5.2	Working Capital.....	178
22.5.3	Sustaining Capital.....	178
22.6	CASH OPERATING COST	179
22.7	RECLAMATION AND CLOSURE COST AND SALVAGE VALUE	179
22.8	DEPRECIATION	179
22.9	TAXATION	179
22.10	MINING ROYALTIES	180
22.11	FINANCIAL RESULTS	180
22.12	SENSITIVITY ANALYSIS.....	180
22.13	LEVERAGED-CASE.....	182
22.14	COMPARISON BETWEEN THE 2016 PFS AND THIS PEA	182
23	ADJACENT PROPERTIES	184
24	OTHER RELEVANT DATA AND INFORMATION.....	185
24.1	PROJECT EXECUTION PLAN	185
24.1.1	Summary	185
24.1.2	Future Technical Reports	185
24.1.3	Access Roads	185
24.1.4	Water Storage.....	185
24.1.5	Permitting.....	186

25	INTERPRETATION AND CONCLUSIONS	187
25.1	PROPERTY DESCRIPTION AND HISTORY	187
25.2	MINERAL RESOURCE	187
25.3	MINING.....	187
25.4	METALLURGY.....	188
25.4.1	Oxidation Tests	188
25.5	METAL RECOVERY	188
25.5.1	Gold and Silver Recovery	188
25.6	WASTE MANAGEMENT, RECLAMATION AND CLOSURE.....	188
25.7	PROJECT FINANCIALS.....	188
25.8	CONCLUSIONS	191
26	RECOMMENDATIONS.....	192
26.1	EXPLORATION, GEOLOGY AND DRILLING	192
26.2	RESOURCE MODEL UPDATE	192
26.3	METALLURGY.....	192
26.3.1	Oxidation and Recovery Testing	192
26.3.2	Preg-Borrowing Materials and Future Outlook.....	193
26.4	PROCESS FACILITIES	193
26.4.1	Geotechnical Investigations.....	193
26.4.2	Materials Take Offs	193
26.4.3	Capital and Operating Cost Estimates.....	193
26.5	INFRASTRUCTURE	194
26.5.1	Access Roads	194
26.5.2	Electric Power	194
26.5.3	Water.....	194
26.6	OTHER	194
26.6.1	Preferred Development Option	194
26.6.2	Environmental Baseline	195
26.6.3	Stakeholder Engagement	195
27	REFERENCES	196
	APPENDIX A: FEASIBILITY STUDY CONTRIBUTORS AND PROFESSIONAL QUALIFICATIONS	202

LIST OF FIGURES AND ILLUSTRATIONS

FIGURE	DESCRIPTION	PAGE
Figure 1-1:	Metates Project Location Map	4
Figure 1-2:	Column of Intrusive Composite Sample Under Oxidation	11
Figure 1-3:	Waste Storage Areas and Stockpiles, IMC 2021.....	15
Figure 1-4:	Simplified Flow Sheet of the Metates Sulphide Heap Leach Project.....	17
Figure 1-5:	General Arrangement of Open Pit, Stockpile and Waste Rock Dumps and Process Facilities.....	19
Figure 1-6:	Sensitivity of Pre-Tax NPV @ 5% to Metal Prices, Operating Cost, Capital Cost and Recovery.....	24
Figure 1-7:	Sensitivity of Pre-Tax IRR to Metal Prices, Operating Cost, Capital Cost and Recovery.....	24
Figure 4-1:	Site Location Map	31
Figure 4-2:	Mining Concessions in the Metates Area	32
Figure 7-1:	Regional Geology, Chesapeake 2016	39
Figure 7-2:	Geology of the Metates Area, Chesapeake 2016.....	41
Figure 7-3:	Geology of the Metates Pit Area, Chesapeake 2016.....	42
Figure 7-4:	Geology and Mineralization on Cross Section 10,300E, Chesapeake 2021	43
Figure 10-1:	Drillhole Locations, Chesapeake 2021	54
Figure 10-2:	Gold Grades on IMC Section 10, IMC 2014	55
Figure 10-3:	Silver Grades on IMC Section 10, IMC 2014.....	56
Figure 11-1:	Duplicates Sampling Scheme, GAI 2009.....	61
Figure 13-1:	Recovery vs Degree of Oxidation (red squares from POX tests in 2013)	66
Figure 13-2:	Column of Intrusive Composite Sample Under Oxidation	70
Figure 13-3:	Location of Five Metallurgical Drill Holes Relative to Previous Drilling, Chesapeake 2021.....	72
Figure 14-1:	Mineral Resource Cone Shell, IMC 2021	76
Figure 14-2:	Hole Locations by Drilling Campaign, IMC 2016	78
Figure 14-3:	Gold Grades in 15 m Composites by Model Lithology Type, IMC 2016.....	80
Figure 14-4:	Silver Grades in 15 m Composites by Model Lithology Type, IMC 2016.....	81
Figure 14-5:	Zinc Grades in 15 m Composites by Model Lithology Type, IMC 2016.....	82
Figure 14-6:	Structural Domains and Estimation Boundary, IMC 2016	83
Figure 14-7:	Gold Grades on Cross Section 10, IMC 2016	85
Figure 14-8:	Silver Grades on Cross Section 10, IMC 2016.....	87
Figure 14-9:	Gold vs. Sulphur – Intrusive Rock Types, IMC 2016.....	90
Figure 14-10:	Gold vs Sulphur – Sedimentary Rock Types, IMC 2016	91
Figure 14-11:	Resource Classification, IMC 2016.....	93

METATES SULPHIDE HEAP LEACH PROJECT - PHASE 1
FORM 43-101F1 TECHNICAL REPORT

Figure 14-12: Cross Section 10 Showing Resource Classification, IMC 2016	94
Figure 16-1: Inter-ramp Slope Angles, CNI 2012.....	102
Figure 16-2: Mining Phase 1, IMC 2021	104
Figure 16-3: Mining Phase 2, IMC 2021	105
Figure 16-4: Mining Phase 3, IMC 2021	106
Figure 16-5: Metates Final Pit (Phase 4), IMC 2021.....	107
Figure 16-6: Waste Storage Areas and Stockpiles, IMC 2021.....	112
Figure 17-1: Simplified Flow Sheet of the Metates Sulphide Heap Leach Project.....	116
Figure 17-2: General Arrangement of Open Pit, Stockpile and Waste Rock Dumps and Process Facilities.....	117
Figure 18-1: General Arrangement of Open Pit, Stockpile and Waste Rock Dumps and Process Facilities.....	123
Figure 18-2: Access Roads.....	125
Figure 18-3: San Juan de Camarones Dam and Reservoir Plan and Sections	130
Figure 18-4: Metates Proposed Power Line Alignment.....	131
Figure 18-5: Waste Rock Static Geochemical Data, ABA Data with NPR Criteria	133
Figure 18-6: Total Sulphur and NPR for 1997 HCT and 2014 HCT Samples.....	135
Figure 18-7: On-Site Column Data-Field and Lab pH, Total Alkalinity.....	138
Figure 18-8: Water Balance Components of Long-Term Closure for the 880 meter Elevation Pit Lake.....	141
Figure 18-9: Pit Lake Water Quality Modeling Results –pH.....	142
Figure 20-1: San Lorenzo River Watershed Above El Real.....	148
Figure 20-2: Streamflow and Precipitation in San Lorenzo Basin.....	149
Figure 20-3: Streamflow of San Lorenzo River at El Real	149
Figure 20-4: Natural Protected Areas (ANP Federales).....	152
Figure 20-5: Surface Water and Groundwater Sampling Locations as of 2012.....	161
Figure 20-6: Bedrock Geology and Interpreted Groundwater Elevations	163
Figure 20-7: Borehole Locations of Airlift and Slug Tests.....	165
Figure 20-8: Numerical Model Active Grid Area.....	166
Figure 22-1: Sensitivity of NPV 5% to Metal Prices, Operating Cost, Capital Cost, Overall Recovery.....	181
Figure 22-2: Sensitivity of IRR to Metal Prices, Operating Cost, Capital Cost, Overall Recovery	182
Figure 25-1: Sensitivity of NPV 5% to Metal Prices, Operating Cost, Capital Cost, Overall Recovery.....	189
Figure 25-2: Sensitivity of IRR to Metal Prices, Operating Cost, Capital Cost and Metal Recoveries	190

LIST OF TABLES

TABLE	DESCRIPTION	PAGE
Table 1-1:	Key Project Data	2
Table 1-2:	Summary of Drilling by Campaign	7
Table 1-3:	Measured Comminution Parameters for Metates Composites (by Hazen).....	9
Table 1-4:	Bottle Roll and Agitation Leach Tests on “Whole Ore” Samples and Rougher Flotation Concentrates	10
Table 1-5:	Baseline Leach Testing of Intrusive Composite Materials	11
Table 1-6:	Mineral Resource	13
Table 1-7:	Consolidated Mine and Process Facility Initial Capital Costs	22
Table 1-8:	Consolidated Operating Cost Summary	22
Table 1-9:	Financial Results Summary	23
Table 2-1:	List of Qualified Persons, Dates of Site Visits and Areas of Responsibility	27
Table 2-2:	Nomenclature and Units of Measure	28
Table 4-1:	Mining Concessions.....	30
Table 6-1:	Property History	38
Table 10-1:	Summary of Drilling by Campaign	50
Table 11-1:	GAI Recommended Gold Adjustments	63
Table 12-1:	Assay Summary of Chesapeake/Cambior Twin Holes	65
Table 13-1:	Head Assays of Composite Samples.....	67
Table 13-2:	Measured Comminution Parameters for Metates Composites (by Hazen).....	67
Table 13-3:	Bottle Roll and Agitation Leach Tests on “Whole Ore” Samples and Rougher Flotation Concentrates ...	68
Table 13-4:	Baseline Oxidation and Leach Tests on Intrusive Composite Materials	69
Table 13-5:	Baseline Oxidation and Leach Tests on the Sedimentary Composite Materials	69
Table 13-6:	PQ Diamond Core Drilling and Samples for Metallurgical Composites	71
Table 14-1:	Mineral Resource.....	75
Table 14-2:	Economic Parameters.....	75
Table 14-3:	Summary of Drilling by Campaign	77
Table 14-4:	Estimation Parameters.....	89
Table 14-5:	Specific Gravity Measurement by Rock Type	95
Table 14-6:	Cap Grades for Silver and Gold Assays	96
Table 14-7:	Comparison of 2021 versus 2016 Mineral Resource Estimate.....	97
Table 14-8:	Comparison of Parameters for Mineral Resource Estimates.....	98
Table 16-1:	Recommended Slope Angles, CNI 2012	101

METATES SULPHIDE HEAP LEACH PROJECT - PHASE 1
FORM 43-101F1 TECHNICAL REPORT

Table 16-2: Economic Parameters for Mine Design	103
Table 16-3: Mine Production Schedule	109
Table 16-4: Plant Production Schedule.....	110
Table 16-5: Mining Equipment	113
Table 17-1: List of Main Crushing Plant Equipment.....	115
Table 17-2: List of Conveying and Stacking Equipment for the Oxidation Pad.....	118
Table 17-3: List of Conveying and Stacking Equipment for the Dedicated Leach Pad.....	120
Table 17-4: Main Process Reagents.....	121
Table 18-1: Operating Loads	132
Table 18-2: Waste Rock Static ABA Geochemical Data Statistical Summary	133
Table 18-3: On-Site Column Construction Summary.....	134
Table 18-4: Summary Results of 2014 HCT Samples	136
Table 18-5: On-Site Column Leachate Water Quality Summary	137
Table 18-6: Summary of Mineralized Material and Waste Rock Generation	140
Table 20-1: Permits Matrix.....	156
Table 20-2: Groundwater Wells and Field Parameters.....	164
Table 21-1: Consolidated Mine and Process Facility Initial Capital Costs, US\$000	167
Table 21-2: Capital Cost Estimate Areas and Responsible Parties.....	168
Table 21-3: Mine Capital Cost – Contract Mining	169
Table 21-4: Summary of Direct Costs for the Mine and Processing Facilities	169
Table 21-5: Sustaining Capital Schedule.....	170
Table 21-6: Life of Mine Operating Cost Summary.....	170
Table 21-7: Operating Cost Estimate Areas and Responsible Parties	171
Table 21-8: Mine Operating Cost – Contract Mining.....	174
Table 21-9: Equipment Depreciation per Shift	175
Table 21-10: Mining Costs by Cost Center	175
Table 21-11: Summary of Operating Costs for Various Facilities	175
Table 21-12: Summary of Operating Costs for Support Facilities.....	176
Table 22-1: Life of Mine Mineralized Material Quantities and Mineralized Material Grade.....	177
Table 22-2: Life of Mine Metal Production	177
Table 22-3: Capital Cost Summary (US\$000).....	178
Table 22-4: Sustaining Capital Summary.....	178
Table 22-5: Cash Cost Summary.....	179
Table 22-6: Financial Results Summary	180

METATES SULPHIDE HEAP LEACH PROJECT - PHASE 1
FORM 43-101F1 TECHNICAL REPORT

Table 22-7: Sensitivity of NPV @ 5%, Pre-Tax.....	181
Table 22-8: Sensitivity of IRR, Pre-Tax.....	182
Table 25-1: Sensitivity of Pre-Tax NPV @ 5%, US\$000.....	189
Table 25-2: Sensitivity of Pre-Tax IRR, %.....	190

LIST OF APPENDICES

APPENDIX	DESCRIPTION
A	Feasibility Study Contributors and Professional Qualifications <ul style="list-style-type: none">• Certificates of Qualified Persons (“QP”)

1 SUMMARY

Chesapeake Gold Corp. (Chesapeake) commissioned M3 Engineering & Technology Corp. (M3) of Tucson, Arizona to prepare a preliminary economic assessment (PEA) of the Metates Sulphide Heap Leach Project - Phase 1 in Durango, Mexico, compliant with Canadian reporting regulations as defined in National Instrument 43-101 (NI 43-101). This PEA explores the viability of a two-stage heap leach process to recover gold and silver from intrusive and intrusive breccia materials that are parts of the Metates mineral resource.

Due to the partial refractoriness of the Metates materials, the two-stage process will include oxidation of the sulphides on an on-off pad, followed by conventional cyanide heap leaching process of the oxidized materials on a dedicated heap leach pad. The recoveries are projected to be lower compared to the pressure oxidation option but the process will not be as capital intensive.

The planned tonnage for operation is 15,000 tonnes per day (tpd) over 31 years, with potential to expand to 30,000 tpd.

1.1 KEY DATA

Key project parameters are presented in Table 1-1 including a summary of the project size, production, operating costs, metal prices, and financial indicators.

The results of this PEA are preliminary in nature. There is no certainty that the results of this PEA will be realized. Mineral resources that are not mineral reserves do not have demonstrated economic viability.

Table 1-1: Key Project Data

Mine Life	24 years			
Operation Life	31 years			
Mine Type:	Open Pit			
Process Description	Crushing, oxidation on an on-off pad, conventional cyanide heap leaching on a dedicated pad, Merrill-Crowe Au/Ag recovery			
Material Mined	Life of Mine ("LOM")			
Total Material Mined, kt	533,998			
Direct Feed to Process, kt	127,294			
Low-grade Stockpile, kt	38,797			
Waste Rock, kt	367,907			
Strip Ratio	2.22			
Average Stacking Rate, kt/year	5,358			
Metal Production				
Gold, kOz	2,824			
Silver, kOz	62,286			
Average Process Grades	Years 1-10	Years 11-20	Years 21-31	LOM Avg
Gold (g/t)	0.859	0.931	0.490	0.756
Silver (g/t)	23.18	11.22	12.75	15.71
Average Annual Production	Years 1-10	Years 11-20	Years 21-31	LOM Avg
Gold (k Oz)	104.8	114.7	57.1	91.1
Silver (k Oz)	3,004	1,467	1,598	2,009
Initial Capital Costs (US\$000)	\$359,209			
LOM Average Operating Costs	US\$/t processed			US\$/Oz Au
Total Cash Cost	\$11.66			\$685.97
Sustaining Capital, Reclamation & Closure	\$1.06			\$62.49
All-In Sustaining Cost (AISC)	\$12.72			\$748.46

Key PEA Financial Values	Low Case	Base Case	High Case (Spot)
Gold Price (US\$ per troy ounce)	\$1,360	\$1,600	\$1,786
Silver Price (US\$ per troy ounce)	\$19	\$22	\$26
USD:CDN Exchange Rate	1:1.25		
USD:MEX Exchange Rate	1:20.05		
Unlevered Pre-Tax Economic Indicators			
NPV at 5% Million C\$	\$896	\$1,427	\$1,906
NPV at 5% Million US\$	\$717	\$1,142	\$1,525
IRR %	25.3	35.4	45.2
Payback, years	3.4	2.5	2.0
Levered After-Tax Economic Indicators			
NPV at 5% Million C\$	\$509	\$852	\$1,162
NPV at 5% Million US\$	\$407	\$682	\$930
IRR %	26.9	41.2	55.9
Payback, years	3.4	2.2	1.6

1.2 PROPERTY DESCRIPTION AND LOCATION

The Metates mine site is in the northwestern part of Durango State, some 160 kilometers (km) northwest of the city of Durango and 175 km north of the coastal resort city of Mazatlán. Geographic coordinates of the Metates deposit area are 24°55'N latitude and 106°23'W longitude (Figure 1-1).

Topography at the Metates site is mountainous with elevations in the general region ranging from 620 meters (m) in the west near the village of San Juan de Camarones to 2,300 m along the ridge line to the southeast. Elevations in the immediate Metates Project area range from 650 to 1,180 m.

The Metates property is composed of twelve contiguous concessions totaling 4,261 hectares in area. These concessions are held in the name of American Gold Metates, S. de R.L. de C.V., an indirect 99.9%-owned subsidiary of Chesapeake. All of these concessions are in good standing with applicable taxes, payments, and filings being current.

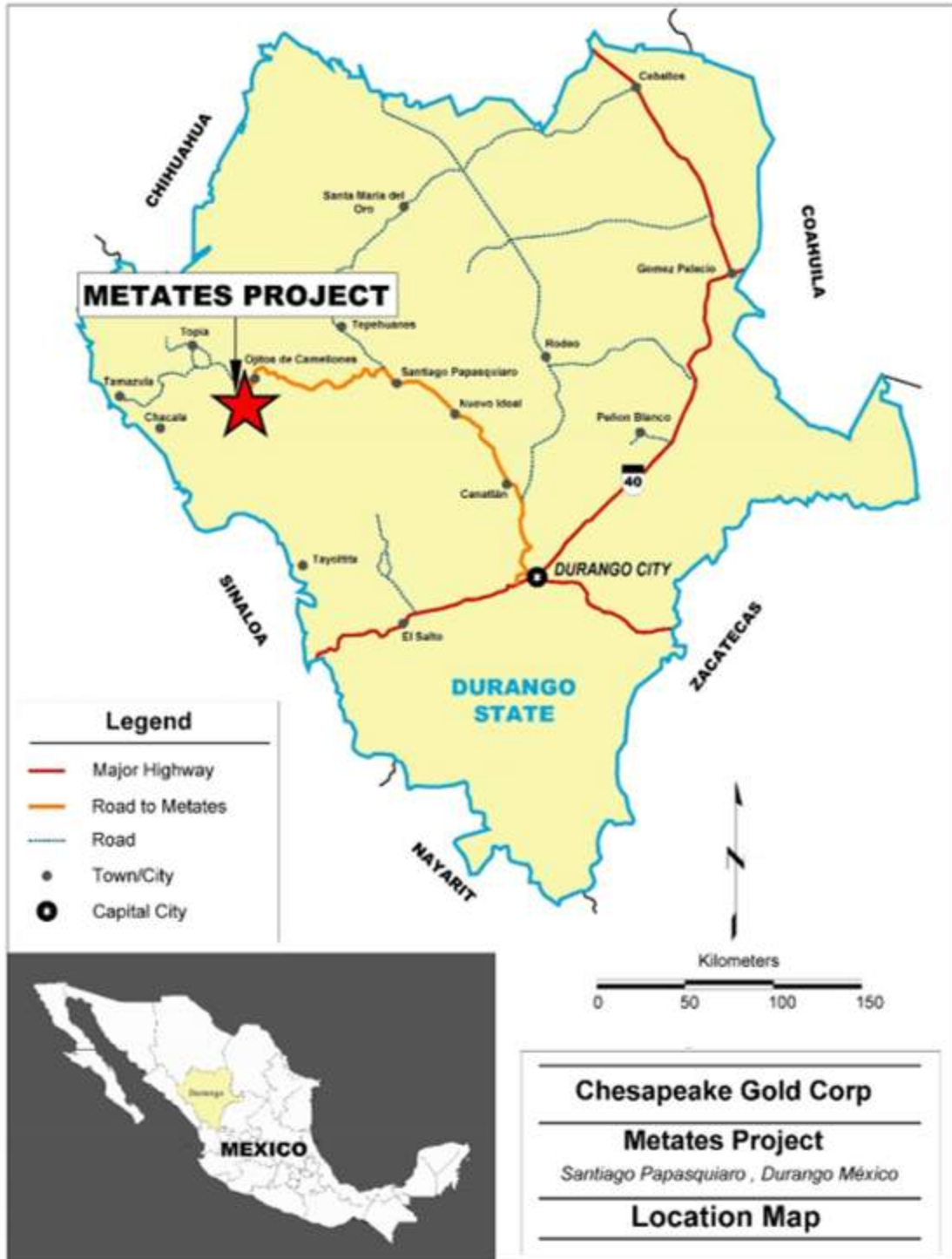

Figure 1-1: Metates Project Location Map

1.3 HISTORY

Exploration and mining at Metates trace back to the early Spanish colonial times of the 17th and 18th centuries. The first extensive work on the property is thought to be that of Sr. Roberto Erraguin, who developed at least one adit targeting mineralization in the sediments, and also possibly an adit into the intrusive hosted mineralization as well.

From 1980 to 1983, Minas Frisco and a subsidiary of British Petroleum ("Frisco/BP") followed up on the earlier work of Sr. Erraguin, drilling numerous holes that targeted primarily the sedimentary-hosted massive sulphide base metal-rich mineralization. The entire available core from this drilling was re-logged and assayed by Cambior.

In 1987, after the Frisco/BP venture returned the property to Sr. Erraguin, Luismin optioned the concessions. Luismin's early-stage exploration determined that the intrusive-hosted mineralization represented a large-tonnage, disseminated-type deposit. Luismin drilled four deep core holes in 1992 in the most geochemically anomalous area and intercepted significant lengths of continuously mineralized material with low-grade gold and silver.

In early 1993, Cambior and Luismin entered into a joint venture, whereby Cambior could earn an initial 50% of the property through a combination of exploration expenditures and the preparation of a feasibility study. Between 1993 and 1997, Cambior carried out extensive work on the Metates property, culminating in the preparation of a preliminary feasibility study, dated July 1997.

Since acquiring the Metates property in 2007, Chesapeake has completed extensive drilling and related assaying in order to validate the Cambior data and to allow for its incorporation into a succession of NI 43-101-compliant mineral resource estimates. In addition, Chesapeake and independent consultants have prepared several NI 43-101-compliant PEA technical reports and issued a preliminary feasibility study in March 2013 (2013 PFS), which was updated in April 2016. This PEA report examines a different approach to processing material using oxidative heap leaching, which would require lower capital and operating costs compared to the previous studies conducted by Chesapeake.

1.4 GEOLOGICAL SETTING AND DEPOSIT TYPE

1.4.1 Geology

The local geology shows the Metates Project is situated within a window of Mesozoic basement rocks exposed by erosion of the extensive flat-lying Tertiary volcanic cover. The basement complex of Cretaceous to Jurassic aged rocks consists of a monotonous sequence of interbedded sandstones, shales, and argillites. In general, the lower horizons are finer-grained and thinly bedded, with the grain size and bedding thickness tending to increase up section. The sedimentary package measures at least 1,000 m in exposed thickness, but the true thickness could be somewhat less, due to the presence of intra-formational thrust faulting and isoclinal folding. A variable amount of black carbonaceous material is present throughout the sequence, with organic carbon content ranging up to more than 1% locally. Pyrite is a common constituent of the sedimentary rocks and is commonly present as thin laminations, as disseminated framboidal biogenic pyrite, or as irregular veinlets or stockworks. Overall, pyrite content in the sedimentary rocks within the mineralized area is typically in the range of 3% to more than 10% but can be much higher locally. The stratigraphy is indicative of a submarine seafloor distal flysch depositional environment.

A preserved thickness of at least 160 m of conglomerate is present in the upper portion of the Mesozoic sedimentary sequence. The conglomerate ranges from rounded pebbles to boulders of sandstone and subordinate shale, chert, volcanic rock, and quartz fragments in a sandy-to-shaley, well-indurated matrix. The conglomeratic beds are often interbedded with arkose and argillite.

A felsic igneous body, interpreted to be a subvolcanic to extrusive volcanic dome, is generally broadly conformable with the enclosing sedimentary rocks and is referred to as the Metates Intrusive. The body is in the shape of an inverted saucer and is oriented in a northwest/southeast direction, dipping approximately 40° to the northeast. It is

approximately 1,500 m long and up to 300 m thick. The body is quartz latitic in composition and contains approximately 50% phenocrysts (quartz, biotite, and feldspars) set in an aphanitic groundmass. The rock exhibits a texture ranging from igneous to volcanic. Pyrite content in the Metates Intrusive, as in the surrounding sedimentary rocks, is typically in the range of 5% to more than 10%. The upper contact, or transition with the sediments, can be upwards of 100 m thick, and is composed predominantly of a breccia body that comprises often rounded igneous clasts and igneous-derived matrix, with a progressively larger amount of sedimentary matrix and sedimentary clasts going up section away from the core of the igneous body. Several radiometric age dates have been obtained from the Metates Intrusive. A U-Pb date has been obtained on a zircon separate and indicates an emplacement age of 108 million years ("Ma"). Ages of 87 and 89 Ma, which likely represent an alteration age, have been obtained on sericite by K/Ar methods.

The Tertiary sequence at Metates consists primarily of a regionally extensive Lower and Upper Volcanic Sequence. In the Metates area, the lower volcanics are a sequence of andesitic flows 100 to 150 m thick, and breccias which have been propylitically altered and are thought to postdate mineralization. A conglomerate of variable thickness (up to 60 m) is known to locally underlie the lower volcanic sequence rocks. This rock is distinct from the Mesozoic conglomerate but could be a local erosional accumulation of this unit. It does appear to be altered and mineralized, with local, possibly secondary enrichment of silver. The upper volcanics are composed of cliff-forming rhyolite ash flow tuff units, which are up to 700 m thick in the immediate vicinity of the project. Talus (or colluvial) deposits up to 50 m thick cover much of the project area and are derived predominantly from erosion of the upper volcanics.

1.4.2 Mineralization

Sulphide mineralization within the project area is thought to be both syngenetic and epigenetic in origin. Syngenetic mineralization is fairly widespread within the sedimentary rocks and is typical of rocks formed in a black-shale or euxinic environment. Very little, if any, precious metal mineralization is thought to be associated with this phase of predominantly pyritic mineralization. Epigenetic mineralization may have occurred as two separate mineralizing events in both the sedimentary rocks and in the intrusive rocks but it is possible that the mineralization in the sediments represents an earlier, more distal event that is related to an emerging intrusive dome, which subsequently intruded part of the sedimentary hosted mineralization.

Mineralization is most typically expressed as sulphide stockwork veinlets or disseminations. Within both the sedimentary and intrusive rocks, veinlets are typically composed almost completely of pyrite, sphalerite, arsenopyrite, and galena, with very little gangue mineralization such as quartz or calcite. Veinlets are typically between 1 to 5 millimeters (mm) in thickness, sometimes exceeding 1 cm, and are generally banded with layers of pyrite, sphalerite, and/or galena. Within the intrusive, feldspar and biotite phenocrysts are commonly replaced by pyrite and sphalerite, with the individual pyrite crystals generally several millimeters in size. Sphalerite and galena inclusions are common within disseminated and veinlet pyrite.

Extensive mineralogical investigations indicate that some amounts of native gold and electrum occur as both rare free mineral grains, as micron-sized grains that are generally enclosed within the pyrite grains, or as solid solution within the crystal structure of the pyrite in both sedimentary and intrusive host rocks. The majority of the gold is associated with pyrite either as solid solution or as inclusions although there is some amount of coarser, visible gold (>20 micron). Extensive metallurgical investigations have demonstrated that the gold is largely refractory or not amenable to routine cyanidation, even when the material is finely ground. Most silver mineralization is associated with the mineral pyrargyrite or as a solid solution within the copper mineral tetrahedrite. Commonly both of these minerals are found as inclusions within galena (AMTEL, 2020). These same metallurgical investigations show that silver is also refractory, but to a lesser degree than gold.

Gold and silver mineralization is associated with the sulphides replacing feldspar and biotite phenocrysts, with sulphide veinlets and sulphide stockworks. Sulphide sulphur content of mineralized sedimentary and intrusive rocks is typically in the range of 3% to more than 10% by weight, a reflection of the high percentage of pyrite in these rocks. The sedimentary rocks may also contain significant amounts of organic carbon, which results in the mineralization in these rocks having both refractory and mildly “preg-borrowing” characteristics. Preg-borrowing is when gold and silver, once extracted by cyanide, are then bound up with organic carbon, making them more difficult for routine recovery. Multiple mineralizing episodes are suggested based on the cross-cutting and mineralized breccia clast/host relationships. Oxidation of the Metates-mineralized system has been very limited, with the depth of oxidation generally not exceeding 5 to 10 m. Surficial exposures of fresh sulphides are not uncommon.

1.5 EXPLORATION STATUS, DRILLING, SAMPLE PREPARATION AND SECURITY

1.5.1 Exploration and Drilling

Following the limited amount of Luismin drilling in 1992 and shortly after the Cambior/Luismin joint venture was finalized, Cambior undertook an extensive drilling campaign beginning in 1993 which continued uninterrupted through 1995. A core drilling program was initiated by Chesapeake in December 2007 with the initial purpose of twinning numerous Cambior drillholes in both the sediment and intrusive hosted mineralization so as to validate the results of the Cambior holes and provide additional information on the sample preparation, analytical procedures, and assays. Subsequent holes were also completed as infill holes between the two mineralized zones that were untested by Cambior, as well as some step-out holes targeting possible extensions outside the known mineralization. The program also provided drill core for a comprehensive metallurgical test program. A total of 36 holes were drilled in this program for a total of 14,379 m.

In February 2011, Chesapeake undertook a second core drilling program which included 53 holes totaling 23,486 m. The purposes of the core drilling program were to infill between widely spaced holes for conversion of inferred mineral resources to indicated mineral resources, to drill geotechnical holes in support of pit slope stability investigations, and to expand the overall mineral resource with step-out holes. A rotary reverse circulation (RC) drilling program was conducted in 2012 to drill condemnation holes in and around the area of the proposed waste rock management and tailing storage facility, as well as the main Metates plant site. Some of these holes were converted to groundwater piezometer holes. RC drilling totaled 4,200 m in 27 holes.

Five holes, totaling 2,018 m, were drilled for the 2013 campaign at Metates mostly to supply additional metallurgical samples. In 2021, another set of PQ-sized (85 mm) holes were drilled to supply metallurgical samples for column oxidation and leach testing. A summary of drilling used for the estimation of mineral resources at Metates is provided as Table 1-2.

Table 1-2: Summary of Drilling by Campaign

Company	Year	No. of Holes	Meters
Cambior	1993	14	4,827
	1994	92	33,499
	1995	34	10,499
	Subtotal	140	48,825
Chesapeake	2007–2008	36	14,379
	2011	53	23,486
	2013	5	2,018
	2021*	5	2,333
	Subtotal	99	42,216
Total		239	91,041

*Not used for mineral resource.

1.5.2 Sample Preparation, Security and Verification

The Chesapeake sample preparation procedures and security protocols employed were similar to those procedures described for the Cambior 1994–95 programs and would be considered industry standard. Drill core was transported from the drill rig to the secure logging and storage facility at the end of each twelve-hour drill shift. After the core was logged for geology and geotechnical attributes, the core was marked into 3-m sample intervals. The core was photographed and then sawed in half, and one-half placed in a plastic sample bag marked with a unique sample number and sent off for assay.

Specifically for the Chesapeake samples and the 2007-2008, 2011 and 2013 drill campaigns, one of the one-half core assay samples was cut in half to generate what is called a “¼ core duplicate” sample at the rate of about every 40th sample. This ¼ core duplicate sample was assigned a unique sample number. Standards and blanks were introduced into the sample stream with unique sample numbers assigned at the rate of about 1 in 20 samples. The standards used are certified reference material sourced from an independent commercial third party. Three different analytical standards were used, and cover a range of gold and silver values, along with one blank standard to examine carryover contamination from sample to sample.

The Chesapeake samples were shipped in a covered and secured truck to ALS Chemex Laboratories in Hermosillo or Zacatecas, Mexico. Once at the lab, the samples were dried, and the entire sample crushed to 90% passing -10 mesh. Samples were then split, and a 1,000-g subsample obtained, which was then pulverized to 85% passing -200 mesh in a ring and puck type mill. At the rate of about every 40th sample, a second 1,000-g split of the -10 mesh material was obtained and then pulverized to generate a “preparation duplicate” sample which was also assigned a unique sample number. Also at the rate of every 40th sample, the 1,000-g pulverized sample was split in two 500-g subsamples to create “pulp duplicates,” each of which was again assigned a unique sample number. Thus, four separate assays were reported for every 40th sample. These four different assays, performed on four different assay pulps, are instructive in determining the amount of sample variance related to each of these steps: core sample, preparation, and pulverization. After pulverization, a portion of each of the individual pulp samples was shipped to the ALS Chemex Laboratories facility in Vancouver, BC, Canada, where the samples were analyzed. The assays were then reported to Chesapeake both electronically and by signed assay certificates.

The sample preparation and analytical procedures employed by Cambior and Chesapeake are adequate for the purpose of defining mineral resources. Some of the independent reviewers of the Cambior QA/QC procedures identified an assay bias in the 1994 data. The Chesapeake QA/QC work has verified the bias and quantified the likely impact. Cambior’s 1993 and 1994 gold assays have been factored by 0.8985 to correct for an apparent analytical bias at the Bondar-Clegg laboratory.

Independent Mining Consultants (IMC) conducted much of the work to assemble the Cambior drilling database for the Cambior 1997 preliminary feasibility study and still has the original database in its archives. IMC compared this archive data with the assay database provided by Chesapeake at the start of the 2009 mineral resource modeling work. The comparison validates that the original data has not been tampered with nor otherwise altered since the Cambior study. IMC also compared the Chesapeake assays in the database with the ALS Chemex assay certificates to verify the 2007-2008 drilling data. For 2011 drilling, IMC compared the database entries with assay certificates for five holes, about 10% of the new data. No errors were encountered, and IMC accepted the data with no adjustments. Similarly, the assay results for the 2013 drilling was compared and accepted by IMC.

The five holes drilled for the 2013 program were composited to 15 m bench composites and compared with the 2012 mineral resource model. On a hole-by-hole basis, the comparisons are quite variable, but the five holes as a group compared reasonably well and serve to validate the current mineral resource model for gold, silver, and zinc. This further implies that the holes compare reasonably well with the 2011 drilling data. The QA/QC results from the

Chesapeake drilling programs determined there was no problem with the integrity of the assays received from ALS Chemex and all the assays were entered into the database.

1.6 MINERAL PROCESSING AND METALLURGICAL TESTING

In this report, the term “ore” is used to distinguish “whole ore” from flotation concentrates, only for the sake of clarity. It is not meant to indicate economic viability of the material to mining and processing.

Gold and silver in the Metates deposit are refractory due to encapsulation by sulphides, namely pyrite, arsenian pyrite and arsenopyrite. Various oxidation schemes have been tested in the past, including bacterial oxidation, roasting, oxidation under ambient conditions and pressure oxidation (POX) of sulphide concentrates (Austin et. al, 2016). The results show that gold and silver recoveries by cyanidation improve linearly with the degree of oxidation.

While pressure oxidation resulted in high metal recoveries, the initial capital required to build a flotation plant and POX plant is quite high. This study explores the applicability of a two-stage heap leaching process, where material is oxidized first on an on-off pad and then cyanide leached on a dedicated pad.

Early in 2021, Chesapeake Gold completed five diamond drill holes to collect PQ-sized core samples for metallurgical testing. Kemetco Research Inc. in Richmond, British Columbia has been contracted to perform a comprehensive column leach testing program on composites and variability samples towards a preliminary feasibility-level study.

The testing has started with bench-top agitated oxidation and leach tests on intrusive and sedimentary composites that were assembled 7 years ago for previous studies. A few of these tests have been completed, and the results are presented in this report.

1.6.1 Comminution Indices

Comminution parameters were determined during prior studies for the intrusive and sedimentary material samples with results shown in Table 1-3.

Table 1-3: Measured Comminution Parameters for Metates Composites (by Hazen).

Comminution Parameter	Composite	
	Intrusive	Sedimentary
CW _i , kWh/t	13.2	15.7
RW _i , kWh/t	16.7	16.4
BW _i (100 mesh), kWh/t	13.3	12.3
Abrasion Index, A _i , grams	0.052	0.041

1.6.2 Leach Test on Non-Oxidized Samples

About half of the gold and three fifths of the silver in the Metates material is refractory to cyanide leaching. Table 1-4 below shows the average recovery of gold and silver from intrusive and sedimentary composites, as well as from flotation concentrates. The table shows the low gold and silver recoveries of untreated (unoxidized) composites or flotation concentrate. The significant improvement of gold recovery in the carbon-in-leach tests also indicates potential preg-borrowing in the sedimentary material.

Table 1-4: Bottle Roll and Agitation Leach Tests on “Whole Ore” Samples and Rougher Flotation Concentrates

Bottle Roll Leach Tests, “Whole Ore,” P₈₀ = 100 microns, 96 hours				
<i>Direct Cyanidation - 96 hours</i>	Intrusive		Sedimentary	
	Au	Ag	Au	Ag
Extraction %	52.7	28.5	9.0	32.6
Residue g/t	0.41	8.28	0.62	19.32
Calc. Head g/t	0.86	11.58	0.68	28.66
<i>Carbon-In-Leach (CIL) - 96 hours</i>	Intrusive		Sedimentary	
	Au	Ag	Au	Ag
Extraction %	47.6	25.1	49.0	39.7
Residue g/t	0.49	11.61	0.37	15.38
Calc. Head g/t	0.93	15.49	0.73	25.52

Agitation CIL Tests, Rougher Flotation Concentrate, P₈₀ = 212 microns, 48 hours				
<i>Carbon-In-Leach - 48 hours</i>	Intrusive		Sedimentary	
	Au	Ag	Au	Ag
Extraction %	57.3	43.6	37.3	39.7
Residue g/t	2.06	23.83	3.36	110.74
Calc. Head g/t	4.82	42.24	5.36	183.68

The insoluble gold and silver are believed to be encapsulated in pyrite, arsenian pyrite and arsenopyrite. The sulphide needs to be oxidized to liberate the encapsulated values to achieve economic recoveries.

1.6.3 Current Metallurgical Testing

A comprehensive testing program has been developed to determine the operating parameters for the planned heap leach operations at Metates. This includes baseline agitated leach and column leach tests to establish the baseline recoveries of gold and silver from intrusive, intrusive breccia, and sedimentary sample composites. Baseline agitated oxidation tests on ground materials are also included to establish the amenability of the materials to oxidation. A series of column leach tests will be performed on intrusive, intrusive breccia, and sedimentary composites to determine oxidation chemical conditions, oxidation times and crush size.

1.6.4 Agitated Oxidation and Leach Tests

The same intrusive composite sample as in the previous studies were used as the initial sample to determine the amenability of “whole ore” to oxidation in an agitated alkaline system with aeration. The intrusive composite was ground to 80% finer than (P₈₀) 74 microns, and oxidized in an aerated and agitated vessel. The samples were then leached in cyanide in agitated and aerated vessels. The results of the bench-top tests are shown in Table 1-5.

The cyanide soluble gold and silver in the intrusive composite are in line with previous observations from “whole-ore” and concentrates. After oxidation to 47%, Au and Ag recoveries increased to 83% and 82%, respectively. These quick tests indicate that intrusive samples can be oxidized in alkaline environment under atmospheric conditions.

Table 1-5: Baseline Leach Testing of Intrusive Composite Materials

Agitated Leach Tests, "Whole Ore", P ₈₀ = 74 microns, 48 hours						
Sulphide Sulphur Oxidation, %	Unoxidized		18.4%		46.8%	
	Au	Ag	Au	Ag	Au	Ag
Extraction %	64.6	48.5	53.5	68.1	82.8	82.2
Residue g/t	0.31	6.97	0.45	2.85	0.15	1.84
Head g/t	0.87	13.4	0.87	13.4	0.87	13.4

1.6.5 Column Oxidation and Leach Sighter Tests

Column oxidation and leach tests are being conducted in 6-inch diameter by 8-foot columns made of polycarbonate plastic. During the oxidation phase, alkaline solution is introduced at the top of the column at a rate of about 1 liter per day. Air is injected at the bottom of the column to provide oxygen to the oxidation reaction. The composite being tested was crushed to a nominal size of P₈₀ = 13 mm.

Figure 1-2 below are four pictures of the intrusive column from the May 18, 2021 (start of the test) to August 11, 2021. The series of pictures shows how the composite changed in color over time from gray to yellow-brown as it is being oxidized.



Figure 1-2: Column of Intrusive Composite Sample Under Oxidation

The degree of oxidation is being monitored by the total sulphur collected in the solutions every day. Correction was made for the initial sulfate content of the composite that reported with the sulphur going into solution due to oxidation.

1.6.6 Metallurgical Testing Plan for Prefeasibility Study

The focus of the testing program is intrusive material followed by intrusive breccia material, both obtained from the 2021 PQ core drilling. Sedimentary materials, which are not currently in scope of this study, will also be subjected to a limited number of tests to establish possible metallurgical responses.

Baseline tests will include agitated oxidation and leach tests on ground composites (74 microns) and column leach tests on unoxidized composites at ½-inch (-13 mm) crush.

A series of column leach tests will comprise the main body of the test work. Column oxidation tests will be conducted using a range of oxidation times from 60 days to 180 days at ½-inch crush. These tests aim to establish oxidation kinetics for each material type. Column oxidation tests will also be conducted at 1-inch crush at a chosen oxidation time to determine the effect of crush size. After oxidation, all columns will then be subjected to standard column leach test using cyanide solution.

1.6.7 Gold and Silver Recoveries

Based on previous metallurgical testing and current baseline testing, Chesapeake is targeting recoveries of 70% Au and 75% Ag for massive intrusive and intrusive breccia materials. To attain these recoveries, the estimated degree of sulphide sulphur oxidation would need to range from 30 to 50%, depending on sulphide sulphur content and mineralogy of the materials.

1.7 MINERAL RESOURCE

Table 1-6 presents the mineral resource estimate for the Metates Project. Measured and indicated mineral resource amounts to 1.30 billion tonnes at 0.47 grams per tonne (g/t) gold and 12.9 g/t silver for 19.8 million troy ounces (Moz) of contained gold and 542.0 Moz of contained silver. Inferred mineral resource is an additional 62.2 million tonnes (Mt) at 0.32 g/t gold and 9.0 g/t silver for 640,000 ounces contained gold and 18.0 Moz of contained silver.

The mineral resource is broadly divided into mineral resources that are intrusive hosted and mineral resources that are sediment hosted. In terms of measured and indicated mineral resource tonnes, about 80% of the mineral resources are sediment hosted and 20% intrusive hosted. Due to higher gold grade, the intrusive hosted mineral resources account for 27% of the contained gold ounces.

The mineral resources are based on a block model developed by IMC during July 2014. The results from the 2021 PQ core drilling have not yet been included in an updated mineral resource.

The measured, indicated, and inferred mineral resources reported herein are contained within a floating cone pit shell and are compliant with the “reasonable prospects for economic extraction” clauses of the Canadian NI 43-101 regulations. The mineral resource cone shell is based on a gold price of US\$1600 per ounce and a silver price of US\$20 per ounce.

The mineral resources are based on an equivalent gold cut-off grade of 0.26 g/t where:

$$\text{Gold Equivalent} = \text{Gold} + \text{Silver} / 74.67$$

The gold equivalent calculation accounts for all the relevant price and recovery parameters. Measured, indicated, and inferred mineral resources were allowed to contribute to the economics for the mineral resource cone shell.

Table 1-6: Mineral Resource

Resource Category	Mtonnes	Gold Eq. (g/t)	Gold (g/t)	Silver (g/t)	Gold (moz)	Silver (moz)
Measured Mineral Resource	395.4	0.79	0.59	15.5	7.44	197.3
Intrusive Host	103.1	0.98	0.76	16.5	2.52	54.6
Sediment Host	292.4	0.73	0.52	15.2	4.92	142.7
Indicated Mineral Resource	907.0	0.58	0.42	11.8	12.36	344.7
Intrusive Host	146.0	0.76	0.60	11.9	2.79	55.9
Sediment Host	761.1	0.55	0.39	11.8	9.57	288.7
Measured/Indicated Resource	1,302.4	0.65	0.47	12.9	19.80	542.0
Intrusive Host	249.0	0.85	0.66	13.8	5.32	110.6
Sediment Host	1,053.4	0.60	0.43	12.7	14.48	431.4
Inferred Mineral Resource	62.2	0.44	0.32	9.0	0.64	18.0
Intrusive Host	3.4	0.51	0.43	6.0	0.05	0.7
Sediment Host	58.8	0.44	0.32	9.2	0.60	17.3

Notes:

1. The Mineral Resources have an effective date of 18 May 2021 and the estimate was prepared using the definitions in CIM Definition Standards (10 May 2014).
2. All figures are rounded to reflect the relative accuracy of the estimate and therefore numbers may not appear to add precisely.
3. Mineral Resources that are not Mineral Reserves do not have demonstrated economic viability.
4. Mineral Resources are based on prices of US\$ 1600/oz gold and US\$ 20/oz silver.
5. Mineral Resources are based on a gold equivalent cut-off grade of 0.26 g/t.
6. The gold equivalent value is calculated as follows:

$$\text{Gold Equivalent (g/t)} = \text{Gold (g/t)} + \text{Silver (g/t)} / 74.67$$
 based on gold recovery of 70% and silver recovery of 75%.
7. Table 14-2 accompanies this Mineral Resource statement and shows all relevant parameters.
8. Mineral Resources are reported in relation to a conceptual constraining pit shell in order to demonstrate reasonable prospects for eventual economic extraction, as required by the definition of Mineral Resource in NI 43-101; mineralization lying outside of the pit shell is excluded from the Mineral Resource.

1.8 MINING METHODS

The Metates mine will be a conventional open pit mine. Mine operations will consist of drilling holes with medium diameter (approximately 20.3 cm) blast holes, blasting with emulsions and ANFO (ammonium nitrate/fuel oil) depending on water conditions, and loading plant feed into large off-road trucks with hydraulic shovels and wheel loaders. Plant feed will be delivered to the primary crusher and waste to various waste storage facilities. The Metates mineral resource is broadly divided into two types: intrusive-hosted and sedimentary-hosted. The mine plan for this study only considered the intrusive-hosted mineralization as potential plant feed. There will be a stockpile for sedimentary-hosted resource that is not considered plant feed for this study. There will also be a low-grade stockpile facility to store marginal grade intrusive material for processing at the end of commercial pit operations. There will be a fleet of track dozers, rubber-tired dozers, motor graders, and water trucks to maintain the working areas of the pit, waste storage areas, and haul roads.

A mine plan was developed to supply plant feed to a crushing plant with the capacity to process 15,000 tpd (5,475 ktpy). After crushing, the material is placed on a pad to allow it to oxidize after which it is transferred to a permanent pad for cyanide leaching. The mine is scheduled to operate two 12-hour shifts per day for 365 days per year.

Based on the mining plan developed for this study, the commercial life of the project is 31 years after a brief preproduction period. Total mineral resource processed is 166.1 Mt at 0.756 g/t gold and 15.71 g/t silver. This amounts to 4.04 Moz of contained gold and 83.9 Moz of contained silver. Only measured and indicated mineral resource is considered for this study. Inferred intrusive mineral resource in the pit is only half a million tonnes and is treated as waste. However, this PEA is preliminary in nature and there is no guarantee that the results of this study will be realized or that the mineral resources will be converted to mineral reserves.

Figure 1-3 shows the final pit and the various waste storage areas and stockpiles. These include the following:

- The sediment resource stockpile, north of the pit, contains of 207.4 Mt at 0.40 g/t gold and 18.4 g/t silver. This is 2.65 Moz of contained gold and 122.6 Moz of contained silver. As discussed above, this material is not processed for this current study.
- The NAG (non-acid generating) waste storage area east of the pit contains 42.9 Mt. This facility contains the post mineral volcanic rocks.
- The PAG (potentially acid generating) waste storage area northwest of the pit contains 117.6 Mt. This is composed of mine waste in intrusive and sedimentary rock, other than the sedimentary resource stockpile which would also be considered as PAG.
- The low-grade stockpile, north of the sedimentary resource stockpile, contains 38.9 Mt at 0.37 g/t gold and 15.0 g/t silver. This is 466,100 ounces of contained gold and 18.7 Moz of contained silver. This material is low grade intrusive hosted mineralization. This material is processed at the end of open pit operations.

The PAG and NAG waste storage areas, and the sedimentary resource stockpile, are developed in 30-m lifts at angle of repose (37°). There is a 35 m setback between lifts so the overall slope angle is 2.5H:1V, about 22°. It is anticipated that this is flat enough to make closure easier. The low-grade stockpile is at its angle of repose as it is not anticipated that it will be a permanent facility.

**METATES SULPHIDE HEAP LEACH PROJECT - PHASE 1
FORM 43-101F1 TECHNICAL REPORT**

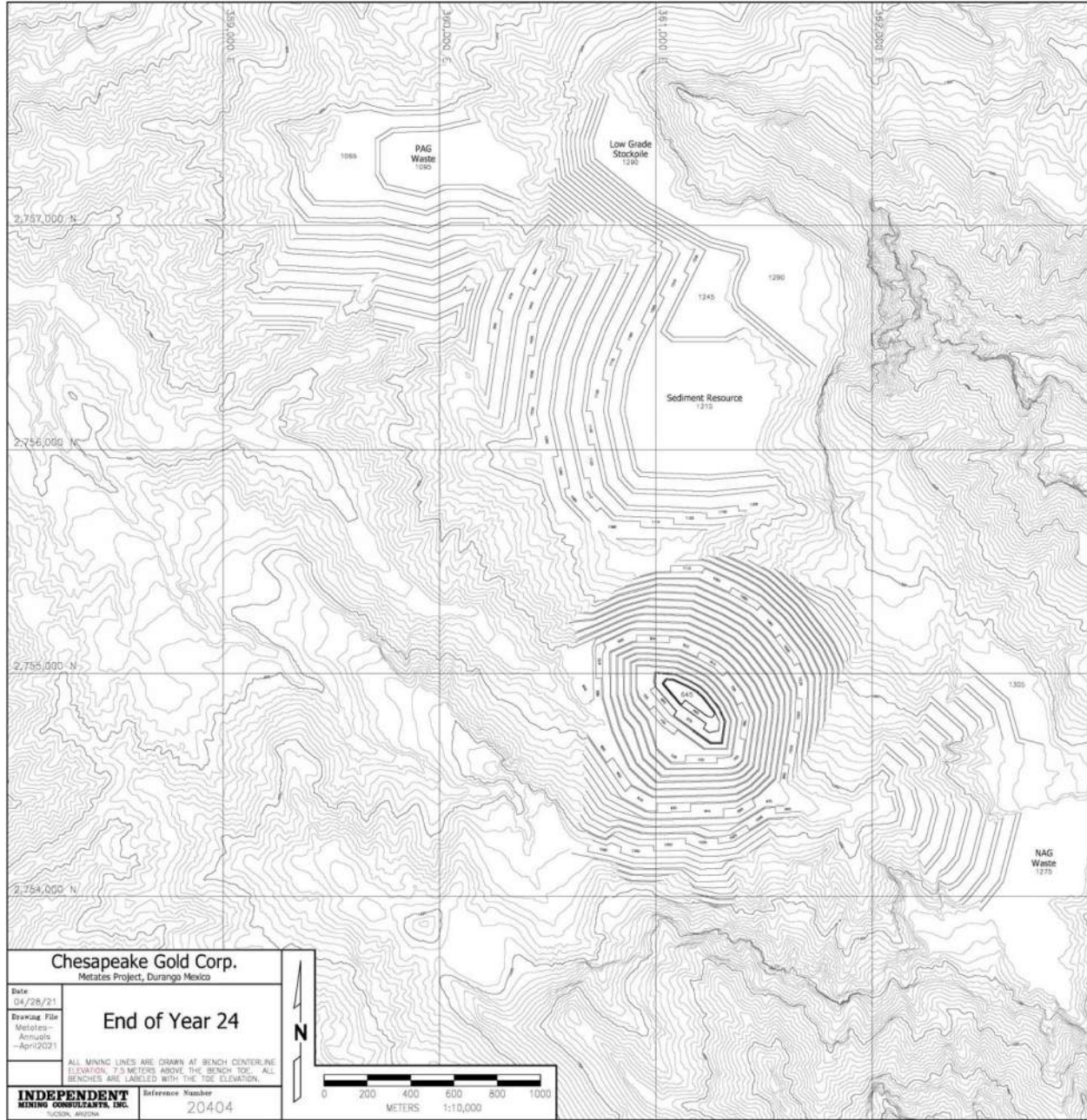

Figure 1-3: Waste Storage Areas and Stockpiles, IMC 2021

1.9 RECOVERY METHODS

The planned Metates heap leach operation has a nominal capacity of 15,000 tpd at an overall availability of 90%.

The overall processing scheme would be to crush the material to a P_{80} of 13 mm, oxidize it on an on-off pad, and leach it with cyanide on a dedicated pad. A simplified flow sheet of the Metates process is shown in Figure 1-4. The overall site layout is shown in Figure 1-5.

1.9.1 Oxidation Pad Operations

1.9.1.1 Crushing

The Metates crushing plant will comprise three stages of crushing, starting with a jaw crusher set at 130 mm (5 inches) for primary crushing, followed by a standard cone crusher for secondary crushing (closed side set at 30 mm), and finally a short-head cone crusher for tertiary crushing (closed side set at 20 mm). Particle sizes are controlled by double decked screens before the secondary crusher and before the tertiary crusher. The target P_{80} of the final product is 13 mm.

The crushed material will be fed to a rotating-drum mixer, where alkaline solution will be added to thoroughly mix into the crushed material. From here, the material will be transferred to the oxidation pad through a series of overland and grasshopper conveyors and a stacker.

1.9.1.2 Oxidation On-Off Pad

Oxidation of the mined and crushed material will be conducted on an on-off pad, as shown in Figure 1-5. It is 438 m wide and 961 m long, with a total useable area of 31.4 hectares. The pad is lined with HDPE and a 1-m layer of permeable aggregate as liner cover.

The oxidation pad will be divided into 13 cells along the length of the pad and separated with curbs that are built into the HDPE liner. One of the cells is always empty to serve as a buffer between the cell that is being stacked and the cell that is being emptied. Materials in each cell will spend from 90 to 180 days of the oxidation cycle, which will be described in more detail below.

Oxidation of sulphide sulphur contained in the material is achieved in a moist alkaline environment with oxygen as the ultimate source of oxidation potential. Air will be continuously replenished by active injection of air at the bottom of the oxidation heap. Alkali will also be replenished continuously or intermittently by irrigating alkaline solution at the top of the heap at rates mainly dictated by pH of the solution that drains out at the solution collection point and limited by the holding capacity of the material while maintaining heap permeability to air.

Sampling lysimeters will be installed in the oxidation heap to monitor oxygen level, pH, dissolved sulphur concentrations and possibly other parameters and evaluate the progress of the oxidation process.

The oxidation process may take from 90 to 180 days, depending on the material type being oxidized. Projections on oxidation times will be derived from testing of composites and variability samples and will be further refined from measurements during operations. When the target oxidation is achieved, the material will be rinsed with raw water, allowed to drain, and transferred to the dedicated leach pad for cyanide heap leaching.

METATES SULPHIDE HEAP LEACH PROJECT - PHASE 1
FORM 43-101F1 TECHNICAL REPORT

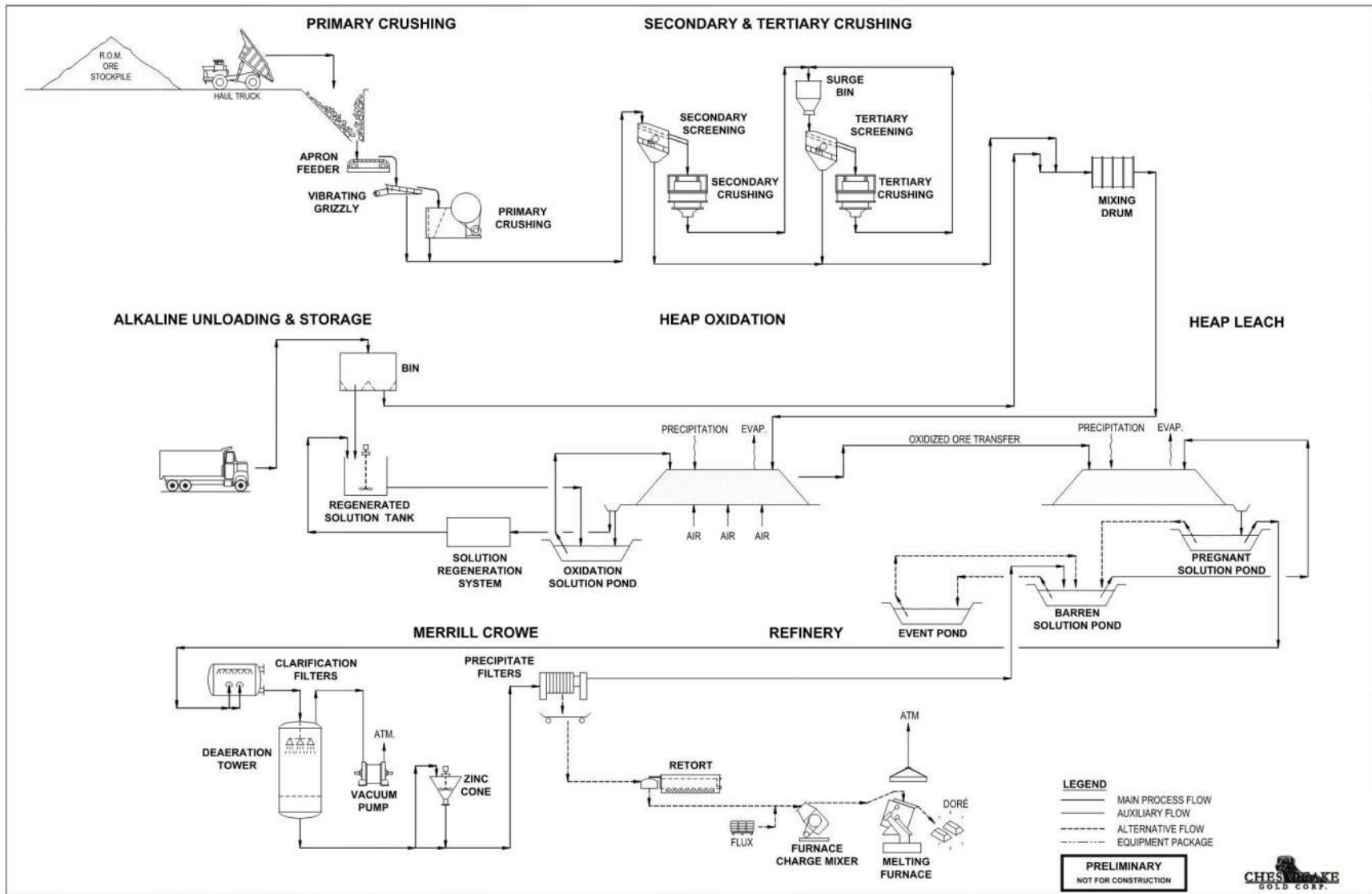

Figure 1-4: Simplified Flow Sheet of the Metates Sulphide Heap Leach Project

1.9.1.3 Solution Regeneration

The pH of the oxidation solutions coming from each cell will be monitored. Once the pH falls below a threshold pH, for example pH 9.5, solution from that cell will be diverted to the solution regeneration system. The rest of the solution (with pH above the threshold) will be recycled to the top of the oxidation stacks through the oxidation solution pond.

The process of regenerating oxidation solutions is currently proprietary. The process neutralizes the acid produced during oxidation, thereby restoring the pH to 10.5 to 11.

1.9.2 Cyanide Heap Leaching and Merrill-Crowe Plant

Cyanide heap leaching of oxidized material will be conducted on a dedicated leach pad, which is currently designed as a valley-fill facility as shown in Figure 1-5. Oxidized material would be transferred from the oxidation pad to the dedicated heap leach pad by a system of overland conveyors, portable conveyors, and a radial stacker. The planned lift height is 20 feet, but the stacker would stack up to 25 feet to allow for slump from the material's own weight.

The planned irrigation rate will be 10 liters per hour per cubic meter (L/h/m²) for up to 60 days of primary leach. Cyanide concentration will be from 1 to 1.5 kg/tonne of solution. Pregnant solution will collect at the bottom of the heap and flow by gravity to the pregnant solution pond, from where it will be pumped to the Merrill-Crowe plant.

A standard Merrill-Crowe zinc cementation plant is included in the design to recover gold and silver from the pregnant leach solution. The plant has a design capacity of 680 cubic meters per hour (m³/h) (3,000 gallons per minute [gpm]) of pregnant solution. Gold and silver precipitates will be filtered then dried in a retort to remove moisture and mercury. The filtered precipitates are finally smelted into doré bullions in a natural gas-fired melting furnace.

1.9.3 Reagents, Water and Power Consumption

The main reagents for the process are lime, soda ash and cyanide for the oxidation and leach stages; zinc dust, lead nitrate, diatomaceous earth and smelting fluxes for Merrill-Crowe and refinery; and antiscalant and flocculant where required. Consumption rates for the reagents are presented in Section 13.

The Metates process plant is projected to require 74 m³/h of raw water makeup to sustain the operation. In addition, an estimated 20 m³/h of raw water for mine dust control and 1.25 m³/h for potable water are allocated, for a total consumption of 95 m³/h.

The total connected power load is 11,691 kilowatts (kW), of which 7,742 kW is drawn in a typical year. This translates to about 11 kWh/tonne of material processed or US\$ 1.11/tonne in power cost. Details of the power consumption are discussed in Section 18.

1.10 PROJECT INFRASTRUCTURE

1.10.1 Site Layouts

The general arrangement and basic operational components for the Metates site including the open pit, oxidation heap, heap leach pad, process facilities and waste dumps are shown on Figure 1-5.

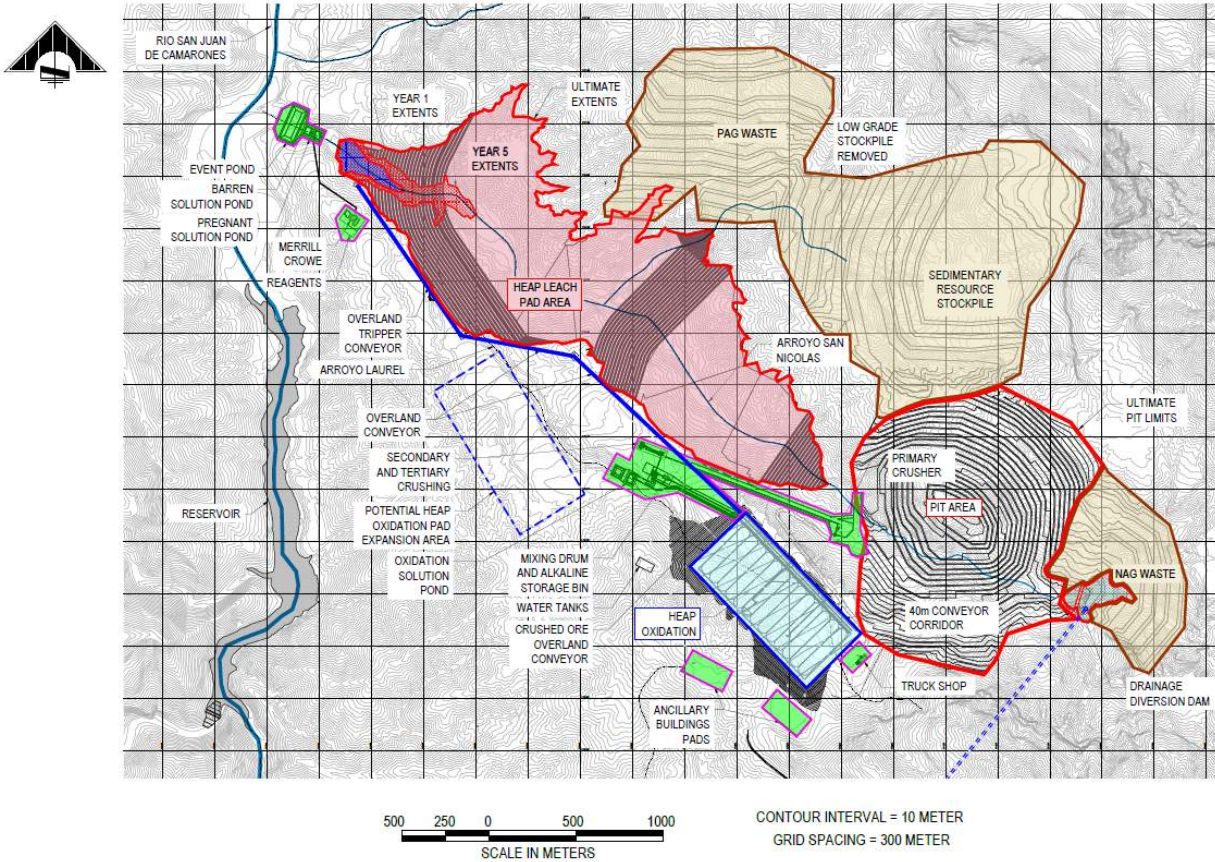

Figure 1-5: General Arrangement of Open Pit, Stockpile and Waste Rock Dumps and Process Facilities

1.10.2 Access Roads

Existing road access to the Metates sites is from the city of Durango, Durango State, via Federal Highway 23 about 170 km to the town of Santiago Papasquiaro, then west on Federal Highway 36 for about 144 km to the village of Ojito de Camellones. From Ojito de Camellones, access to the Metates site is then via about 50 km of unpaved dirt roads of variable quality (total road distance of about 364 km). This same road allows access via a spur road to the village of San Juan de Camarones while the main road extends to other villages in the area including Vascogil and San Miguel el Alto. Travel time from Metates to Santiago Papasquiaro, the closest location for goods and supplies, is about 5 hours with an additional 2 hours to reach Durango City.

This road access will be used for hauling in heavy equipment to the Metates site including haul trucks and shovels, and crushing equipment. As such, the existing bridges, overpasses and unpaved portions of the road will need to be evaluated and upgraded as required to satisfy the requirements for the anticipated use. Design considerations would include weight capacities, design speed of no more than 60 km/hour with a standard maximum grade of 10% with a few sections of steeper grades in switchback conditions, normal minimum curve radius of 120 m with a 20 m minimum radius in switchback conditions, drainage basins, culverts, and at-grade (“vado”) crossings.

Seasonal access to the Metates site from Sinaloa State is also possible during low-water flows in the Rio San Lorenzo and tributaries (typically December to July). Paved road access from the cities of Mazatlán or Culiacán is possible to the town of Cosalá. A series of variably improved dirt roads extend northeast from Cosalá to a crossing on the Rio San Lorenzo where a primitive road then follows the river upstream to the Rio San Juan de Camarones where the road

continues up to the Metates site. This access requires multiple river crossings but is a travel distance of only about 106 km from Cosalá to Metates. The road access between Cosalá and Metates might be locally improved to provide an alternate access route.

1.10.3 Water Supply, Reservoir, and Distribution

One of the most critical elements of the Metates Project is the establishment of an adequate supply of fresh water to support a wide range of operational demands.

Water supply and conveyance at the Metates Project is a combination of surface and groundwater abstraction from different sources. Water must be stored during periods of surplus to be used during times of deficit and geography dictates the locations of these storage facilities without regard to project convenience.

The main fresh water supply reservoir will be constructed by Year -1 in the southwest section of the project area within the main Rio San Juan de Camarones drainage just downstream of the confluence with the Arroyo Camarones. The reservoir will impound water from the Rio San Juan as well as water collected by the Mine pit diversion dam and diverted to the Arroyo Camarones via the diversion tunnel. The total height of the dam will be approximately 32 m from the downstream toe elevation of 540 m to the crest elevation of 572 m. The downstream and upstream slopes are 2.5H:1V and 2H:1V, respectively. A cut-off trench will be excavated under the upstream toe to allow for the alluvium to be removed (Ausenco, 2015d).

The dam creates a reservoir to provide storage for 4.0 million cubic meters (Mm³) of water by Year -1 including 0.5 Mm³ of dead-load storage for sediment build up. To maintain a 3.5 Mm³ storage capacity year-round, yearly maintenance removal of stream sediments will be required as needed during the dry season.

The reservoir level and the water available will fluctuate, dropping down in dry seasons and increasing in wet seasons with anticipated non-contact water spillway overflows through most of the wet season months. Water in the reservoir will be pumped to the plant area for use in operations, primarily as fresh water supply.

1.10.4 Power Supply and Distribution

Electrical power for the Metates mine will be transmitted along a newly constructed 115 kilovolt (kV) power line that will tie into the existing CFE grid at a substation to be constructed near the Ciénega II substation. The 115 kV line will extend approximately 20 km to the southwest to the Metates site and once complete the line will be turned over to the CFE. Completion of the power supply infrastructure will also require a switching substation with 3 high voltage feeders at the existing power line, and a substation at the Metates site.

1.11 ENVIRONMENTAL STUDIES, PERMITTING AND SOCIAL AND COMMUNITY IMPACTS

Baseline environmental studies were undertaken by Cambior regarding surface water and groundwater, climate, air quality, biological conditions, and archaeology. In addition, numerous samples of mine rock (both resource material and waste) have been studied for their acid generating and acid neutralization potential. This information has been summarized in Sections 18 and 20 of this report. Golder Associates (Golder) of Lakewood, Colorado completed a re-evaluation of the 1997 studies using new samples from the 2008 drilling. The new information from Golder, along with extensive testing and additional lab and on-site testing of waste rocks and process related samples (tailing and neutralization residue), was summarized by Interrallogic, Inc. (ITL) of Golden, Colorado.

At the Metates site, baseline information on both surface and groundwater was collected by Cambior during the period 1994-1997. Schlumberger Water Services (SWS) established new surface water and groundwater sampling locations at Metates that cover the same general area as the older sampling sites and has also resampled the same groundwater wells established during the older period effectively extending the baseline monitoring timeframe. The goal of the

surface and groundwater sampling program is to characterize the pre-mining or pre-operations conditions at the Metates site. This information is required to be included as part of the permitting applications to the Secretaría de Medio Ambiente y Recursos Naturales (SEMARNAT).

Nine groundwater monitoring wells have been installed and are currently sampled regularly at the Metates site. Sampling of the groundwater sites generally involves collection and chemical analysis of groundwater as well as physical determination of groundwater level and other field parameters. Eight surface water sampling sites have been installed at the Metates site, five of which are regularly sampled. Sampling of surface water sites generally involves surface flow measurements as well as the collection and chemical analysis of surface waters and field parameters.

Environmental baseline data collection and reporting has been completed by M3 Mexicana for the Metates mine site. The environmental baseline work included a survey of the climate, geologic hazards, air quality, surface water runoff, vegetation, wildlife, federally designated conservation areas, socio-economic evaluation, and a review of cultural/historic sites. The results of the site visit, record review, and preliminary investigations did not reveal any significant environmental issues. There are expected to be certain at-risk species (Priority 1, 2, and 3) of vegetation and wildlife in the areas examined. Specific management plans will need to be developed to address each of the at-risk species encountered. Additional follow-up/confirmation investigations will be necessary as the specifics of the project are developed.

For the most part, federal laws regulate mining in Mexico, but there are some aspects subject to state or local approval. SEMARNAT is the chief agency regulating environmental matters in Mexico. The Comisión Nacional del Agua (CONAGUA) has authority over matters concerning water rights and activities that affect ground and surface water, including diversion of floodwaters. A permit application will be submitted for the Metates site access/infrastructure corridor created for the site. The main permits required for construction and operation include the Environmental Impact Manifest (MIA), Change of Land Use (CUS), and Risk Analysis (RA), all administered by SEMARNAT, and Water Rights, Explosives, and Cultural Resources, all administered by other federal agencies. Overall, permitting in Mexico is straightforward and governed by mandated processing timeframes. For the Metates Project, a permitting timeframe not exceeding 18 months is considered reasonable, based on current information.

Chesapeake has had extensive and on-going discussions with representatives from the Durango State Government. The state is very supportive of the future development of the Metates Project and has pledged to support Chesapeake in any way they can.

1.12 CAPITAL COST SUMMARY

The capital costs for mining at Metates was developed by IMC. M3 was responsible for developing capital costs for the processing plant, power distribution, site preparation, etc. Chesapeake provided the owner's costs, including the Metates access road, other selected infrastructure, and land acquisition costs.

The consolidated mine and process facility initial capital costs are shown in Table 1-7. The preliminary economic assessment-level total estimate for the mine and process facility is US\$359 million, which includes a contingency of US\$63.5 million.

Table 1-7: Consolidated Mine and Process Facility Initial Capital Costs

	Cost (US\$)
Metates Site	
Mining Equipment & Mine Development	\$18,713
Crushing & Conveying	\$36,104
Ponds & Pads	\$28,404
Reagent/Regeneration System	\$11,677
Merrill-Crowe & Refinery	\$9,124
Subtotal	\$104,022
Infrastructure	
General Site/Earthworks/Access Roads	\$106,069
Electric Power	\$7,851
Water Supply	\$7,380
Ancillaries & Buildings	\$11,121
Subtotal	\$132,421
Freight, Taxes & Duties	\$4,060
Total Direct Field Cost	\$240,503
Indirects-EPCM, Commissioning & Spares	\$32,047
Total On Site Constructed Cost	\$272,550
Contingency	\$63,459
First Fills	\$6,000
Owner's Cost	\$17,200
Total Capital Cost	\$359,209

1.13 OPERATING COST SUMMARY

The operating costs were generated by IMC for all mining activities assuming contract mining. M3 estimated the costs for the processing operations and infrastructure.

Table 1-8 is the consolidated summary of the mine and process related operating costs for the Metates including support facilities. The life of mine operating cost for the Metates Project is estimated to be US\$ 18.29 per tonne of material processed. The equivalent AISC ("all-in sustaining cost") is US\$ 12.72 /tonne or US\$ 748.46/oz Au on a LOM basis when considering by-product credits for silver sales, sustaining costs, and other costs.

Table 1-8: Consolidated Operating Cost Summary

Operating Costs	LOM Average	
	US\$/t processed	US\$/Oz Au
Mining (including rehandle)	\$7.51	\$441.70
Processing (Crushing, Stacking, Oxidation, Leach, Merrill-Crowe)	\$8.05	\$473.65
Site Support	\$1.41	\$83.69
Profit Sharing	\$1.32	\$77.74
Total Operating Cost	18.29	\$1,075.78
Royalties (0.5% NSR & 7.5% Gov't EBITDA Royalty)	\$1.45	\$85.35
Doré Treatment Charges	\$0.17	\$10.15
By-Product Silver Credits	(\$8.25)	(\$485.31)
Total Cash Cost	\$11.66	\$685.97
Sustaining Capital, Reclamation & Closure	\$1.06	\$62.49
All-In Sustaining Cost (AISC)	\$12.72	\$748.46

1.14 ECONOMIC ANALYSIS

The Metates Project economics were performed using a discounted cash flow approach, presenting the Net Present Value (NPV), Payback Period (time in years to recapture the initial capital investment) and the Internal Rate of Return (IRR). Annual cash flow projections were estimated over the life of the mine based on estimates of capital expenditures, production cost, and sale revenue.

Only measured and indicated mineral resource is considered for this study. Inferred intrusive mineral resource in the pit is only half a million tonnes and is treated as waste. The results of this PEA are preliminary in nature. There is no certainty that the results of this PEA will be realized. Mineral resources that are not mineral reserves do not have demonstrated economic viability.

The financial results were developed for three different metal price assumptions, namely base case, low case, and high case (spot price); these assumptions were provided to M3 by Chesapeake. The financial results are presented in Table 1-9.

The financial parameters for the leveraged case were calculated assuming that 60% of the initial capital is debt financed at an annual interest rate of 7%, an upfront financing fee of 3%, and a seven-year term post commencement of commercial production with a balloon payment of 30% of the principal at maturity.

Table 1-9: Financial Results Summary

Metal Price Assumptions	Low Case	Base Case	High (Spot)
Gold Price (US\$ per troy ounce)	\$1,360	\$1,600	\$1,786
Silver Price (US\$ per troy ounce)	\$19	\$22	\$26
USD:CDN Exchange Rate	1:1.25		
USD:MEX Exchange Rate	1:20.05		
Unlevered Pre-Tax Economic Indicators			
NPV at 5% Million C\$	\$896	\$1,427	\$1,906
NPV at 5% Million US\$	\$717	\$1,142	\$1,525
IRR %	25.3	35.4	45.2
Payback, years	3.4	2.5	2.0
Unlevered After-Tax Economic Indicators			
NPV at 5% Million C\$	\$513	\$857	\$1,167
NPV at 5% Million US\$	\$410	\$685	\$933
IRR %	17.9	24.6	30.9
Payback, years	5.2	3.7	2.9
Leveraged After-Tax Economic Indicators			
NPV at 5% Million C\$	\$509	\$852	\$1,162
NPV at 5% Million US\$	\$407	\$682	\$930
IRR %	26.9	41.2	55.9
Payback, years	3.4	2.2	1.6

A sensitivity analysis was performed for the project using metal prices, operating cost, capital cost and metal recovery, on a pre-tax basis using the unlevered cash-flow model. The economic indicators tested against these factors are the NPV and IRR. The results of the analysis are shown in Figure 1-6 and Figure 1-7.

The recovery and the metal price factors have the greatest impact on the economic indicators. Initial capital cost has a low impact on NPV but has a greater impact on IRR.

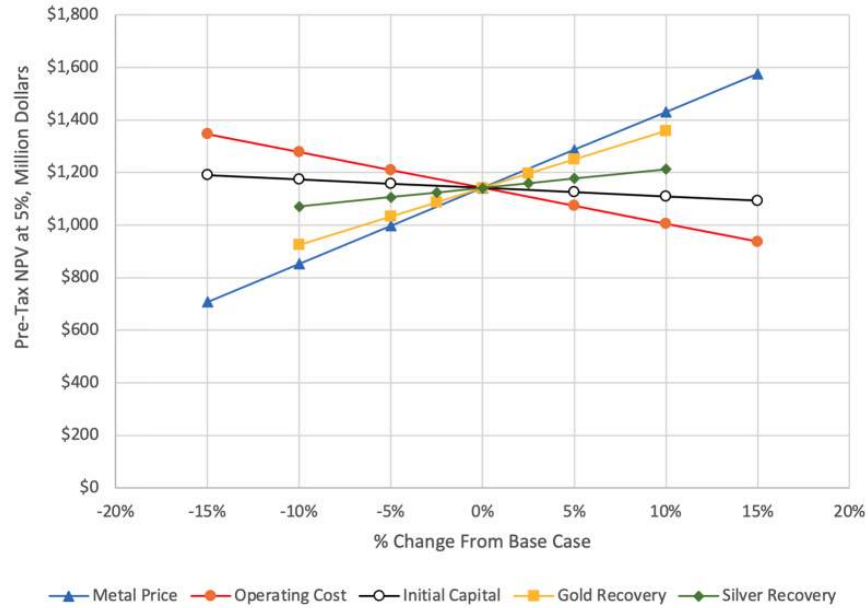

Figure 1-6: Sensitivity of Pre-Tax NPV @ 5% to Metal Prices, Operating Cost, Capital Cost and Recovery

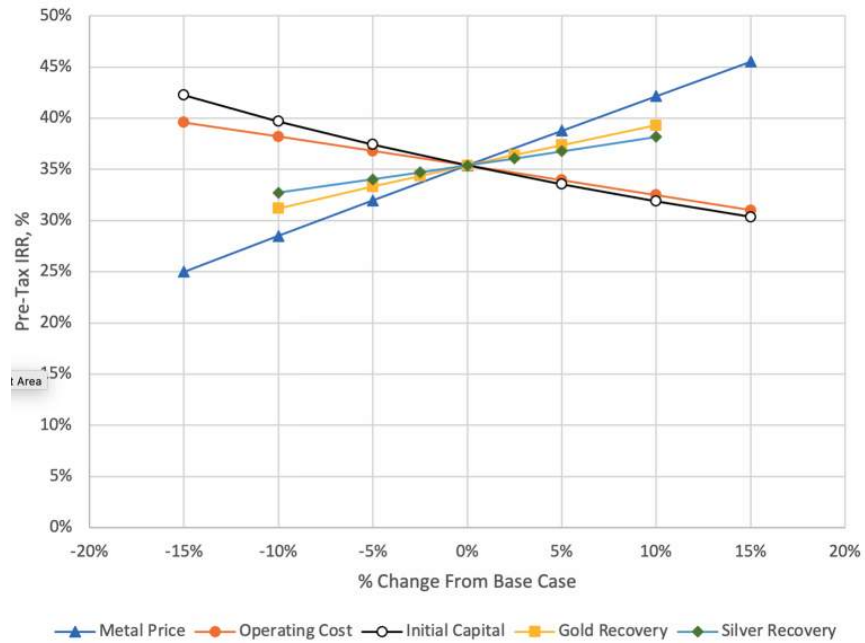

Figure 1-7: Sensitivity of Pre-Tax IRR to Metal Prices, Operating Cost, Capital Cost and Recovery

1.15 CONCLUSIONS AND RECOMMENDATIONS

1.15.1 Conclusions

Metates is an undeveloped world-class mineral deposit with minimal obstacles in the way of becoming a producing mine. Few deposits of this scale have development options with capital costs on the order of \$359 million, while carrying a pre-tax NPV of over US\$1 billion. Compared to the two previous PFS studies, this PEA has substantially lower initial capital, lower project execution risk and stronger financial indicators. The short payback period and early positive cash flow allow for flexibility in Metates future development, including the potential to capitalize on the low grade and sedimentary hosted mineralization and further exploration of the limits of the mineralization. It is recommended by M3 that Chesapeake advance the Metates Project toward the completion of an NI 43-101-compliant pre-feasibility study once conclusive results from the metallurgical testing program are available.

1.15.2 Recommendations

M3 recommends that Chesapeake advance the Metates Project toward the completion of a pre-feasibility study once results are available from the ongoing metallurgical testing program. The preferred process option is heap oxidation of crushed mineralized material, followed by cyanide extraction on a dedicated heap leach pad, with gold and silver recovered as doré completed through a Merrill-Crowe plant.

When the project is advanced to a pre-feasibility study, IMC recommends the resource block model be updated to incorporate the results of the five holes drilled during 2021. This would include updating the geologic interpretation, the grade estimates, and the mineral resource classification. Consideration will be given to an infill drill program focusing on the intrusive-hosted mineralization based on the higher than modeled grades noted in the recent core drilling program.

Current testing will determine oxidation kinetics, reagent consumption and metal recoveries for the planned prefeasibility study. Optimum conditions for economic recovery of gold and silver should be determined from the results for these tests. Testing is also planned to determine the variability of operating parameters and projected recoveries using a range of ore types and grades. M3 recommends that these plans be implemented towards a prefeasibility study.

If additional drilling information and/or core is required for various needs going forward, M3 recommends that drilling be performed in the area of planned material extraction for Years 1 – 5 in the current mine plan to increase confidence in the grades that will be processed early in the mine life.

The sedimentary material, mentioned throughout the report as a stockpiled material, holds potential as economically viable material if metallurgical processes are designed to realize its potential. Methods using autoclaves, CIL or RIL have been studied in the past and shown to be effective in improving the recovery of gold and silver from the sedimentary mineralization. While this potentially preg-borrowing material may not be suitable for conventional cyanide heap leach recovery, testwork is planned to further investigate possible treatment scenarios to realize its potential. Over the 31-year span of this processing plan, one of these treatment scenarios may provide a path for the sedimentary material to be reclaimed and processed. This is the driver for separating the mineralized sedimentary material stockpile from the other PAG material dump in the current site design plan.

Other recommendations to increase the accuracy of the study and optimize the economics of the project are detailed in Section 26. These include additional geotechnical investigations, optimization of earthworks particularly for the oxidation pad, more accurate vendor quotations, reagent sourcing, and others.

2 INTRODUCTION

Metates is a gold and silver deposit located in northwestern Mexico in Durango State, some 160 km northwest of the city of Durango and 175 km north of the coastal resort city of Mazatlán. Geographic coordinates of the Metates deposit area are 24°55'N latitude and 106°23'W longitude, and the UTM coordinates are 2,755,000N and 360,000E (NAD 83).

The Metates property comprises twelve contiguous concessions, totaling 4,260.7 hectares in area. The measured and indicated mineral resources for this PEA are estimated at 1.30 billion tonnes (Bt) at 0.47 grams per tonne (g/t) gold and 12.9 g/t silver for 19.8 million troy ounces (Moz) of contained gold and 542.0 Moz of contained silver. Inferred mineral resource is an additional 62.2 million tonnes (Mt) at 0.32 g/t gold and 9.0 g/t silver for 640,000 ounces contained gold and 18.0 Moz of contained silver. Metates hosts one of the largest gold and silver deposits in the world.

M3 was commissioned by Chesapeake to prepare a PEA for the Metates Sulphide Heap Leach Project - Phase 1 in Durango, Mexico, using a two-stage heap leaching process.

2.1 PURPOSE OF REPORT

Chesapeake has previously filed NI 43-101-compliant technical reports regarding the Metates Project on the website for the System for Electronic Document Analysis and Retrieval (SEDAR). These include a PEA in June 2010 and April 2011, a preliminary feasibility study (PFS) in March 2013 and an updated PFS in April 2016. The studies were based on a pressure oxidation (POX) process to liberate gold and silver from sulphide concentrates for cyanide leaching. While the project economics were positive, the initial capital cost was high.

Recent developments in the gold industry have shown that ores that are refractory due to sulphide encapsulation may be oxidized in a heap leach setting, thereby liberating enough gold and silver for economic extraction by cyanide heap leaching. This two-stage process would not be as capital-cost intensive as the POX options that were previously studied.

This PEA examines a two-stage heap process to recover gold and silver from sulphide material obtained from intrusive-hosted mineralization of the Metates mineral resource. The first stage would be the oxidation of the material on an aerated on-off pad with continuous neutralization of acid produced. The second stage would be conventional cyanide heap leaching of the oxidized material on a dedicated leach pad. Gold and silver in pregnant solution from the cyanidation heap would be recovered in a Merrill-Crowe process plant.

This PEA includes a revised mineral resource estimate for the Metates Project and replaces the mineral reserve estimate contained in the Company's updated PFS dated April 29, 2016.

This report was prepared by M3 Engineering & Technology Corp. (M3) at the request of Chesapeake. Chesapeake is a Canada-based company trading on the TSX (Venture Exchange) under the symbol CKG and the OTCQX market under the symbol CHPGF. Chesapeake's corporate office is located at:

CHESAPEAKE GOLD CORP.
1512 Yew Street, Suite 201
Vancouver, B.C.
Canada V6K 3E4

2.2 SOURCES OF INFORMATION

New information, updates to, and review of existing information were provided and performed by the Qualified Persons ("QPs") listed in Table 2-1. New site visits were deferred for this study because of travel restrictions in place due to the Covid 19 pandemic.

Table 2-1: List of Qualified Persons, Dates of Site Visits and Areas of Responsibility

QP Name	Company	Qualification	Site Visit Date	Area of Responsibility
Justin M. Black	M3 Engineering & Technology Corporation Tucson, AZ	PE	No Visit	1.2-1.4, 1.10, 1.12- 1.15, 4, 5, 6, 9, 18, 19, 21 (except 21.1.3 and 21.2.3), 22, 23, 24, 25.1, 25.6, 25.7, 25.8, 26.5, and 26.6
Art S. Ibrado	Fort Lowell Consulting PLLC Tucson, AZ	PhD, PE	December 8, 2009	1.1, 1.6, 1.9, 2, 3, 13, 17, 25.4, 25.5, 26.3, 26.4, and 27
Michael G. Hester	Independent Mining Consultants, Tucson, AZ	FAusIMM	April 24, 2009, October 30, 2013	1.5, 1.7, 1.8, 7, 8, 10, 11, 12, 14, 15, 16, 21.1.3, 21.2.3, 25.2, 25.3, 26.1 and 26.2
Richard K. Zimmerman	M3 Engineering & Technology Corporation Tucson, AZ	MSc, RG, SME-RM	No Visit	1.11 and 20

2.3 TERMS OF REFERENCE

This study was conducted using mainly metric units, following the International System of Units (SI) for unit terms and prefixes where possible. Unless otherwise noted, all weights are reported on dry basis. Gold and silver grades are expressed in grams per metric tonne (g/t). All currency is in US\$ as of the 2nd quarter of 2021 unless otherwise stated.

Some non-metric units are used in the report because of prevailing industry or market practice. Gold and silver weights are reported in troy ounces (oz).

Table 2-2 below summarizes the nomenclature used in this report.

Table 2-2: Nomenclature and Units of Measure

Prefixes	M k c m μ	mega kilo centi milli micro	million thousand one hundredth one thousandth one millionth
Weight	g kg t st kt g/t oz koz klbs Mlb	gram kilogram tonne, metric, dry basis short ton, dry basis kilotonne grams/tonne (metric) troy ounce kilo ounce kilo pounds million pound	1,000 grams 1,000 kilograms 2,000 pounds 1,000 tonnes, metric 31.103477 grams 1,000 troy ounces 1,000 US pounds 1,000,000 US pounds
Length	m km	meter kilometer	1,000 m
Volume	li m ³	liter cubic meter	1,000 ml or cm ³ 1,000 liters
Temperature	°C	degrees Celsius	
Pressure	Pa kPa MPa	pascal kilopascal megapascal	
Power & Energy	W kW MW kWh	watts kilowatt Megawatt Kilowatt-hour	1,000 watts 1,000,000 watts

3 RELIANCE ON OTHER EXPERTS

This report has been prepared by M3 to professional standards in the industry and is co-authored by Justin M. Black, PE, and Richard K. Zimmerman, MSc, RG, consultants, of M3 Engineering & Technology Corporation (M3); Art S. Ibrado, PhD, PE, consultant, of Fort Lowell Consulting PLLC; and Michael G. Hester, FAusIMM, consultant, of Independent Mining Consultants (IMC);.

The information, conclusions, opinions and estimates contained herein are based on:

- information available to the authors of this report up to and including the effective date of this report;
- assumptions, conditions and qualifications as set forth in this report; and
- data reports and other information supplied by Chesapeake and other third party sources.

The authors of this report have relied on ownership information provided by Chesapeake. Chesapeake has obtained a title opinion by Heiras y Asociados, S.C. dated August 28, 2019, which certifies the legal status of the mineral concessions described in Sections 4.2 and 4.3 of this report. None of the authors of this report have researched or verified property title or mineral and land access rights for the Metates property.

4 PROPERTY DESCRIPTION AND LOCATION

4.1 PROPERTY LOCATION

The property is located in the northwestern portion of the Durango State, Mexico about 160 km northwest of the city of Durango and 175 km north of the coastal resort city of Mazatlán (Figure 4-1). Geographic coordinates of the Metates deposit area are 24°55'N latitude and 106°23'W longitude, and the UTM coordinates are 2,755,000N and 360,000E (NAD83).

4.2 LAND AREA AND MINING CONCESSION DESCRIPTION

The Metates property comprises twelve contiguous mining concessions totaling 4,260.7 hectares in area. These concessions are held in the name of American Gold Metates, S. de R.L. de C.V., an indirect 99.9%-owned subsidiary of Chesapeake. All of these concessions, except for San Miguel, are in good standing with all applicable taxes, payments, and filings being in good order. San Miguel is currently under an application for a reduction in size. The concession boundaries are surveyed. The annual cost (taxes) to maintain all the concessions is currently about US\$ 60,000 per year. Specific information on the mineral concessions in the Metates area can be found in Table 4-1 and are shown in Figure 4-2.

Table 4-1: Mining Concessions

Metates Area	Title No.	Inception	Hectares
San Vicente	170663	6/11/1982	105
Ampl. 1 San Vicente	170664	6/11/1982	235
Ampl. 2a San Vicente	170665	6/10/1982	185
San Vicente 3	204762	4/27/1997	700
Metates	214356	2/11/1994	1,195
Metates Sur	236913	9/30/2010	98
Metates Sur I	237017	9/30/2010	6.0
Metates Sur II	236876	9/30/2010	100
Metates Sur 3	236875	9/30/2010	6.6
Metates Sur 4	237016	10/19/2010	118.6
Metates Sur 5	244103	06/02/2015	520
San Miguel	23274	8/19/2008	991.6
Total			4,260.7

* All concessions expire 50 years after inception.

In Mexico, mineral rights and surface rights are generally severed, and such is the case at the Metates site. Chesapeake will need to reach agreement with the surface owners to allow for future site development, as described more fully in Section 4.3.

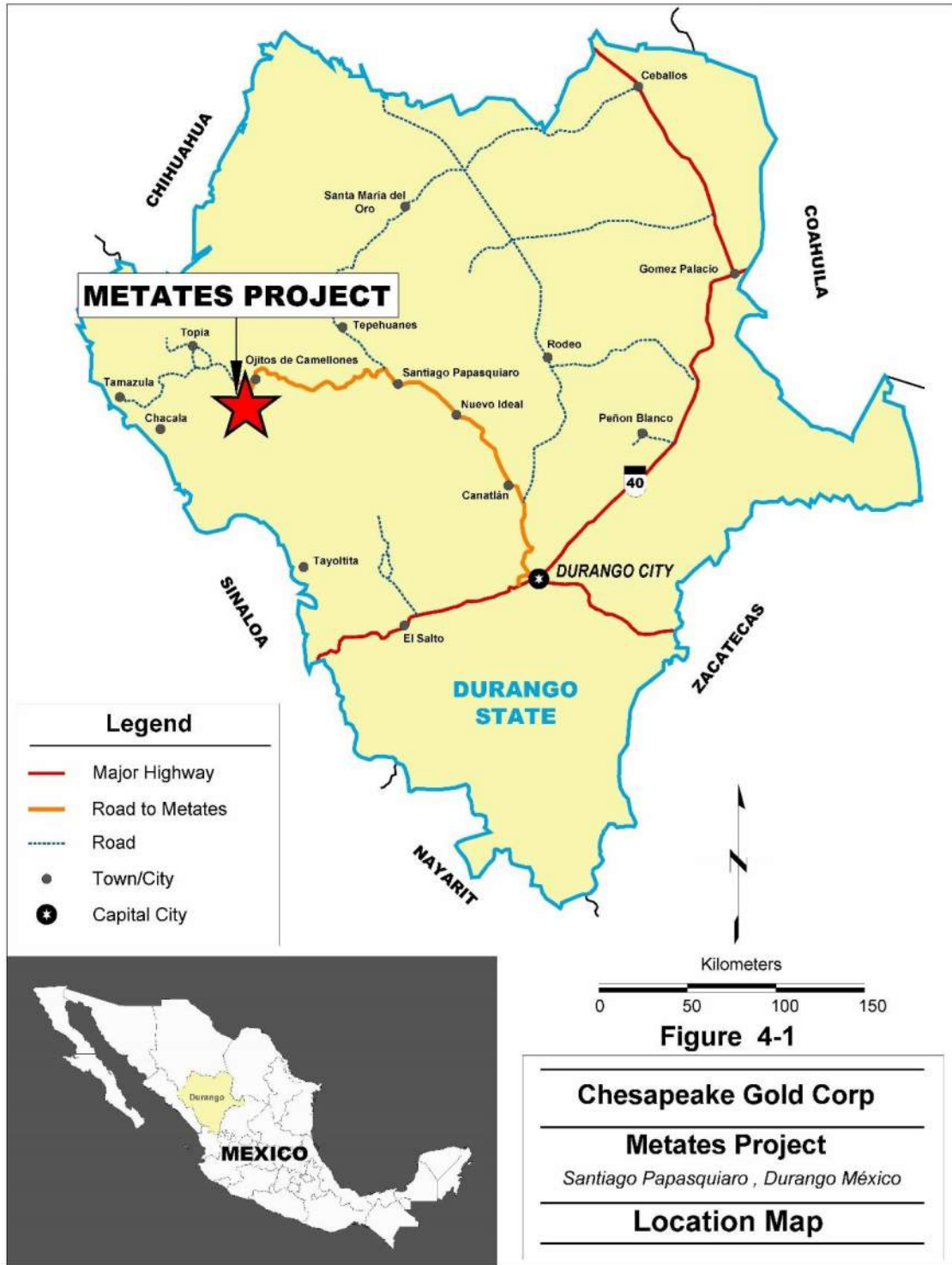

Figure 4-1: Site Location Map

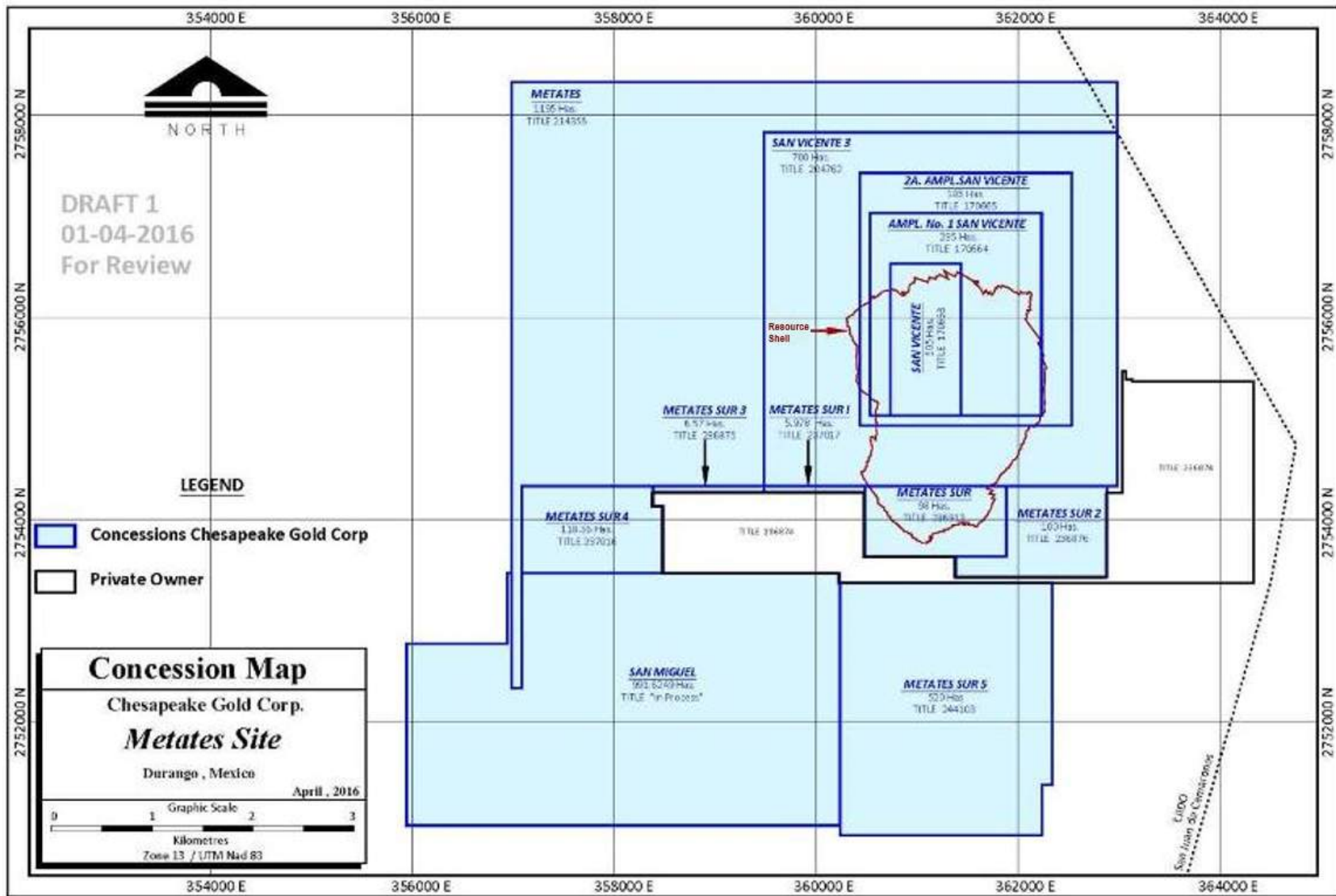

Figure 4-2: Mining Concessions in the Metates Area

4.3 AGREEMENTS AND ENCUMBRANCES

Chesapeake Gold Corp. is a publicly traded company headquartered in Vancouver, British Columbia, Canada, and is listed on the TSX Venture Exchange under the symbol CKG. On February 23, 2007, Chesapeake completed an agreement with American Gold Capital Corporation wherein American Gold merged its assets into those of Chesapeake with Chesapeake being the surviving company. The Metates property was one of the mineral property assets of American Gold that was part of this merger. As such, Chesapeake now owns a 100% undivided interest in the Metates mineral property. American Gold acquired the Metates property in February 2004 from the former owners, Wheaton River Minerals Ltd. ("Wheaton") and Glamis Gold Ltd. ("Glamis"). Wheaton acquired its 50% interest in the Metates property through purchase of Luismin S.A. de C.V. ("Luismin") in 2002. Glamis held the other 50% interest in Metates, which it had acquired through its purchase in 2000 of all of the Mexican assets of Cambior.

Documents indicate that a royalty was created in 2002 between Luismin and a subsidiary company of Luismin that apparently imposes a 3.0% net smelter return royalty over the Metates concessions. In 2004, on or about the same time as the American Gold acquisition of the Metates Project, this royalty was revised to be 1.5% over the Metates concessions. In April 2014, Chesapeake exercised its right of first refusal to purchase this 1.5% net smelter returns royalty from Luismin for a total consideration of US\$9.0 million. In August 2014, Chesapeake assigned this 1.5% royalty to Wheaton Precious Metals (Cayman) Co., a subsidiary of Silver Wheaton Corp., in consideration of US\$ 9.0 million. As part of this assignment Chesapeake retains the right to buy two-thirds of this royalty (leaving 0.5% to Silver Wheaton) for US\$9.0 million at any time up to five years after the original assignment. Chesapeake exercised the right to buy back this two-thirds royalty in August 2019. Chesapeake will also hold a first right of refusal should Silver Wheaton elect to sell their royalty to a third party. Further, Wheaton shall have a right of refusal over any silver stream or royalty offer that may be received by Chesapeake in the future.

The area of the Metates mine site and facilities is part of the Community/Ejido of San Juan de Camarones (SJC). In October 2008, an initial five-year agreement was signed with the ejido of SJC which permits the company to undertake exploration and evaluation work. Annual payments (in US dollars) are a combination of an annual fixed payment over successive 5-year terms of each agreement along with a variable annual support payment. The fixed payment for the term starting in 2008 was US\$53,580, the fixed payment for the term starting in year 2013 was US\$133,324 and extended for an additional year ending in 2019. The fixed payment starting in year 2019 is US\$135,000 and covers a 6 year term, expiring in October 2025. The annual payments made since 2008 until 2020 have totaled US\$1,787,560 and the detailed annual payments are shown below:

2008	\$53,580
2009	\$64,296
2010	\$77,155
2011	\$92,586
2012	\$111,104
2013	\$193,274
2014	\$170,810
2015	\$183,858
2016	\$171,757
2017	\$171,566
2018	\$193,326
2019	\$135,000
2020	\$169,248

Two additional special agreement renewal or extension payments of US\$140,066 in 2018 and US\$27,233 in 2020 were made, increasing the total payments to US\$1,954,859.

METATES SULPHIDE HEAP LEACH PROJECT - PHASE 1
FORM 43-101F1 TECHNICAL REPORT

In addition, the company agreed to upgrade and improve 45 km of off-highway road access to Metates and to contribute to community improvements in the amount of US\$875,000 over the terms of the earlier agreements. These payments and other obligations have now been fulfilled.

A different and more comprehensive agreement would have to be negotiated with the ejido of SJC to allow for the future development and operation of the Metates mine and process facilities.

5 ACCESSIBILITY, CLIMATE, LOCAL RESOURCES, INFRASTRUCTURE AND PHYSIOGRAPHY

5.1 ACCESS

Flight access to the Metates site from Durango City, Durango State, and from Mazatlán, Sinaloa State, or from Culiacán, Sinaloa State, is about one hour via fixed wing aircraft. All of these cities have regularly scheduled commercial air service. There is a paved 500 meter air strip at the village of Vascogil, adjacent to the Metates site, as well as several 200 to 500 meter long dirt air strips in the general Metates area. There is also a 1,000 meter paved air strip in Cosalá. Alternatively, the property can be reached by road in about 7 hours from Durango, with a total distance of about 364 road km. The road from Durango to Santiago Papasquiario, and then on to El Ojito de Camellones, is paved and is 314 km in length. From El Ojito de Camellones, there is a further 50 km of variable quality dirt road, which allows access to Metates and the surrounding villages of Vascogil and San Juan de Camarones. The dirt road portion of this route is occasionally blocked during the rainy season, but it does allow for the transport of heavy equipment and drill rigs. There is currently not an all season direct road access to the Metates site from the west.

5.2 CLIMATE

The climate is variable (from subtropical to temperate) because of the property's location and elevation extremes. The dry season is generally from October through May, and the wet season from June through September. Approximately two-thirds of the average of 1,025 mm of annual rainfall at the Metates site occurs during the monsoonal wet season. During May and June, temperatures can reach 40°C at the lower elevations, and during December and January, sub-zero temperatures and snow can be expected at higher elevations. An automated weather station was installed at the property by Cambior in May, 1995, but was replaced by a new automated weather station installed by Chesapeake in May 2009. This weather station has collected continuous records since that time except for a few brief outages. Because of the short data collection period, climatic data from five government meteorological stations representing 46 years of record, all within a 45 km radius of the property, were used to generate climate data used in this study after adjusting for elevation. Average annual evaporation is estimated at 1,406 mm. The climate at site is amenable to year-round mining and processing operations.

5.3 LOCAL RESOURCES

There are several small villages scattered throughout the general area of the Metates site: San Miguel El Alto, population about 350, located about 8 km south of the Metates camp; San Juan de Camarones, population 300, located about 5 km southwest of the camp; and Vascogil, population about 150, located about 2 km to the south of the camp. The village of Vascogil may have to be relocated, should a mining operation be established at Metates. The village of Vascogil has about thirty houses and was established about 30 years ago. The living conditions are primitive in this isolated, mountainous area, where the roads are sometimes impassable during the rainy season. Running water is sometimes available where sourced from local springs, while electricity is generated by gas- or diesel-powered generators. There is no landline-based telephone service. Economic activity consists of subsistence agriculture and cattle ranching.

If operations are established at the Metates site, the majority of the workforce and services would come from the larger population centers, such as Mazatlán, Culiacán, Durango, etc. Due to its remoteness, a mine camp would be established at the Metates site to house employees.

5.4 INFRASTRUCTURE

A 50-person camp was established at Metates by Cambior, which included houses, dormitories, and a cafeteria, along with core logging, sawing, and storage facilities. Chesapeake has rehabilitated and expanded these camp facilities in support of its drilling, exploration, and evaluation programs.

National power grid electricity is currently available about 20 km from the Metates site at Fresnillo's La Ciénega Mine. Mining and processing operations at Metates will require the construction of a new power line. A more thorough discussion of electric power and water supply is contained in Section 18 of this PEA.

Water balance and water supply discussions are included in Section 18 of this report. A water storage reservoir will be constructed near the Metates site. This reservoir will be located in large drainage basin to intercept and store water during the rainy season and then allow for the consumption of this water throughout the dry season. This water supply will be augmented by water collected from mine pit dewatering wells at Metates.

5.5 PHYSIOGRAPHY

The Metates Project site is located within the rugged Barranca Province of the northwest-southeast-trending Sierra Madre Occidental Mountains. Elevation in the general Metates area varies from about 600 m in the canyon bottoms to near 2,600 m along the ridge lines, with much of the topography consisting of steep slopes or cliffs. In the area immediately surrounding the deposit, the elevations vary from 800 to 1,200 m.

Vegetation is quite diverse in the Metates area. Below about 900 m elevation, the area is covered by oak trees and other sub-tropical type Mediterranean trees, bushes, and some cacti. Above about 1,200 m elevation, the vegetative cover is predominantly pine forest, with a mixed assemblage between 900 and 1,200 m.

6 HISTORY

Table 6-1 outlines the history of exploration/mining at Metates, from the early Spanish colonial times of the 17th and 18th centuries to the present. In contrast to many mining properties in Mexico, there has been little evidence of historic mining activity in the Metates area. This is likely a result of the remote location, the lack of any high grade veins, and the refractory nature of the gold and silver mineralization. The first extensive work on the property is thought to be that of Sr. Roberto Erraguin. He developed at least one adit targeting mineralization in the sediments, and also possibly an adit into the intrusive hosted mineralization as well. The locations of both of these adits are known and the adit in the intrusive is open, while the sedimentary adit has caved. The remains of the small mill are still on the site including some processed tailing and mineralized material.

From 1980 to 1983, Minas Frisco and a subsidiary of British Petroleum formed a joint venture (“Frisco/BP”) and followed up on the earlier work of Sr. Erraguin, drilling numerous holes that targeted primarily the sedimentary-hosted base-metal-rich sulphide mineralization. Nearly all of the holes drilled during this campaign were directed toward this target, but three holes were drilled into the intrusive hosted mineralization. For the most part, the Frisco/BP holes were not assayed for gold and silver. Much of the core from this drilling was still available and was re-logged and assayed by Cambior.

In 1987, the Frisco/BP venture terminated its exploration and returned the property to Sr. Erraguin after which Luismin, a Mexican focused mining subsidiary of Corporación San Luis, optioned the concessions. Luismin conducted early stage exploration, including surface geochemistry and geophysics, and determined that the intrusive hosted mineralization represented a large tonnage, disseminated-type deposit. Luismin subsequently drilled four deep core holes in 1992, targeting the most geochemically anomalous area and intercepted significant lengths of continuously mineralized material with low grade gold and silver. After reviewing the results, Luismin elected to seek a joint venture with a major mining company to earn-in on the property.

In early 1993, Cambior, a publicly traded Canadian company, entered into a joint venture with Luismin whereby Cambior could earn an initial 50% of the property through a combination of exploration expenditures and the preparation of a feasibility study. As part of its joint venture earn-in obligations between 1993 and 1997, Cambior carried out extensive work on the Metates property, culminating in the preparation of an internally prepared Preliminary Feasibility Study, dated July 1997. The preparation of this report was required for Cambior to gain an undivided 50% interest in the property from Luismin. The work performed by (and for) Cambior is crucial to understanding the property’s potential. As such, the authors and their associates have studied the results and conclusions of the PFS including a detailed review of the assay database, an extensive review of the metallurgical testing performed during this period, an evaluation of the various metallurgical processing options, and a review of the capital costs, operating costs, and financial analysis for the project.

The Cambior PFS was completed prior to the inception of NI 43-101 regulations and is considered to be non-compliant. However, the current Chesapeake Vice President Development, Gary A. Parkison, was also the Metates Project Manager with Cambior at the time that this work was being performed, and personally supervised much of the work. Therefore, he can verify that this work was done to high professional standards and can be considered accurate and reliable. Independent Mining Consultants (IMC) also had extensive involvement in the development and maintenance of the drill hole database, development of the resource models, mine design and planning, and development of the historic mineral resources and mineral reserves for that study. Frequent reference may be made to this Cambior work in the following sections of this report.

Following the 50% earn-in to Metates following the delivery of the July 1997 study, Cambior and Luismin discontinued active operations at the Metates site and placed the project on care and maintenance. The Mexico assets of Cambior including Cambior’s 50% interest in Metates were sold to Glamis Gold in 2000. In 2002, Luismin was sold to a Canadian mining company called Wheaton River including Luismin’s 50% interest in Metates. The Glamis/Wheaton River JV at

**METATES SULPHIDE HEAP LEACH PROJECT - PHASE 1
FORM 43-101F1 TECHNICAL REPORT**

Metates reviewed the information generated by the prior JV, and commissioned some outside studies, but did not perform any work at the site. American Gold Capital acquired the Metates JV interests in 2004 and effectively consolidated a 100% interest in the project. American Gold also did not perform any on-site activities, but maintained the mining concessions in good standing.

Chesapeake acquired the Metates property from American Gold in 2007, and has completed a program of extensive drilling and related assaying in order to validate the Cambior data and to allow for its incorporation into a series of NI 43-101-compliant mineral resource estimates. In addition, Chesapeake has completed a series of NI 43-101-compliant technical reports including PEAs and PFSs.

Table 6-1: Property History

Date	Entity	Work Program	Significant Results
Pre-1978	Spanish colonists and artisanal miners	Small-scale mining in district	None recorded
1978	Roberto Erraguin	25 tpd mill to treat mineralized material from vein structures in sediments	None recorded
1980-1983	Minas Frisco/BP	28 diamond drillholes	Both sedimentary and intrusive mineralization were intersected
1987-1992	Luismin	4 diamond drillholes	Tonnage calculated on Main Zone (intrusive)
1993-1997	Cambior/Luismin JV	Intensive drilling/ Preliminary Feasibility Study	Large tonnage/low grade deposit outlined
1998-1999	Cambior/Luismin JV	Property idle	
2000-2002	Ownership changes	Property idle	
2003-2004	Wheaton/Glamis JV	Resumption of work contemplated, but none performed	None recorded, but NI 43-101 report published by WGM
2004-2007	American Gold	Property acquired by American Gold, but no work undertaken on-site	None recorded
2007-2008	Chesapeake	Engineering studies and 37 core drillholes	NI 43-101 Report
2009-2010	Chesapeake	Metallurgical and engineering studies	NI 43-101 Preliminary Economic Assessment
2011	Chesapeake	Continued metallurgical and engineering studies; extensive drilling	NI 43-101 Updated Preliminary Economic Assessment
2012-2013	Chesapeake	Metallurgical and engineering studies	NI43-101 Preliminary Feasibility Study
2014-2016	Chesapeake	Limited drilling, extensive engineering and infrastructure studies	Updated NI 43-101 Preliminary Feasibility Study
2017-2019	Chesapeake	Limited scale metallurgical testing	
2020-2021	Chesapeake	Metallurgical testing of new oxidation technology, limited drilling program	NI 43-101 Preliminary Economic Assessment

7 GEOLOGICAL SETTING AND MINERALIZATION

7.1 REGIONAL GEOLOGY

The regional geology of this portion of the rugged Sierra Madre Occidental is poorly described in the published literature, with only reconnaissance style, regional type, government-supported maps available at scales from 1:50,000 to 1:250,000. Figure 7-1 presents a portion of this 1:250,000 scale geologic map. It shows that the majority of the Sierra Madre Occidental is underlain by Tertiary age (approx. 25 million years) volcanic rocks, typically flat-lying, which have been divided into the older Lower Sequence, comprised of andesite flows and breccias, and the younger Upper Sequence, comprised mostly of rhyolite ash flow tuffs or ignimbrites. The Lower Sequence can be up to several hundred meters in thickness while the Upper Sequence can be up to a thousand meters in thickness.

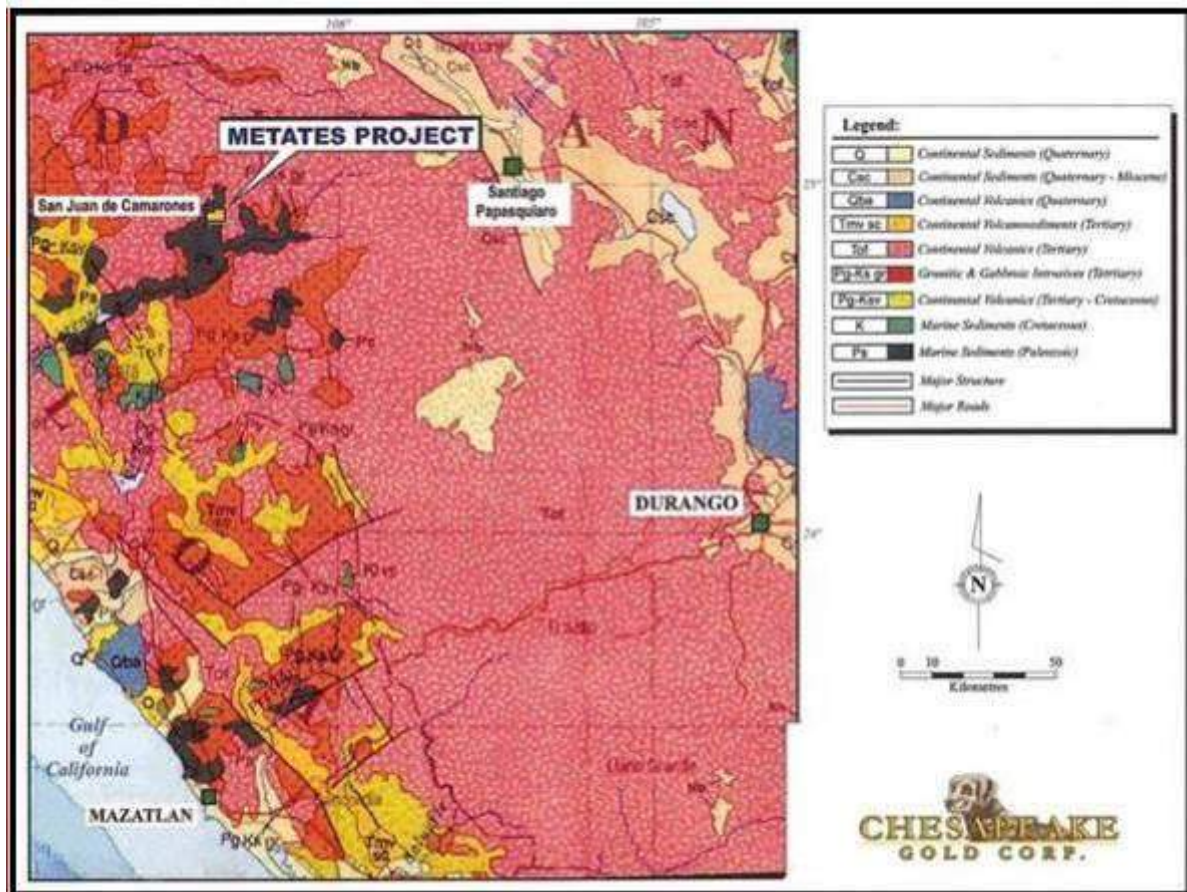

Figure 7-1: Regional Geology, Chesapeake 2016

7.2 LOCAL GEOLOGY

The local geology shows that the Metates site is situated within a window of Mesozoic basement rocks, exposed by erosion of the extensive flat-lying Tertiary volcanic cover. The basement complex of Cretaceous- to Jurassic-aged rocks consists of a monotonous sequence of interbedded sandstones, shales, and argillites. In general, the lower horizons are finer-grained and thinly bedded, with the grain size and bedding thickness tending to increase up-section. The sedimentary package measures at least 1,000 m in exposed thickness, but the true thickness could be somewhat less, due to the presence of intra-formational thrust faulting and isoclinal folding.

Given the general lack of identifiable marker horizons, the true thickness of the sediments is difficult to determine with precision. A variable amount of black carbonaceous material is present throughout the sequence, with organic carbon content ranging up to greater than 1% locally. Pyrite is a common constituent of all the sedimentary rocks, and is commonly present as thin laminations, as disseminated framboidal biogenic pyrite, or as irregular veinlets or stockworks. Overall, pyrite content in the sedimentary rocks is typically in the range of 3% to more than 10%, but locally can be higher. The stratigraphy is indicative of a submarine seafloor distal flysch depositional environment.

A preserved thickness of up to 160 m of conglomerate is present in the upper portion of the Mesozoic sedimentary sequence. The conglomerate contains rounded to subrounded pebbles to boulders of sandstone, and subordinate shale, chert, volcanic rock, and quartz fragments in a sandy-to-shaley, well-indurated matrix. The conglomeratic beds are often interbedded and overlain with arkose and argillite.

Regionally, the sandstones and shales generally strike to the northwest and dip 30°-50° to the northeast. This orientation in the shales and sandstones is common within the Metates area and within the proposed pit to the northeast of the conglomerate and to the southwest of the intrusive. In the 700-m wide corridor between the intrusive and the conglomerate, the sandstones and shales are broadly folded in a synform. The contact with the undeformed conglomerate shows indications of faulting and the contact with the intrusive is often brecciated. The conglomerate and intrusive are not noticeably deformed, which may be related to their “buttressing” effects with most deformation within the softer sediments.

A felsic igneous body, interpreted to be a subvolcanic to extrusive volcanic dome, is broadly conformable with the enclosing sedimentary rocks, and is referred to as the Metates Intrusive. The body is in the shape of an inverted saucer, and is oriented in a northwest/southeast direction, dipping approximately 40° to the northeast. It is approximately 1,500 m long and up to 300 m thick. The body is quartz latitic in composition, containing approximately 50% phenocrysts (quartz, biotite, and feldspars) set in an aphanitic groundmass. The rock exhibits a texture ranging from igneous to volcanic. Pyrite content in the Metates Intrusive, like the surrounding sedimentary rocks, is typically in the range of 5% to more than 10%. The upper contact between the Intrusive and the overlying sediments, can be upwards of 100 m thick, and is comprised predominantly of a breccia body, informally referred to as the intrusive breccia. The breccia is generally composed of rounded igneous clasts and igneous-derived matrix, with a progressively larger amount of sedimentary matrix and sedimentary clasts going up-section, away from the core of the igneous body. Several radiometric age dates have been obtained from the Metates Intrusive. A U-Pb date has been obtained on a zircon separate, and indicates an emplacement age of 108 million years (“Ma”). Ages of 87 and 89 Ma, which likely represent an alteration age, have been obtained on sericite by K/Ar methods. A Rh-Os date on pyrite from both the sediments and the Intrusive was attempted but was thwarted by abnormally low amounts of rhenium.

The Tertiary sequence at Metates consists primarily of the Lower and Upper Volcanic Sequence and are thought to be post-mineralization. In the Metates area, the Lower Volcanic Sequence is a 100- to 150-meter-thick sequence of andesitic flows and breccias, which have locally been propylitically altered. A conglomerate of variable thickness (up to 60 m) is known to locally underlie the Lower Volcanic Sequence rocks. This unit is distinct from the Mesozoic conglomerate but could be a local erosional accumulation of it. It appears to be altered and mineralized, possibly with local secondary enrichment of silver. The Upper Volcanic Sequence is composed of cliff-forming rhyolite ash flow tuff units and is up to 700 m thick in the immediate vicinity of the project. Talus or colluvial deposits up to 50 m thick cover much of the project area and are derived predominantly from erosion of the ash flow tuff units. A simplified geologic map of the project area is shown in Figure 7-2, while a geologic map of the immediate area of the proposed pit is shown in Figure 7-3. A schematic geologic cross-section across the trend of mineralization is shown in Figure 7-4. The outline of the final pit on these figures refers to the resource cone related to the total mineral resource estimate presented in Section 14.

**METATES SULPHIDE HEAP LEACH PROJECT - PHASE 1
FORM 43-101F1 TECHNICAL REPORT**

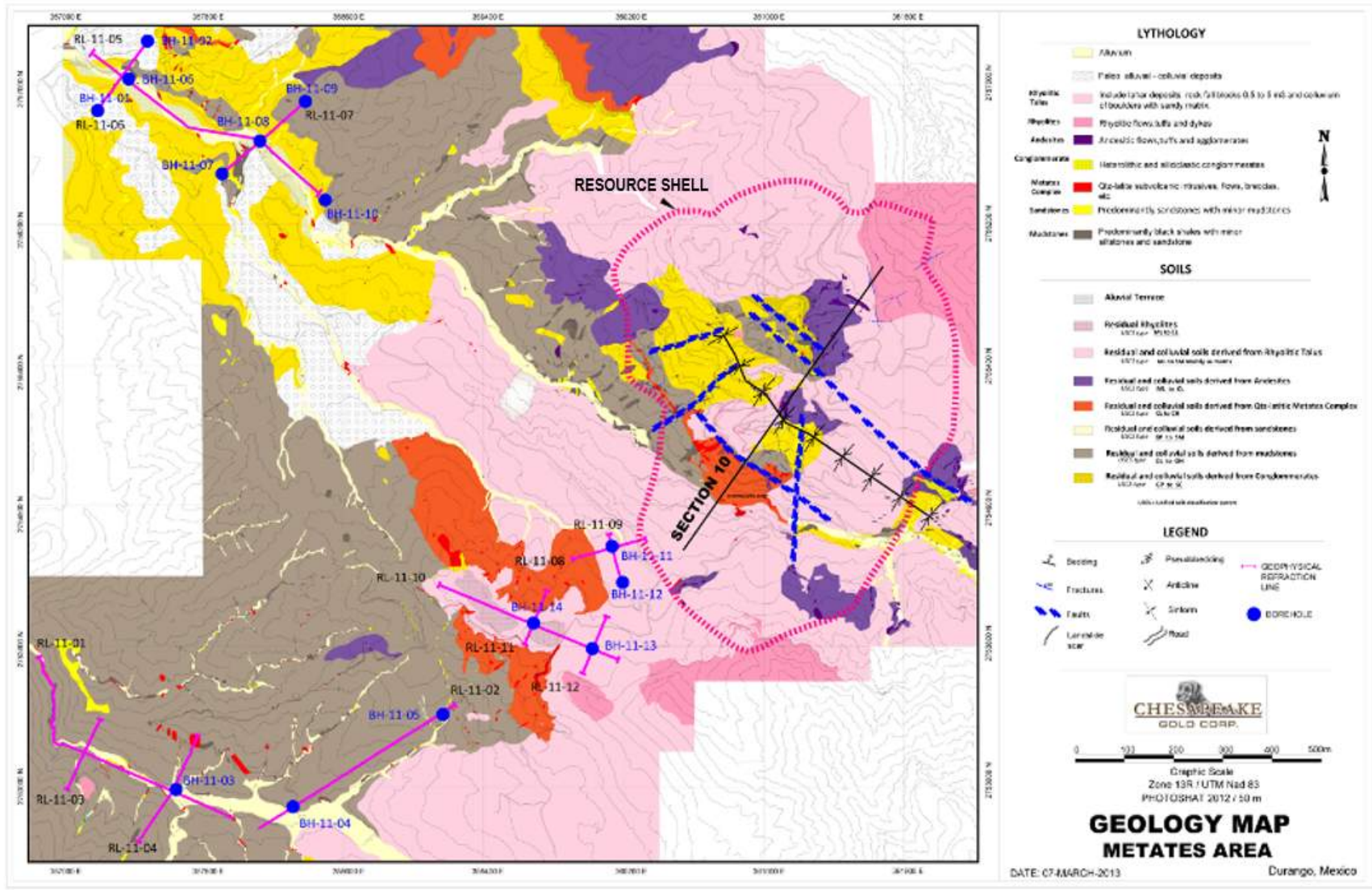

Figure 7-2: Geology of the Metates Area, Chesapeake 2016

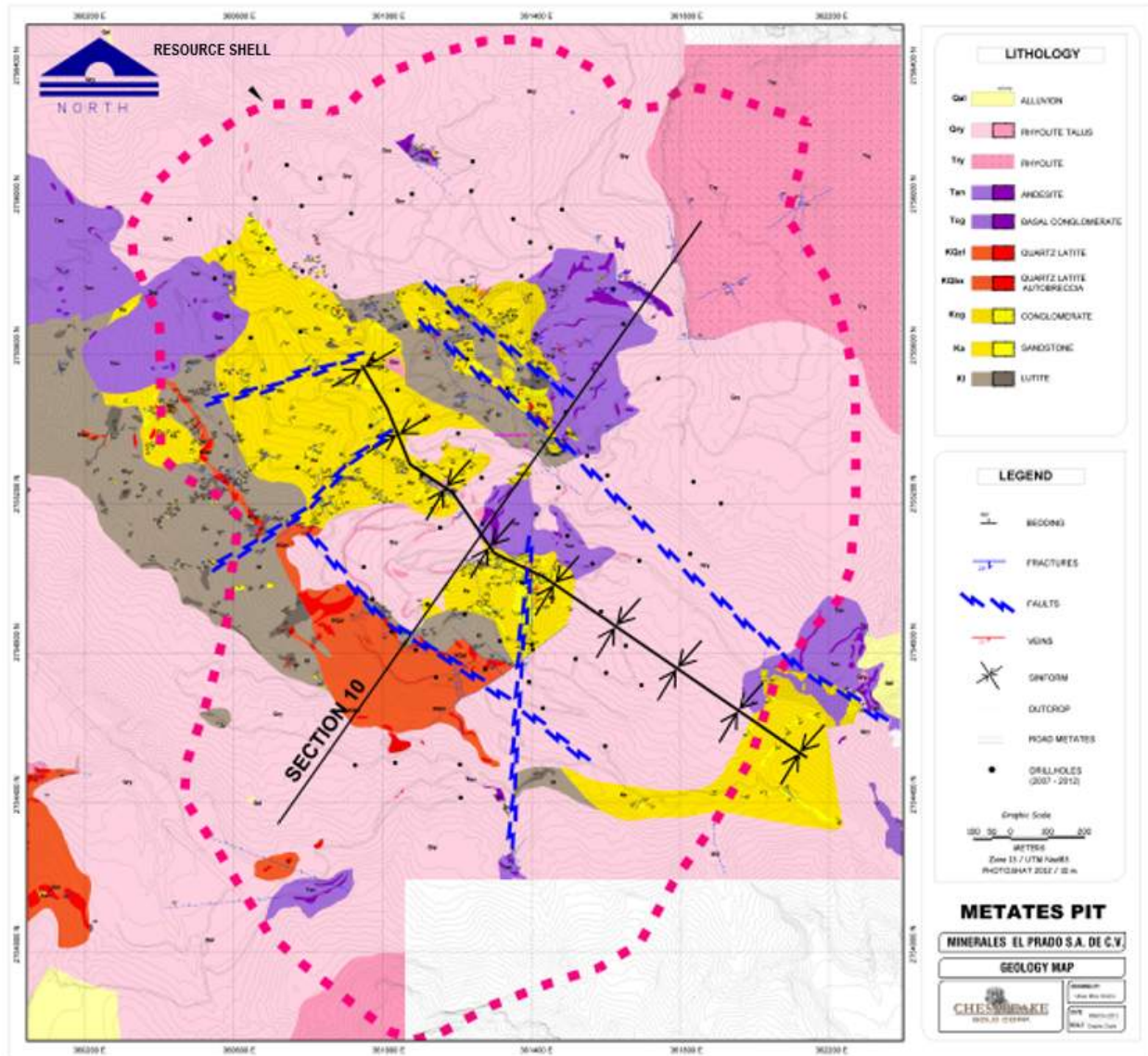

Figure 7-3: Geology of the Metates Pit Area, Chesapeake 2016

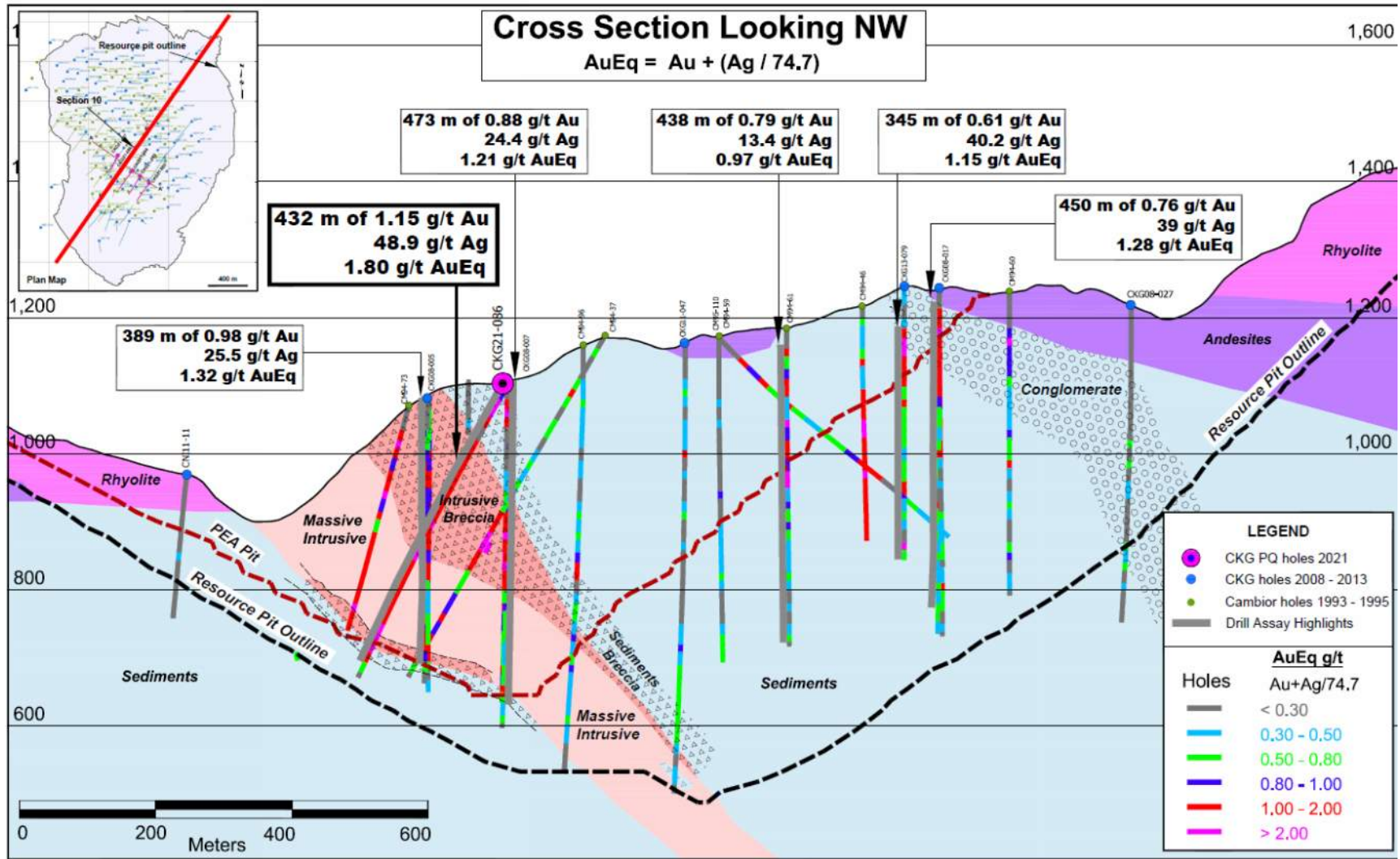

Figure 7-4: Geology and Mineralization on Cross Section 10,300E, Chesapeake 2021

7.3 STRUCTURE

The Mesozoic sedimentary sequence generally strikes northwest and dips between 30° and 40° to the northeast. Folding generally parallels the strike of the sedimentary rocks and tends to be of a concentric to isoclinal nature. Faults have often developed parallel to isoclinal fold axes. Soft-sediment deformational features are common in the sedimentary units. The Metates Intrusive is oriented in a northwest-southeast direction, dipping 40° to the northeast, and is broadly conformable to the trend of the surrounding sediments. The upper contact of the Metates Intrusive is a sedimentary or erosional type breccia or conglomerate (owing to the rounded clasts), while the lower contact is quite regular and could be a fault.

Major high angle faults in the project area trend northwest to northeast. Faults of a northeast orientation may possibly offset the Metates Intrusive, and have caused deformations and drag folds where they cut the sediments. Northwest trending faults are common, and trend parallel to the strike of the sediments.

Within the sedimentary rocks, fracture directions and sulphide veinlets most commonly trend north-northeast. Stockwork mineralization follows fractures in the intrusive body, with the most common orientation being northwest-southeast.

The Upper and Lower Volcanic Sequences are not deformed and tilt in a homoclinal nature gently to the east.

7.4 ALTERATION

Three types of alterations have been recognized at Metates. These alteration effects are most recognizable within the more reactive Metates Intrusive, where phyllic alteration has been very extensive, with feldspar and biotite phenocrysts being replaced by sericite and pyrite, respectively, and the groundmass being almost entirely replaced by fine-grained sericite and quartz. Argillic alteration within the Metates Intrusive body is poorly developed and is of only local extent. Variable but weak amounts of silicification have been noted, but in general there is no pervasive silicification within either the intrusive body or the surrounding sedimentary rocks. Because of the fine-grained and generally non-reactive nature of the sedimentary rocks, visible alteration effects are not well developed, although a weak propylitic alteration is generally quite common and widespread. No distinct contact metamorphic effects have been noted surrounding or adjacent to the contact between the intrusive body and the enclosing sedimentary rocks, suggesting it was emplaced at a relatively low temperature and possibly high level.

7.5 MINERALIZATION

Sulphide mineralization within the project area is thought to be both syngenetic and epigenetic in origin. Syngenetic mineralization is fairly widespread within the sedimentary rocks and is typical of rocks formed in a black-shale or euxinic environment. Very little, if any, precious metal mineralization is thought to be associated with this phase of predominantly pyritic mineralization. Epigenetic mineralization may have occurred as two separate mineralizing events in both the sedimentary rocks and in the intrusive rocks, but it is possible that the mineralization in the sediments represents an earlier and more distal event that is related to an emerging intrusive dome, which subsequently intruded part of the sedimentary hosted mineralization.

Mineralization is most typically expressed as sulphide stockwork veinlets or disseminations. Within both the sedimentary and intrusive rocks, veinlets are typically composed almost completely of pyrite, sphalerite, arsenopyrite, and galena, with very little gangue mineralization, such as quartz, calcite, or barite. Veinlets are typically 1 to 5 mm in thickness, sometimes exceeding 1 cm, and are generally banded with layers of pyrite, sphalerite, and/or galena. Within the intrusive, feldspar and biotite phenocrysts are commonly replaced by pyrite and sphalerite, with the individual pyrite crystals generally several millimeters in size. Sphalerite and galena inclusions are common within disseminated and veinlet pyrite.

Extensive mineralogical investigations indicate that some amount of native gold and electrum occurs as both rare free mineral grains, as micron-sized grains that are generally enclosed within the pyrite grains, or as solid solution within the crystal structure of the pyrite in both sedimentary and intrusive host rocks. The majority of the gold is associated with pyrite either as solid solution or as inclusions although there is some amount of coarser, visible gold (>20 micron). Extensive metallurgical investigations have demonstrated that the gold is largely refractory or not amenable to routine cyanidation, even when the material is finely ground. Most silver mineralization is associated with the mineral pyrargyrite or as a solid solution within the copper mineral tetrahedrite. Commonly both of these minerals are found as inclusions within galena (AMTEL, 2020). These same metallurgical investigations show that silver is also refractory, but to a lesser degree than gold.

Gold and silver mineralization is associated with the sulphides replacing feldspar and biotite phenocrysts, with sulphide veinlets, and with sulphide stockworks. Sulphide sulphur content of mineralized sedimentary and intrusive rocks is typically in the range of 3% to more than 10% by weight, a reflection of the high percentage of pyrite in these rocks. There is generally a positive correlation between pyrite content and gold and silver grades. The sedimentary rocks also contain up to about 1% of organic carbon, which results in the mineralization in these rocks having both refractory and mildly "preg-borrowing" characteristics. (Preg-borrowing occurs when the gold and silver extracted by cyanide is then adsorbed on the organic carbon rendering it unavailable for routine recovery.) Multiple mineralizing episodes are suggested, based on the cross-cutting and mineralized breccia clast/host relationships. Oxidation of the Metates mineralized system has been very limited, with the depth of oxidation generally not exceeding 5 to 10 m, and it is not uncommon to see fresh sulphides at surface.

8 DEPOSIT TYPES

The Metates deposit is broadly analogous to several other deposits commonly known in Mexico, as well as the Pueblo Viejo deposit in the Dominican Republic. However, these deposits are not so well-known or numerous as to constitute a recognized deposit type. A simplified model for the geologic evolution and mineralization at Metates is proposed as follows:

1. Deposition of Late Jurassic-Early Cretaceous submarine sediments in a largely euxinic, sea floor basinal environment conducive to development of syngenetic sulphides
2. Initiation of the emplacement of the Metates Intrusive body in the Early Cretaceous as a submarine volcanic dome of quartz latite/dacite in composition within the earlier sediments, along with continued sedimentation
3. Mineralizing solutions related to the Metates Intrusive result in distal sulphide mineralization hosted in sedimentary rocks along with contemporaneous mineralization in the intrusive
4. Continued evolution, growth, and uplift of the intrusive dome, resulting in intense alteration of the dome and the generation of related stockwork and disseminated sulphide mineralization within the dome coupled with replacement and stockwork-type sulphide mineralization in the sediments contemporaneous with continued sedimentary deposition
5. Continued uplift and growth of the submarine dome, resulting in subaerial or shallow submarine erosion of the dome and surrounding sediments generating mineralized igneous and sedimentary clast breccias surrounding the upper part of the dome as a carapace
6. Continued deposition of basinal sediments that gradually give way to coarser sediments and polymictic conglomerates with exotic clast types and with periodic mineralizing episodes related to the Metates Intrusive. Some of the folding in the sediments could be related to syn-sedimentary processes. Much sulphide could have been derived from the biogenic pyrite in the sediments and recycled through assimilation or alteration related to the Metates Intrusive
7. Cessation of the mineralizing episodes in the mid-Cretaceous
8. Subsequent folding, tectonic uplift, faulting, tilting, and erosion
9. Starting in the mid-Tertiary, deposition of the andesitic rocks of the Lower Volcanic Sequence, followed by the emplacement of the ash flow tuffs of the Upper Volcanic Sequence
10. Uplift combined with extensive and rapid erosion, generating extensive amounts of talus primarily from the rhyolite tuffs and eroding any zones of oxidation that may have developed

Any attempted classification of Metates into various deposit types should incorporate the following major characteristics:

- A general geologic setting of submarine sediments being intruded by younger altered intrusive rocks
- Alteration style of phyllic in the intrusive, no-to-minor contact metamorphic effects and minor alteration in the sediments, minor silicification
- An ore metal association of low-grade gold and silver with significant base metals, the gold and silver commonly present within sulphides (refractory)
- Pyrite-rich, high sulphide mineralization in both the intrusive and the enclosing sediments as both disseminations and veinlets and local sulphide replacements lacking well-defined veins
- Large mineral systems, typically 100 million tonnes or more of mineralized material

In Mexico, possible similar or analogous deposits could include: the Cerro de San Pedro gold-silver-zinc deposit of New Gold, Inc., in the state of San Luis Potosí; the Castillo Mine gold-silver-zinc property of Argonaut Gold in Durango State; and the Peñasquito silver-zinc-gold-lead deposit of Newmont, in Zacatecas State. All of these other deposits are relatively close to Metates and are generally in northwestern or north central Mexico. Published descriptions of other deposits outside of Mexico suggest that Metates may be similar to Barrick Gold Corporation/Newmont's Pueblo Viejo deposit in the Dominican Republic. In particular, Pueblo Viejo is hosted in submarine sedimentary rocks, has an association with altered intrusive rocks, and is very large in size. It also contains significant amounts of sulphides in both mineralized material and waste rocks and hosts significant gold and silver which are refractory in nature accompanied by considerable zinc and copper mineralization.

To our knowledge, there is not at this time a classic definition of these types of deposits in the geologic literature.

9 EXPLORATION

9.1 PRE-CAMBIOR EXPLORATION

In 1978, Roberto Erraguin constructed a 25 ton/day flotation mill on the site to treat silver-rich base metal from three small vein-like structures within the sedimentary rocks, which were exploited by at least one adit and several surface cuts. No records are available regarding the tonnage and grade mined, but it was likely quite small. The remnants of the mill remain on-site.

In 1980, Minas Frisco optioned the property, built the first road to the property (from Puerto de Temasquales), and formed a joint venture with BP Minerals. By 1983, the Frisco/BP joint venture had drilled 28 core holes totaling 5,891 m in the search for sedimentary hosted silver, gold, zinc, and lead mineralization. Twenty-five of the holes were drilled into the sediments in the silver-rich zone in the vicinity of the present camp, now known as the North Zone. Approximately 1,822,000 tonnes of mineralization (non-NI 43-101-compliant) was reported from this work grading 0.33 g/t Au and 106 g/t Ag. The three other holes were drilled into the felsic porphyry intrusive (Metates Intrusive) 1,000 m to the south where disseminated, low-grade, refractory gold-silver mineralization was intersected within altered intrusive rock. The low gold and silver grades and the refractory nature of the mineralization led to the cessation of the work and termination of the joint venture in 1983.

In 1987, Luismin optioned the property from Sr. Erraguin and subsequently located additional concessions and carried out limited mapping and geochemical sampling. Luismin purchased the core property and drilled four holes in 1992 totaling 1,331 m, estimating a preliminary "geologic resource" figure exceeding some 100 million tonnes grading about 1.0 g/t Au and 10 g/t Ag (non-NI 43-101-compliant) within intrusive rocks and immediately adjacent sediments. Upon the conclusion of the 1992 drilling program, Luismin elected to seek a major gold mining company as a joint venture partner to further evaluate and possibly develop the Metates Project.

9.2 CAMBIOR EXPLORATION

A joint venture agreement between Cambior and Luismin signed in April 1993 stipulated that Cambior could acquire a 50% interest in the Metates mining concessions by preparing a PFS, which Cambior issued on July 13, 1997.

Prior to drilling, Cambior carried out an extensive soil geochemical sampling program over a 1,500 by 1,500 m area with sample intervals at 25 m spacing along lines spaced 50 m apart. Samples were assayed for gold, silver, copper, lead, zinc, arsenic, antimony, and mercury. Large multi-element anomalies (gold and silver being the most diagnostic) outlined the Main Zone and North Zone and provided an early indication of the ultimate size of the deposit, assisting in the definition of the drill programs. Also, prior to drilling, a 12.5 line-km IP survey was carried out by Cambior over the mineralized areas as known at the time. The surface outline of the intrusive was defined by the 10 ohm-m resistivity contour, and it was recommended that the proposed drilling program take this into account.

Cambior carried out an extensive core drilling program that outlined two zones of low-grade gold and silver mineralization within the Metates property. The two zones comprised the sediment-hosted North Zone and the intrusive-hosted Main Zone. A small amount of reverse circulation (RC) drilling was carried out largely to pre-collar core holes through barren post-mineralization rock types. The Cambior drilling amounted to 148 holes and 49,060 m of drilling.

The overall size of the Main and North Zone deposits was defined by drilling on 100-m centers with portions of the Main Zone being drilled on 50- to 75-m centers. Only a few holes were drilled between the two zones/deposits by Cambior.

Regional and detailed geological mapping and additional geochemical sampling surveys were conducted in addition to the drilling and related activities. During the geochemical surveys, silt samples were taken at 500 m spacing along all

the drainage systems (arroyos) within an 8 km by 15 km area surrounding the Metates deposit. Gold and silver anomalies were defined downstream of Metates and in two other locations downstream of known mineralization. Other minor anomalies were identified but could not be explained by follow-up work. Few of the regional geological targets were recommended for additional work.

Cambior and various consultants and contractors carried out numerous other studies concurrent with and after completion of the drilling related to the “in-house” preparation of a PFS in July 1997. These studies included geology, mineral resources and reserve estimation, mine planning, metallurgy, processing, water and effluent management, environmental, infrastructure, reclamation and closure, operating and capital cost estimation, and economic evaluation/financial analysis.

9.3 CHESAPEAKE EXPLORATION

Chesapeake acquired the Metates property in February 2007. A core drilling program was initiated by Chesapeake in December 2007. The initial purpose of the core drilling program was to twin numerous Cambior drill holes in both the Main and North Zones to validate the results of the Cambior holes and to provide additional information on the sample preparation and analytical procedures and assays. Subsequently, infill drilling was completed between the two mineralized zones that were untested by Cambior, as well as some step-out holes targeting possible extensions outside the known mineralization. The program also provided drill core for a metallurgical test program. A total of 36 drill holes were completed in the 2007-2008 program for a total of 14,379 m.

Chesapeake geologists also re-logged all available cores remaining from the Cambior drilling programs. The Cambior drill hole locations were also re-surveyed for integration into a new topographic base map. Chesapeake conducted geologic mapping and geochemical sampling in the area surrounding the deposit and a regional reconnaissance program throughout the district. A LIDAR mapping survey of the site was also completed to generate detailed topographic maps of the entire project area. This topographic mapping was subsequently expanded with the use of satellite imagery.

In February 2011, Chesapeake initiated a core drilling program which included 53 holes and 23,486 m drilled. The purposes of the core drilling program were to infill between widely spaced holes to allow the conversion of Inferred Mineral Resources to Indicated Mineral Resources, drill geotechnical holes in support of pit slope stability investigations, and expand the overall Mineral Resource with step-out holes. An RC drilling program was conducted in 2012 for condemnation holes in and around the area of the proposed waste rock management and tailing storage facilities and the process plant site. Some of these holes were converted to groundwater piezometer holes. Reverse circulation drilling totaled 4,200.5 m in 27 holes.

In 2013 Chesapeake drilled five core holes primarily for metallurgical purposes within the central part of the mineralized zone totaling 2,018 m. Chesapeake completed a five-hole, large diameter (PQ size) core drilling program in 2021 to provide material for a column leach metallurgical study to evaluate the potential of alkaline sulphide oxidation in a heap-type setting, followed by precious metal recovery employing cyanide heap-leach methods. The 2021 drilling totaled 2,333 m bringing the total amount of core drilling at Metates by Chesapeake to 42,216 m in 99 holes. This drilling was not completed in time to incorporate the results of these holes into the mineral resource estimate used in this PEA.

10 DRILLING

10.1 GENERAL

Total Cambior and Chesapeake drilling amounts to 91,041 m of drilling in 234 holes. Table 10-1 shows this drilling by campaign. Cambior drilling amounts to 48,825 m in 140 holes, and Chesapeake drilling amounts to 42,216 m in 99 holes. Figure 10-1 shows the locations of the drillholes and distinguishes the Cambior and Chesapeake drilling.

Table 10-1: Summary of Drilling by Campaign

Company	Year	No. of Holes	Meters
Cambior	1993	14	4,827
	1994	92	33,499
	1995	34	10,499
	Subtotal	140	48,825
Chesapeake	2007–2008	36	14,379
	2011	53	23,486
	2013	5	2,018
	2021	5	2,333
	Subtotal	99	42,216
Total		234	91,041

10.2 PRE-CAMBIOR DRILLING

Prior to Cambior involvement with the project, drilling programs were carried out by the Frisco/BP Minerals joint venture and by Luismin. Cambior decided to not include this drill-related information in its subsequent resource block model estimates due to a lack of detail regarding the drilling, sampling, and assaying procedures, and they were not used in this study. No detailed description of the pre-Cambior drilling, logging, sampling, and assaying is provided in this report, as it is not considered relevant. However, Cambior drillholes essentially covered the same areas as these earlier drill programs.

10.3 CAMBIOR DRILLING

Cambior carried out extensive drilling programs in 1993, and from 1994 to 1995. The Cambior data used by IMC for this study included 140 drillholes and 48,825 m of drilling. About 5,338 m of this were drilled using RC, and the remaining 43,487 m were core drilled. Both core programs were carried out by Major Drilling de Mexico, S.A. de C.V., with two core rigs in 1993 and three core rigs in 1994 to 1995. An RC rig provided by Layne de Mexico, S.A. de C.V., was used in the 1994 to 1995 programs. The 1993 drilling was carried out on the intrusive-hosted Main Zone, with a nominal 200-m hole spacing where topography permitted. The 1994–1995 programs were carried out on both the Main Zone and the sediment-hosted North Zone, such that drilling on both zones was at nominal 100-m spacing with 50- to 75-m spacing in some areas. The Main Zone refers to the south and west sides of the deposit with intrusive host rocks and North Zone refers to the east and northeast sides of the deposit where all mineralization is hosted in sedimentary rocks.

Most of the drilling was with HQ-sized equipment with a lesser amount of NQ-sized core generated at the bottom of some of the deeper holes or where holes had to be reduced in size owing to poor ground conditions. Overall core recovery was excellent, generally exceeding 95%. Most holes were drilled vertically, although a certain number of angle holes were required, either where topographic problems dictated angled holes to reach specific areas or to better define possible vertical controls on mineralization. A few of the core holes were drilled using oriented core techniques to gather detailed structural information in support of pit slope investigations. Core recovery and Rock Quality Determination (RQD) measurements were obtained from the entire core, and once the core was photographed, it was

geologically described (petrography, alteration, and mineralization) prior to the core being sawed for assay. Logging was performed by a combination of Cambior and Luismin geologists using industry standard methods.

10.4 CHESAPEAKE DRILLING

Chesapeake initiated a drill program in December 2007, using two core rigs contracted from BDW Drilling de Mexico, S.A. de C.V. The primary purpose of the drill program was the twinning of a number of the older Cambior drill holes to generally validate the geology and assays of these older holes, and to bring these holes (and by analogy the rest of the Cambior drilling results) into compliance with NI 43-101 criteria, and thereby allow them to be used for future mineral resource estimation exercises. Secondary objectives were to generate sufficient sample for the preparation of new metallurgical composites, to drill several in-fill type holes between the Main and North Zones, and to drill several step-out holes to test the potential for expanding the area of known mineralization. In total, 14 twin holes totaling 4,763 m were drilled in the Main Zone, including three holes that were abandoned, while 7 twin holes totaling 2,997 m were drilled in the North Zone. In addition, a total of 8 in-fill type drill holes totaling 3,571 m were drilled between the North and Main Zones, along with 7 step-out holes totaling 3,084 m. In all, Chesapeake drilled a total of 36 holes totaling 14,379 m during its 2007–2008 drill campaign. Most of the holes were started using HQ-size equipment, but the holes were typically reduced in size to NQ below 100–150 m depth.

To ensure that the new twin drill holes had the best opportunity to accurately sample the same material as did the older Cambior holes, only vertical holes were drilled as part of the twin holes program. The collar locations of these holes were typically within a few meters of each other. Downhole surveys were performed on both the Cambior and the Chesapeake holes. Comparing the results of these downhole surveys indicates the bottom of the twin holes were generally within 10–15 m (or less) from the original hole, even for holes drilled to depths exceeding 400 m. All hole locations were chosen to minimize the amount of loose, unconsolidated talus and overburden, as this tended to cave in on the holes. Like the Cambior holes, the Chesapeake holes were logged for geology and RQD, photographed, and then sawed into halves for assay. The logging was performed to normal industry standards by Chesapeake geologists. Core recovery was also considered to be excellent with this program.

In February 2011, Chesapeake initiated a core drilling program using two drill machines contracted from Major Drilling de Mexico, S.A. de C.V. During 2011, 53 core holes amounting to 23,486 m of drilling were completed. Twelve holes totaling 3,219 m were oriented core and drilled for slope stability analyses conducted by Call & Nicholas, Inc. (CNI). The remaining drilling was infill and step out drilling, to upgrade the mineral resource model and provide samples for metallurgical testing.

An RC drilling program focused on condemnation was performed during 2012. These holes were assayed at nominal 3-m sample intervals with only a few scattered intervals returning anomalous results. As such, these holes were not used in the mineral resource estimate and are not included in Table 10-1.

The five holes drilled for the 2013 campaign were for the purpose of providing samples for metallurgical testing. The drilling and sampling procedures were the same as for the 2011 campaign. An additional five large diameter PQ-size core holes totaling 2,333 m were drilled in 2021 to support a column leach metallurgical testing program. The results of these holes have not yet been integrated into an updated mineral resource model.

Gold mineralization tends to dip about 40° to the northeast in the Main Zone (the southwest side of the deposit), and 40° to the southwest in the North Zone (northeast side). Figure 10-2 shows the gold mineralization on IMC Section 10 (local section 10,300E). As can be noted, vertical holes would tend to overstate true mineralization thickness by about 30%. The southwest-trending angle holes in the Main, or Intrusive-hosted, Zone would tend to show the true width of the gold mineralization.

Silver and zinc do not correlate well with gold mineralization as shown in Figure 10-3. In the North, or Sediment-hosted, Zone, the silver and zinc mineralization tends to be more flat lying, so vertical holes would measure almost true thickness. In the Main Zone, there is silver and zinc mineralization that corresponds to the intrusion, with the 40° northeast dip and also some near-surface mineralization that tends to be flat lying.

10.5 SAMPLING

10.5.1 General

The sampling data is from drill core or from a limited amount of RC drilling. Only the Cambior and Chesapeake drilling are used for the current mineral resource estimate used in this study. The area enclosed by the drilling is about 236 hectares and includes 229 of the 234 drillholes. This results in a geometric mean hole spacing of about 102 m. The geometric mean is the square root of the area divided by the square root of the number of holes.

10.5.2 Sample Lengths and Size

The sampling interval is consistently about 3 m for all samples. There is no evidence of any consistent attempts to break sample intervals at grade or lithologic boundaries.

For the Cambior 1993 drilling, core was continuously sampled at 3 m intervals in the intrusive and also within the sediments for 50 m from the intrusive-sediment contact. Beyond 50 m, assuming that the sediments were sterile looking, every tenth 3 m interval was sampled. If there was interesting mineralization assayed in the areas of the 1 in 10 samples submitted, the remaining core intervals were then submitted for assay.

In contrast to 1993, for the Cambior 1994-1995 drilling, all drill holes were sampled over their entire length. RC chip samples were taken on 10-foot intervals (3.05 m rod length) while core samples were taken at 3 m intervals.

Each 10-foot RC run produced approximately 130 to 180 kg of cuttings run through a cyclone and splitter. Six to twenty-five kilograms of sample were captured and bagged and sent to Bondar-Clegg Laboratories (BC Lab) and an equal amount bagged as a duplicate and stored on site.

Chesapeake core was also sampled on 3-m intervals. Drill core was transported from the drill rig to the secure logging and storage facility at the end of each twelve-hour drill shift. After the core was logged for geology and geotechnical attributes, the core was marked into three-meter sample intervals. The core was then photographed and sawn in half and one-half placed in a plastic sample bag marked with a unique sample number. The samples were shipped in a covered and secured truck to ALS Chemex Lab in Hermosillo, Mexico for the 2007-2008 drill campaign and to the ALS Chemex Lab in Zacatecas, Mexico for the 2011 core drill and 2012 RC drill campaign. The samples were shipped to the ALS Chemex Lab in Hermosillo for the 2013 drill campaign. For the 2021 large diameter core drilling campaign, all the prior routine logging and sampling protocols were followed except that a ¼ sawn sample was shipped to ALS in Zacatecas, Mexico. A ¼ portion of the core was to be archived at site and the remaining ½ core was to be shipped to the metallurgical lab. The results of the 2021 drilling have not been used to inform the current mineral resource model described in Section 14.

10.5.3 Conclusion

It is the opinion of IMC that the sampling method is appropriate for the nature of mineralization at Metates.

Core and RC recovery have been good for all the drilling programs. IMC does not anticipate any issues related to sampling due to sample recovery.

METATES SULPHIDE HEAP LEACH PROJECT - PHASE 1
FORM 43-101F1 TECHNICAL REPORT

The natural terrain at topography is quite steep in many places, which limits drill access in some cases. Several of the angled holes were drilled because it was not practical to locate a vertical hole in the desired area. However, most of the angled holes are orientated well for sampling Metates mineralization.

IMC does not know of any sampling or recovery factors that could materially impact the accuracy and reliability of results.

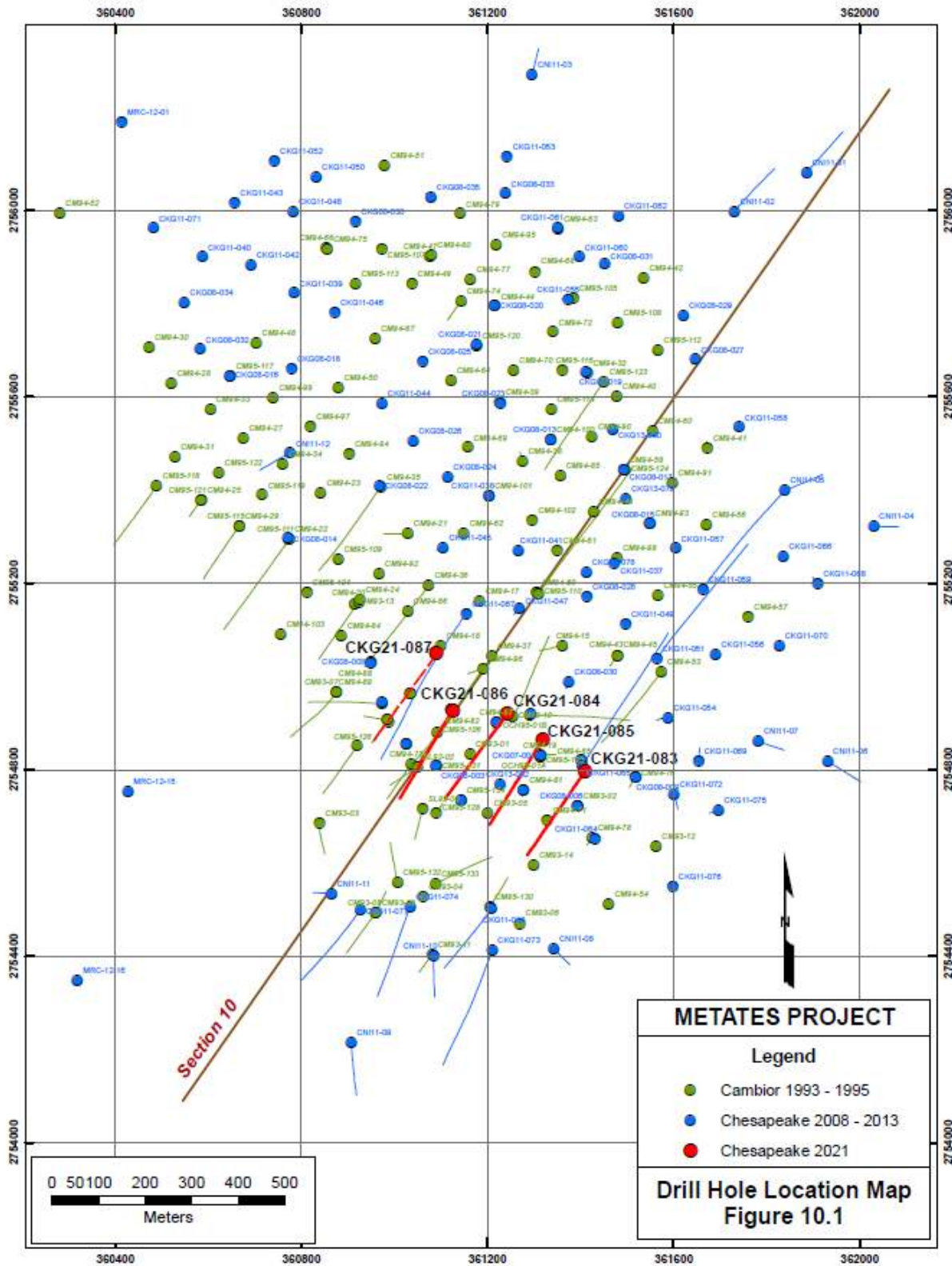

Figure 10-1: Drillhole Locations, Chesapeake 2021

METATES SULPHIDE HEAP LEACH PROJECT - PHASE 1
FORM 43-101F1 TECHNICAL REPORT

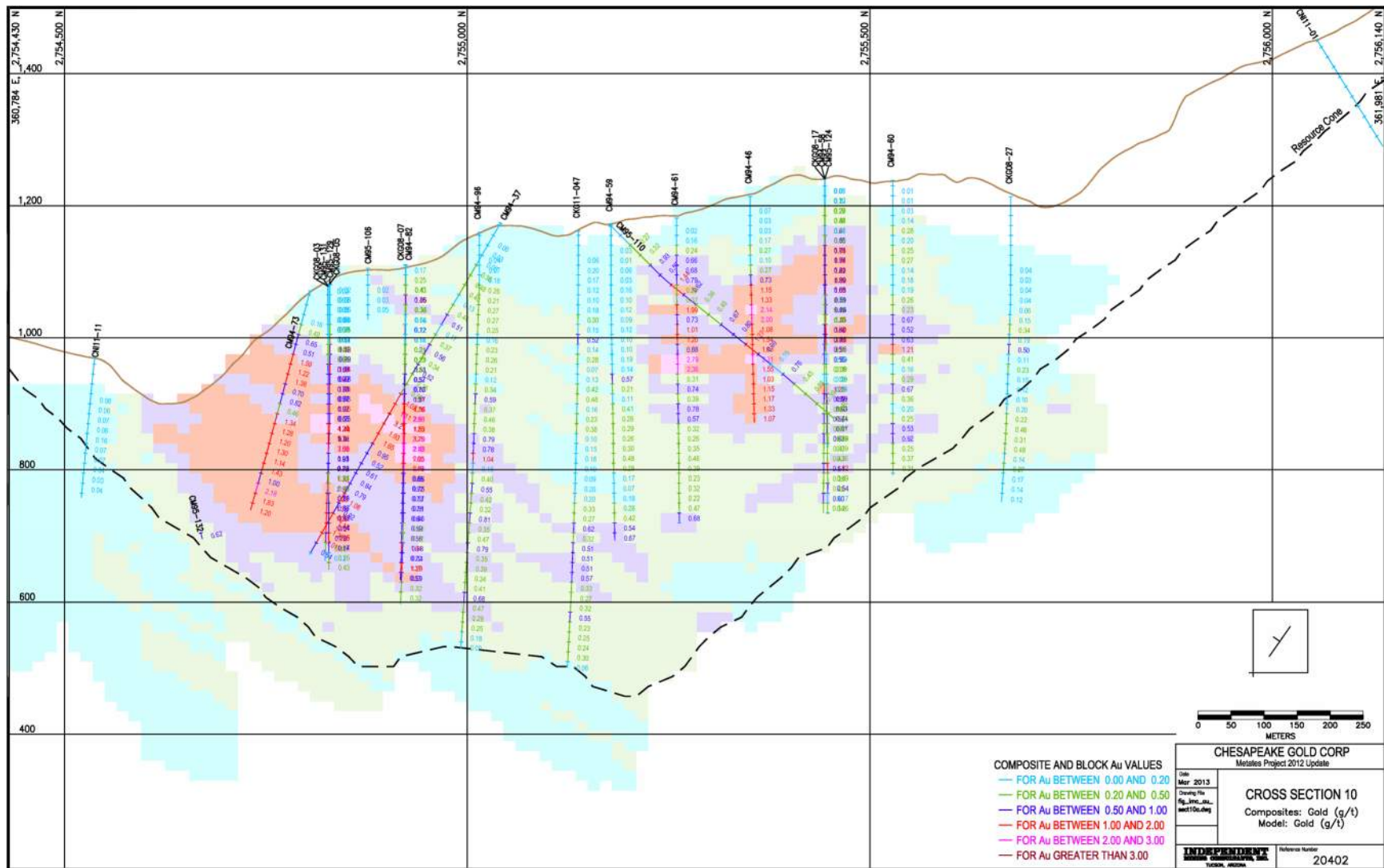

Figure 10-2: Gold Grades on IMC Section 10, IMC 2014

METATES SULPHIDE HEAP LEACH PROJECT - PHASE 1
FORM 43-101F1 TECHNICAL REPORT

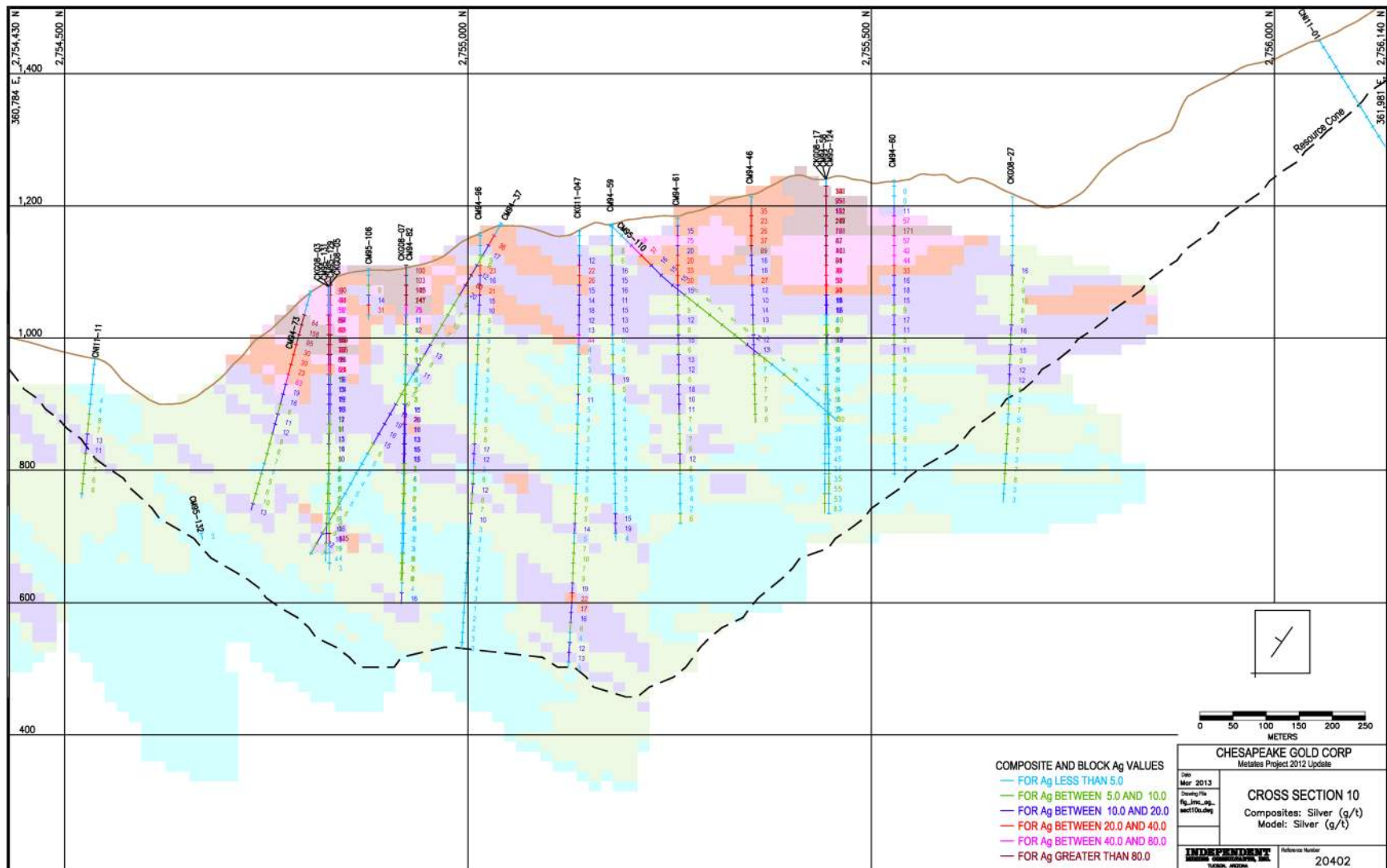

Figure 10-3: Silver Grades on IMC Section 10, IMC 2014

11 SAMPLE PREPARATION, ANALYSES AND SECURITY

11.1 CAMBIOR SAMPLES

For the Cambior drilling program, the sample preparation procedures and security protocols employed were commensurate with those generally employed on an industry-wide basis at that time. The drill core was regularly collected at the drill location and placed into wooden or plastic marked core boxes, and transported to a secure, covered area adjacent to the Metates camp for storage. At the storage area, the core was measured for geotechnical indicators and then photographed, and sample intervals were marked for sawing and bagging. One-half of the core was placed in marked bags, where they were subsequently stored in a covered and secure area. About once every week, or more often as needed, the accumulated bagged samples were transported to the Bondar-Clegg Laboratories (BC Lab) sample preparation lab in San Luis Potosi in a Cambior supplied truck. After sampling and logging, the core boxes were placed into storage in a covered and secure area. Subsequently, much of the core was used for compositing various metallurgical samples.

For the Cambior 1993 drilling, the samples were diamond-sawed and coarse-crushed by hand on-site. One half of this crushed half split was shipped to the BC Lab in Hermosillo, Mexico and/or Vancouver, Canada for pulverizing and assay/analysis. The remaining crushed material was kept on-site for possible metallurgical studies. Each sample was analyzed for gold, silver, copper, lead, zinc, molybdenum, arsenic, antimony, and mercury. The remaining half core was stored in covered areas on-site. There is no written description of the 1993 laboratory sample preparation procedures.

For the Cambior 1994–1995 drilling, core was diamond-sawed in half, except for a two-week period when a manual splitter was used. One half of the core was placed in bags labeled with the sample number and stored in a secure location on-site, until they were shipped on a company-owned truck to the BC Lab in San Luis Potosi for initial sample preparation. The remaining half core was returned to the core box and was kept on site in a secured covered area. The RC samples were dried on-site prior to shipping.

At San Luis Potosi, samples were oven-dried, weighed, and placed in new bags. Before each new work order/sample type was processed, 1 kg of sterile gravel was run through the crushers, commencing with a jaw crusher, which reduced the sample to 100% <1/2 inch, and further processed by an eccentric cone crusher, which crushed it to 100% <10 mesh. Each crusher was cleaned by compressed air between samples. When 75% or more of the sample passed through the #10 mesh, the sample was run through a separator and a 250 g sample was collected, and then sent to Vancouver for pulverization and analysis. Partway through the program, the reject amount collected for pulverization was increased to 1,000 g. A random check of 354 coarse rejects was passed through a #10 mesh sieve by Cone Geochemical (Cone) in Denver to check quality of grind. This study determined that 78% of the sample material sent to Vancouver was finer than #10 mesh.

Assaying for molybdenum and mercury was discontinued for the 1994–95 programs.

For both the 1993 and 1994–95 programs, BC Lab carried out gold assaying using fire assay with an atomic adsorption spectrophotometer (AA) finish. For a few holes early in the 1994–95 programs, a gravimetric finish was employed. Silver was assayed using both fire assay/AA finish and inductively-coupled plasma (ICP) techniques. The other elements were assayed using the ICP technique.

After the end of the 1994–95 drill programs, the coarse assay rejects in storage at San Luis Potosi were discarded, as well as any assay rejects stored in Hermosillo. In addition, the assay pulps in storage in Hermosillo were destroyed in a fire at the storage facility. The pulps in storage at the San Luis Potosi facility were also disposed of when this facility was closed in the late 1990's. Therefore, no drill assay rejects or assay pulps are available at the site or elsewhere in Mexico. The pulps that may have been in storage at the BC Lab facility in Vancouver and the Cone facility in Denver were also disposed of when these labs were closed.

Bondar-Clegg was a highly regarded analytical laboratory at the time the Cambior work was done. Bondar-Clegg was acquired by ALS Chemex Laboratories in December 2001. In addition, other than sawing of the core and the coarse crushing of the 1993 samples, the sample preparation and analytical work were not conducted by Cambior employees, officers, or directors.

11.2 CHESAPEAKE SAMPLES

The Chesapeake sample preparation procedures and security protocols employed were similar to those procedures described for the Cambior 1994–95 programs. Drill core was transported from the drill rig to the secure logging and storage facility at the end of each twelve-hour drill shift. After the core was logged for geology and geotechnical attributes, the core was marked into 3 m sample intervals. The core was photographed and then sawed in half, and one half placed in a plastic sample bag marked with a unique number. At the rate of about every 40th sample, one of the one-half core samples was cut in half to generate what is called a “1/4 core duplicate” sample, also with a unique sample number. Standards and blanks were introduced into the sample stream with unique sample numbers assigned at the rate of about 1 in 20 samples. The standards used are certified reference material sourced from an independent commercial third party. Three different analytical standards were used and cover a range of gold and silver values along with one blank standard to examine carryover contamination from sample to sample.

For the 2007-2008 drilling, samples were shipped in a covered and secured truck to ALS Chemex Laboratories in Hermosillo, Mexico. Once at the lab, the samples are dried, and the entire sample is crushed to 90% passing -10 mesh. Samples are then split, and a 1,000-g subsample is obtained, which is then pulverized to 85% passing -200 mesh in a ring-and-puck type mill. At the rate of about every 40th sample, a second 1,000-g split of the -10 mesh material is obtained and pulverized to generate a “preparation duplicate” sample, which is also assigned a unique number. At the rate of every 40th sample, the 1,000-g pulverized sample is split in two 500-g subsamples to create a “pulp duplicate” each of which is again assigned a unique sample number. Thus, for every 40th sample there are four separate assays reported for each sample interval. These four different assays performed on the four different assay pulps are instructive in determining the amount of sample variance related to each of these steps—core sampling, preparation, and pulverization (see Figure 11-1).

After pulverization, a portion of each of the individual pulp samples is shipped to the ALS Chemex Laboratories facility in Vancouver, BC, Canada, where the samples are analyzed as follows:

- For all samples: 0.25 g sample, 4 acid digestion with inductively coupled plasma-atomic emission spectroscopy (ICP-AES) finish for 27 elements including Ag, Zn, Cu, Mo, As, and S (Method ME-ICP61)
- For all samples: 30.0 g sample, fire assay with ICP-AES finish for low-level Au (Method Au-ICP21)
- For samples with Au > 2 g/t: 30 g sample, fire assay with gravimetric finish for Au (Method Au-GR21)
- For samples with Ag > 100 g/t: 30 g sample, fire assay with gravimetric finish for Ag (Method Ag-GR21)
- For samples with Zn > 10,000 ppm (1.0%): 0.25 g sample, 4 acid digestion with ICP finish (Method ZnOG62)

The assays were then reported to Chesapeake electronically and through signed assay certificates.

The same procedures were used for the 2011 drilling except sample preparation was done at the ALS Chemex laboratory in Zacatecas Mexico, instead of Hermosillo. Pulps were forwarded to the Vancouver laboratory for final analyses. For the short drill program in 2013 the samples were shipped to the ALS Chemex laboratory in Hermosillo,

with final analyses performed at their Vancouver laboratory and followed the same assay procedures as noted above. For the 2021 drilling, the routine sample size for Au fire assay was increased to 50 g from 30 g. In addition, all holes were also assayed for total and organic carbon and sulphide sulphur.

ALS Chemex laboratories are highly regarded facilities for sample preparation and analysis. Most laboratories are registered to ISO 9001:2000 standards, and many are ISO 17025 accredited. Chesapeake personnel were involved in neither sample preparation nor analytical analysis, other than sawing of the core.

11.3 CAMBIOR QA/QC PROGRAMS

As part of the 1993 drilling program, approximately 5,300 check assay pairs were run by five different laboratories as part of an "ad hoc" Quality Assurance/Quality Control (QA/QC) program. Some of the 1992 Luismin samples were included in this check assaying. In May 1994, the check assay data were reviewed by IMC which noted differences between assay means measured by different labs and methods. In most cases, these differences substantially exceeded the normally acceptable $\pm 5\%$ variance. Inter-lab mean assay differences generally increased on quarter split samples when only sedimentary samples were considered, and decreased when only intrusive samples were considered. IMC believed the "biases" were caused by on-site crushing and splitting procedures and laboratory biases, but Cambior believed there was no clear evidence that BC Lab assays were problematic, as there was a lack of consistency between the check assay laboratories. IMC recommended further study and stated that there were surely assay biases but did not quantify them or recommend application of a correction factor. In 1994, subsequent checking of 1993 data confirmed inter-lab bias but Cambior concluded that their metal content was not biased relative to the original core splits based on assays of core half splits remaining on-site. At the end of the 1994–95 QA/QC programs, prior to the receipt of another IMC study of assay bias, Cambior concluded that assay results from 1993 did not present any problems.

A systematic QA/QC program was begun early in the 1994–95 drill programs. In addition to the introduction of duplicates, blanks, and project-specific standards, all inserted about every 20 sample intervals, two angled holes were drilled in the North Zone to verify lateral continuity of precious metal values and evaluate potential structural controls, and three holes (including one RC hole) were twinned to evaluate reproducibility. Barringer Laboratories and Cone Geochemical Laboratories performed various check assay studies. In December 1995, IMC produced another report on the quality of assaying, this time quantifying the biases and recommending gold grade adjustments. IMC recommended that 1993 and 1994 gold assays be factored by 0.843 (0.887 analytical bias factor times 0.95 sample preparation bias factor) and 1995 gold assays be factored by 0.95 (sample preparation bias factor). An independent study was also conducted by Geostat Systems International Inc. (GSII). They also concluded that the Cambior gold assays were biased, though by a lesser amount, about 8%. GSII did not analyze the data by campaign. In spite of these studies, the Cambior preliminary feasibility study produced in 1997 did not apply any adjustments to the gold assay data.

11.4 CHESAPEAKE QA/QC PROGRAM

11.4.1 Chesapeake Drilling Data

Because of the various reports that identified a bias in Cambior assay results, Chesapeake developed an extensive QA/QC program to validate its own data and investigate and quantify the extent of the perceived bias in the Cambior data. Geochemical Applications International Inc. (GAIL) was retained as an independent contractor to set up the QA/QC program and analyze the results.

A description of the key QA/QC components of the program is as follows:

11.4.1.1 Sample Preparation

Core samples containing 3-m intervals of $\frac{1}{4}$ core were bagged and trucked to Hermosillo for the 2007-2008 drilling, to Zacatecas for the 2011 drilling, and back to Hermosillo for the 2013 drilling, where the samples were dried and jaw crushed to -10 mesh. The core samples for assay were delivered to Zacatecas for the 2021 drill program. A subsample of 1000 g was pulverized with LM-2 bowl pulverizers. Preparation (crusher) duplicates and analytical (pulp) duplicates (Figure 11-1) were split from the samples at crushing and pulverization phases of sample preparation, respectively. Certified reference materials (standards and blanks) were inserted into the sample stream.

11.4.1.2 Analytical Methods

ALS Chemex analyzed the samples for gold using 30-g fire assay digestion with an ICP finish (Method Au-ICP21). Silver and zinc were analyzed by 4 acid digestion with an ICP finish (Method ME-ICP61). Check analyses were conducted at Acme Laboratories (Acme) on pulp samples using a 30-g fire assay digestion with an ICP finish for gold (Acme Method G6) and 4 acid digestion with an ICP finish for silver and zinc (Acme Method 1E).

11.4.1.3 Reference Materials

Five certified reference materials were used in the 2007–2008 drill programs. Standards GS-2B, GS-2C, SE-1, SE-2, and a blank (BL-3) were purchased from Canadian Resource Laboratories Ltd. in Delta, B.C. The blank is barren of gold and silver, but weakly mineralized for zinc.

Three certified reference materials were used in the 2011 and 2013 drill programs. Standards CDN-GS-P7B, CDN-ME-12, and a blank (BL-7) were purchased from Canadian Resource Laboratories Ltd. These same standards were used for the 2021 drilling program.

11.4.1.4 Duplicates Sampling

Duplicate samples are used to evaluate the greatest source of variation within a sampling scheme. Precision (or reproducibility) is measured using duplicates that are taken routinely through the resource drilling stage at every step, where the sample is reduced in size and sub-sampled before analysis. At least three kinds of duplicates are required to estimate the precision and, hence, the sampling risk on a resource. These types of duplicates are illustrated in Figure 11-1. In the Metates drilling program, sample reproducibility was measured with analyses of $\frac{1}{4}$ core sample duplicates. Preparation reproducibility was measured with duplicate crush splits collected after crushing the sample. Analytical reproducibility was measured by analysis of duplicate pulp splits collected after pulverizing the sample.

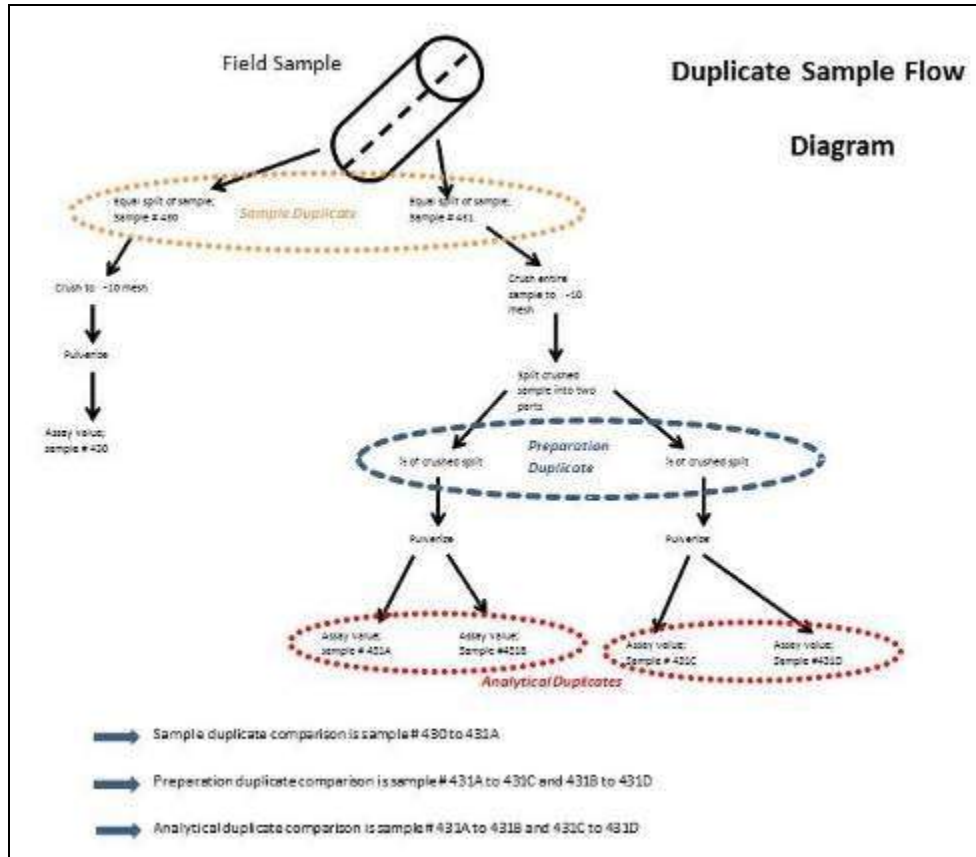

Figure 11-1: Duplicates Sampling Scheme, GAI 2009

11.4.1.5 Conclusions

The QA/QC program implemented during the 2007–2008 exploration program used standards and blanks, as well as sample duplicates, preparation duplicates, and analytical duplicates included into the sample stream. Over 6,000 samples were analyzed at ALS Chemex with 400 determinations performed on certified standards. Approximately 100 sample duplicates, 240 preparation duplicates, and 240 analytical duplicates were used to monitor reproducibility at each level of sample preparation and analyses. A total of 380 samples were sent to Acme for check analyses.

Drilling during 2011 resulted in about 6,674 additional samples that were analyzed at ALS Chemex. Determinations on certified standards amounted to 371 assays for gold and silver and 186 assays for zinc. There were 186 blanks ran for gold, silver, and zinc and approximately 186 sample duplicates, 368 preparation duplicates, and 368 analytical duplicates were also used to monitor reproducibility. A total of 511 sample pulps, mostly the sample and preparation duplicates, were sent to Acme in Vancouver for check assays. No formal review of the QA/QC program for the 2013 drill program was undertaken owing to the limited extent of that program, but the same protocols were followed as for the 2007-2008 and 2011 programs. As with the 2013 program, no formal review of the 2021 drilling program is anticipated owing to its limited extent.

ALS Chemex analyzed the samples for gold using 30 g fire assay digestion with an ICP finish (Method Au-ICP21). Silver and zinc were analyzed by 4 acid digestions with an ICP finish (Method ME-ICP61). Check analyses were conducted at Acme on pulp samples using a 30 g fire assay digestion with an ICP finish for gold (Acme Method G6) and 4 acid digestion with an ICP finish for silver and zinc (Acme Method 1E).

Standards

Overall accuracy is within acceptable limits for gold, silver, and zinc using the Au-ICP21 and ME-MS-41 analytical methods at ALS Chemex and indicates that these analyses are suitable for mineral resource estimation.

Duplicates

Duplicates generally show good agreement between the assay pairs. Sample duplicates show acceptable precision at concentrations above 0.4 ppm gold, 5 ppm silver, and 2000 ppm zinc. This situation improves with preparation of the sample as it undergoes blending and homogenization with each phase of sample reduction and sub-sampling. A representative sample after the crushing sample preparation phase may be obtained down to gold concentrations of 0.20 ppm, silver concentrations of 5 ppm, and zinc concentrations of 500 ppm. Analytical reproducibility improves significantly relative to preparation duplicates reproducibility. Means and standard deviations show no statistically significant difference between original and duplicate analyses. All duplicate types are highly correlated and lack any significant bias.

Check Analyses

ALS Chemex and Acme check analyses exhibit acceptable reproducibility for gold concentrations greater than 0.4 ppm, silver concentrations greater than 8 ppm, and zinc concentrations greater than 150 ppm. Comparison of standard analyses by both laboratories indicates acceptable accuracy for all analytical methods used during the Metates exploration drill program, and no significant analytical bias between the original and check labs for gold, silver and zinc. Acme analyses validate the earlier analyses obtained by ALS Chemex.

11.5 REVIEW OF CAMBIOR DRILLING AND QA/QC DATA

Chesapeake also retained GAll to conduct a comprehensive review of the Cambior data and the IMC work done for the 1993–1995 drilling programs. GAll was asked to review the results of these studies and to determine if:

1. An analytical bias existed in the 1994 Bondar-Clegg gold analyses.
2. The 1993 gold assays were biased to the same degree as the 1994 gold assays.
3. There was a preparation bias that should be applied to all 1993–1995 Bondar-Clegg assays.
4. The magnitude of these biases could be validated and reproduced.
5. The IMC correction was reasonable, given the current understanding of the sample preparation and analysis methods.
6. There is a more robust method to determine these corrections.

This review reproduces the IMC efforts and includes:

1. Reviewing the reports written by IMC
2. Obtaining the original check analysis database from IMC and validating that data against the number of check analysis pairs used in the IMC calculations
3. Reviewing the bias correction protocols
4. Regenerating the control plots
5. Verification of all bias calculations
6. Determination of the correction factor for these biases

7. Examination of alternative correction factor methods

The conclusions reached by GAI are as follows:

1. There is a 10.15% analytical bias in the 1994 Bondar-Clegg gold analyses. This bias is systematic and can therefore be corrected by applying a correction factor of 0.8985 to the 1994 Bondar-Clegg gold analyses.
2. There is no information available to change IMC's conclusion that the 1993 Bondar-Clegg gold assays have the same analytical bias as the 1994 Bondar-Clegg gold assays.
3. There is no significant preparation bias which could affect three years of Bondar-Clegg gold analyses. This source of error would have introduced gold into the samples during sample pulverization at the Bondar-Clegg preparation facility across a period of three years. All of the data comparison scatter plots show that the sample preparation error (or bias) is random and not systematic. IMC's method of evaluation for this component of error incorporates and mixes sample preparation and analytical error and is influenced by the analytical bias observed in the 1994 Bondar-Clegg gold assays.
4. Outliers dramatically influence the determination of bias. Using weighted least-squares regression provides a robust method for determining a correction factor to be applied the analytical biased data. This method incorporates systematic and random error, using the precision of duplicate pairs to weight the regression to determine the slope-based correction factor. This method is far less sensitive to the influence of outlier samples than previously used estimation techniques.
5. GAI has revised the 1995 IMC correction factors based upon this review; these are listed in Table 11-1. The analytical bias of 10.15% in the 1993 and 1994 Bondar-Clegg gold assays can be corrected by applying a correction factor of 0.8985. The 1995 Bondar-Clegg gold analyses require no correction.

Table 11-1: GAI Recommended Gold Adjustments

Metal	Year	No. Assays	Analytical	Preparation	Combined
Gold	1993	1,200	0.8985	None	0.8985
Gold	1994	10,400	0.8985	None	0.8985
Gold	1995	3,200	None	None	None

11.6 CONCLUSIONS

It is the opinion of the authors that the sample preparation and analytical procedures employed by Cambior and Chesapeake are adequate for the purpose of defining mineral resources and mineral reserves. The Cambior QA/QC procedures identified, at least to the satisfaction of some of the independent reviewers, that there was an assay bias in the 1994 data. The Chesapeake QA/QC work has verified the bias and quantified the likely impact. Cambior's 1993 and 1994 gold assays have been factored by 0.8985 to correct for an apparent analytical bias at the Bondar-Clegg laboratory.

12 DATA VERIFICATION

IMC conducted much of the work to assemble the Cambior drilling database for their 1997 preliminary feasibility study and still has the original database in its archives. IMC compared this archive data with the assay database provided by Chesapeake at the start of the 2009 mineral resource modeling work. The comparison validates that the original data has not been tampered with nor otherwise altered since the Cambior study.

IMC also compared the Chesapeake assays in the database with the ALS Chemex assay certificates to verify the 2007-2008 drilling data. For 2011 drilling, IMC compared the database entries with assay certificates for five holes, about 10% of the new data. No errors were encountered. IMC considers that the 2011 drilling data is verified.

The five holes drilled for the 2013 program were composited to 15 m bench composites and compared with the 2012 mineral resource model. On a hole-by-hole basis the comparisons are quite variable, but the five holes as a group compared reasonably well with the model for gold and silver. This implies the holes compare reasonably well with the other holes in the vicinity.

The five holes drilled in the limited program in 2021 are all inclined holes and are not twins and targeted the intrusive-hosted mineralization. These holes confirmed the as modeled rock types, contact depths and extent of mineralization. On a gold equivalent basis, the several assay results from the 2021 holes were markedly higher than the comparable block model grades in the current mineral resource model.

During the 2007-2008 drilling campaign, Chesapeake drilled a total of 14 twin holes in the Main Zone, including three holes that were abandoned, for a total of 4,763 m along with 7 holes drilled in the North Zone for a total of 2,997 m. Twin holes were drilled into both zones to ensure that information was gathered from both mineralized environments. The holes were generally placed within 1 or 2 m from the identified collar locations of the original Cambior drillholes. To ensure that the twin holes had the best chance of tracking close to the original holes, only vertical holes were selected to be part of the twin program. Down hole surveys were performed for both the original Cambior holes and the Chesapeake holes, and the results of the surveys were compared to determine how far apart the holes were at various depths. For the 18 twin holes, the average horizontal separation at the bottom of the twin hole as compared to the original hole was 8.5 m.

The assay results for the twin holes program are summarized in Table 12-1; they compare the weighted mean grades for the twin holes for both the Main and North Zones for gold, silver, and zinc grades. The silver grades compare well to each other for the twin and original holes for both the Main and North Zones. The zinc grades are slightly higher for the twin holes from both zones, which could be related to a slightly different assay protocol employed with the new assays for the twin holes. The gold grades between the original and twin holes for the North Zone are also quite close, and difference between the two sets of assays are not statistically significant. The gold grades for the twin holes from the Main Zone support the overall grades for the original holes but are lower. This is likely related to the assay bias issue for gold noted in Section 11.

The twin holes study further validates the general results of the Cambior drilling.

Table 12-1: Assay Summary of Chesapeake/Cambior Twin Holes

Metal	Zone	Holes	Assay Intervals (m)	Mean Original	Mean Twin
Gold	Main Zone	11	1,192	0.87 g/t	0.71 g/t
	North Zone	7	1,081	0.58 g/t	0.53 g/t
Silver	Main Zone	11	1,221	19.4 g/t	18.6 g/t
	North Zone	7	1,118	16.8 g/t	17.4 g/t
Zinc	Main Zone	11	1,221	0.23%	0.26%
	North Zone	7	1,119	0.12%	0.13%

Also, as discussed in Section 11, Geochemical Applications International Inc. (GAI) conducted a significant amount of work to validate the Metates assay database during 2009.

It is the opinion of IMC that the Metates drilling database is adequate for mineral resource and mineral reserve estimation.

13 MINERAL PROCESSING AND METALLURGICAL TESTING

In this section, the term “ore” is used to distinguish “whole ore” from flotation concentrates, only for the sake of clarity. It is not meant to indicate economic viability of the material to mining and processing.

Gold and silver in the Metates deposit are refractory due to encapsulation by sulphides namely pyrite, arsenian pyrite and arsenopyrite as described in more detail in Section 7. Various oxidation schemes have been tested in the past, including bacterial oxidation, roasting, oxidation under ambient conditions, and pressure oxidation (POX) of sulphide concentrates (Austin et al., 2016). The results show that gold and silver recoveries by cyanidation improve linearly with the degree of oxidation. Figure 13-1 below presents gold recovery from sulphide concentrates as a function of the degree of oxidation.

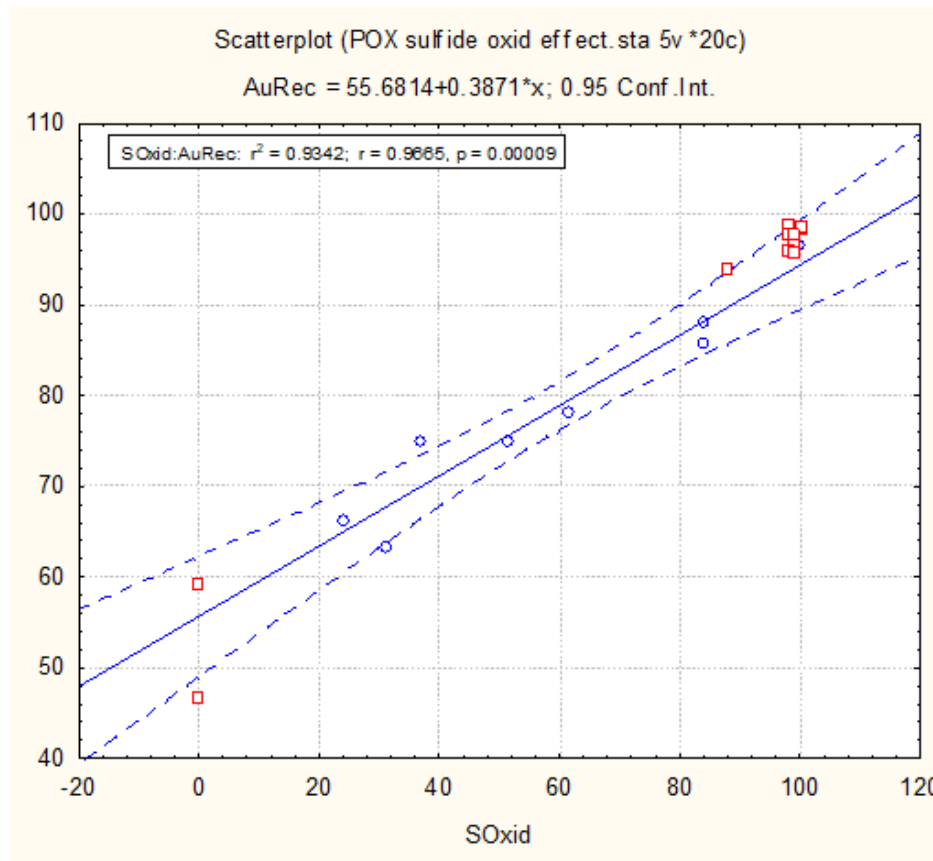

Figure 13-1: Recovery vs Degree of Oxidation (red squares from POX tests in 2013)

While pressure oxidation resulted in high metal recoveries, the initial capital required to build a flotation plant and POX plant is high. This study explores the applicability of a two-stage heap leaching process, where “whole ore” material is oxidized first on an on-off pad and then cyanide leached on a dedicated pad.

Chesapeake Gold has contracted Kemetco Research Inc. (Kemetco) in Richmond, British Columbia to perform a comprehensive column leach testing program on composites and variability samples from Metates. Bench-top agitated oxidation and leach tests have been started. A few of these tests have been completed on sample composites from core drilled in 2007-2008, and the results are presented in this report. Two 8-ft columns were started as sighter tests on two composites, which represent the two material types in the orebody, to test and refine the column leach testing

procedures to be employed in the comprehensive testing program. The sighter column tests are being conducted on composites that were prepared about 7 years prior to this report.

The comprehensive testing program will involve newly collected samples from five PQ-sized core drill holes that were drilled early in 2021. The main focus of the comprehensive testing program will be intrusive and intrusive breccia materials. The drilling program also intercepted sedimentary intervals. These will also be subsequently tested to establish baseline behavior for possible future testing to deal with potential preg-borrowing behavior. Preg-borrowing is the phenomenon whereby constituents of the “whole ore,” in this case sedimentary carbon, remove gold cyanide complex from solution making it unavailable for adsorption on the granulated activated carbon added for process gold recovery.

13.1 PREVIOUS METALLURGICAL TESTING

Previously, Chesapeake generated a total of 49 metallurgical composites totaling 6,198 kg from 21 drill holes representing 4,598 m of drill core obtained from the 2007-2008 drill program. Portions of these composites were used to generate two master metallurgical composites for further in-depth study reserving portions of the remaining drill core composites for additional testing as variability samples. Chesapeake sent two master composite samples to Resource Development Inc. (RDi) in Wheat Ridge, CO for testing. They were designated as Intrusive Composite and Sedimentary Composite. The Intrusive Composite consisted mostly of massive intrusive quartz latite with lesser amounts of intrusive-related breccia. The Sedimentary Composite comprised several sedimentary rock types (sandstone, shale), with arenite or sandstone being the most prevalent.

The head analyses of the composite samples are given in Table 13-1. The chemical analyses for the composites show that there may be potential for by-product lead and zinc.

Table 13-1: Head Assays of Composite Samples

Element	Au, g/t	Ag, g/t	Pb, ppm	Zn, ppm	C _{ORG.} %	S _{TOTAL} %	S _{SULPHIDE} %
Intrusive	0.98	9.67	436	1970	0.36	6.87	6.83
Sedimentary	1.00	28.62	488	1890	0.47	4.35	4.26

*Back calculated from 24 tests on intrusive and 25 tests on sedimentary

13.1.1 Comminution Indices

Comminution parameters determined during prior studies for the intrusive and sedimentary material samples are shown in Table 13-2.

Table 13-2: Measured Comminution Parameters for Metates Composites (by Hazen)

Comminution Parameter	Sample or Composite	
	Intrusive	Sedimentary
CW _i , kWh/t	13.2	15.7
RW _i , kWh/t	16.7	16.4
BW _i (100 mesh), kWh/t	13.3	12.3
Abrasion Index, A _i , grams	0.052	0.041

13.1.2 Leach Tests on Non-Oxidized Samples

About half of the gold and three fifths of the silver in the Metates “whole ore” is refractory to cyanide leaching. Table 13-3 below shows the average recovery of gold and silver from intrusive and sedimentary samples of “whole ore”, as well as from flotation concentrates performed on samples generated from core drilled during 2007-2008. The table shows the low gold and silver recoveries of untreated “whole ore” or flotation concentrate. The significant improvement

of gold recovery in the carbon-in-leach (CIL) tests also indicate potential preg-borrowing in the sedimentary “whole ore”.

Table 13-3: Bottle Roll and Agitation Leach Tests on “Whole Ore” Samples and Rougher Flotation Concentrates

Bottle Roll Leach Tests, “Whole Ore”, P₈₀ = 100 microns, 96 hours				
<i>Direct Cyanidation - 96 hours</i>	Intrusive		Sedimentary	
	Au	Ag	Au	Ag
Extraction %	52.7	28.5	9.0	32.6
Residue g/t	0.41	8.28	0.62	19.32
Calc. Head g/t	0.86	11.58	0.68	28.66
<i>Carbon-In-Leach (CIL) - 96 hours</i>	Intrusive		Sedimentary	
	Au	Ag	Au	Ag
Extraction %	47.6	25.1	49.0	39.7
Residue g/t	0.49	11.61	0.37	15.38
Calc. Head g/t	0.93	15.49	0.73	25.52

Agitation CIL Tests, Rougher Flotation Concentrate, P₈₀ = 212 microns, 48 hours				
<i>Carbon-In-Leach - 48 hours</i>	Intrusive		Sedimentary	
	Au	Ag	Au	Ag
Extraction %	57.3	43.6	37.3	39.7
Residue g/t	2.06	23.83	3.36	110.74
Calc. Head g/t	4.82	42.24	5.36	183.68

The insoluble gold and silver are believed to be encapsulated in pyrite, arsenian pyrite and arsenopyrite. The sulphides need to be oxidized to liberate the encapsulated values to achieve economic recoveries.

13.2 CURRENT METALLURGICAL TESTING

A comprehensive testing program has been developed to determine the operating parameters for the planned heap leach operations at Metates. This includes preliminary baseline agitated leach and column leach tests on older samples to establish the baseline recoveries of gold and silver from intrusive and sedimentary sample composites. Baseline agitated oxidation tests on ground materials are also included to establish the amenability of the materials to oxidation. A comprehensive series of column leach tests will be performed on intrusive and sedimentary composites generated in the 2021 core drilling program to determine oxidation chemical conditions, oxidation times and crush size.

The degree of oxidation will be determined from sulphide sulphur assays of solids before and after oxidation. During the tests, the degree of oxidation will be monitored and estimated by the total sulphur in solution, either sampled from agitated tests, or collected from the column tests.

13.2.1 Agitated Oxidation and Leach Tests

Intrusive material from the 2007-2008 drilling was used to make up a composite sample to determine the amenability of “whole ore” to oxidation in an agitated alkaline system with aeration. The intrusive composite was ground to a P₈₀ of 74 microns, oxidized in an aerated and agitated vessel. The samples were leached with cyanide in agitated and aerated vessels. The results of the bench-top tests are shown in Table 13-4.

The cyanide soluble gold and silver in the intrusive composite are in line with previous observations from “whole-ore” and concentrates. After oxidation to 47%, gold (Au) and silver (Ag) recoveries increased to 83% and 82%, respectively. These quick tests indicate that intrusive samples can be oxidized in alkaline environment under atmospheric conditions.

Table 13-4: Baseline Oxidation and Leach Tests on Intrusive Composite Materials

Agitated Leach Tests, “Whole Ore”, P ₈₀ = 74 microns, 48 hours						
Sulphide Sulphur Oxidation, %	Unoxidized		18.4%		46.8%	
	Au	Ag	Au	Ag	Au	Ag
Extraction, %	64.6	48.5	53.5	68.1	82.8	82.2
Residue, g/t	0.31	6.97	0.45	2.85	0.15	1.84
Head, g/t	0.87	13.4	0.87	13.4	0.87	13.4

While sedimentary materials are currently not slated to be processed as part of this study, their oxidation and leaching behavior are also being tested for future consideration. Initial results for a sedimentary composite made from the 2007-2008 drilling are similar to previous tests, showing improved cyanidation recovery in the presence of activated carbon. Oxidation to 46% improved gold recovery from 37% to 60% in CIL tests, as shown in Table 13-5.

Table 13-5: Baseline Oxidation and Leach Tests on the Sedimentary Composite Materials

Agitated Leach Tests, Oxidized “Whole Ore”, P ₈₀ = 74 microns, 48 hours						
	Sedimentary, Base		Sedimentary, Test 1		Sedimentary, Test 2	
Oxidation, %	Unoxidized		38.7		46.1	
<i>Direct Cyanidation - 48 hours</i>	Au	Ag	Au	Ag	Au	Ag
Extraction, %	12.9	43.1	9.5	42.3	12.6	54.5
Residue, g/t	0.29	6.65	0.36	7.79	0.33	5.71
Calc. Head, g/t	0.33	11.6	0.37	13.1	0.36	12.63
<i>Carbon-In-Leach (CIL) - 48hours</i>	Au	Ag	Au	Ag	Au	Ag
Extraction, %	36.6	37.3	53.3	44.1	59.6	56.0
Residue, g/t	0.23	7.98	0.18	7.67	0.18	5.28
Calc. Head, g/t	0.36	12.63	0.36	12.63	0.36	12.63

13.2.2 Column Oxidation and Leach Sighter Tests

Column oxidation and leach tests are being conducted on the same intrusive and sedimentary composite materials used for the agitated oxidation and leach tests noted in Table 13-4 and Table 13-5, above. These tests will be use 6-inch diameter by 8-foot columns made of polycarbonate plastic. During the oxidation phase, alkaline solution is introduced at the top of the column at a rate of about 1 liter per day. Air is injected at the bottom of the column to provide oxygen to the oxidation reaction. The composite being tested was crushed to a nominal P₈₀ of 13 mm.

Figure 13-2 includes four pictures of the intrusive column from May 18, 2021 (start of the test) to August 11, 2021. The series of pictures shows how the composite changed in color over time from gray to yellow-brown as it is being oxidized.

The degree of oxidation is being monitored by the total sulphur collected in the solutions every day. Correction was made for the initial sulfate content of the composite that reported with the sulphur going into solution due to oxidation. The actual degree of oxidation will be determined from sulphide sulphur assays of solids before and after oxidation.



Figure 13-2: Column of Intrusive Composite Sample Under Oxidation

13.3 2021 METALLURGICAL DRILLING

Chesapeake drilled five PQ-sized diamond core drill holes to provide samples of sedimentary, intrusive breccia, and massive intrusive materials for the comprehensive column oxidation and leach tests to be performed at Kemetco. Table 13-6 presents pertinent information on the diamond drilling program.

Table 13-6: PQ Diamond Core Drilling and Samples for Metallurgical Composites

Hole_ID	CKG21-083	CKG21-084	CKG21-085	CKG21-086	CKG21-087
Easting	361409	361242	361318	361125	361093
Northing	2754795	2754918	2754863	2754925	2755060
Elevation, m	1045	1066	1069	1097	1146
Hole Depth, m	426	471	456	479	501
Sedimentary Composite # Samples	12	14	10	11	13
Sedimentary Composite grade, g/t AuEq	1.03	0.94	0.98	1.14	0.70
Intrusive Breccia # Samples	6	10	14	23	7
Intrusive Breccia grade, g/t AuEq	0.83	0.98	0.97	1.41	1.15
Massive Intrusive # Samples	5	17	21	4	13
Massive Intrusive grade, g/t AuEq	1.18	1.07	1.50	1.04	1.25

The 2021 drill hole locations are shown in Figure 13-3, superimposed on previous drilling done on the property.

METATES SULPHIDE HEAP LEACH PROJECT - PHASE 1
FORM 43-101F1 TECHNICAL REPORT

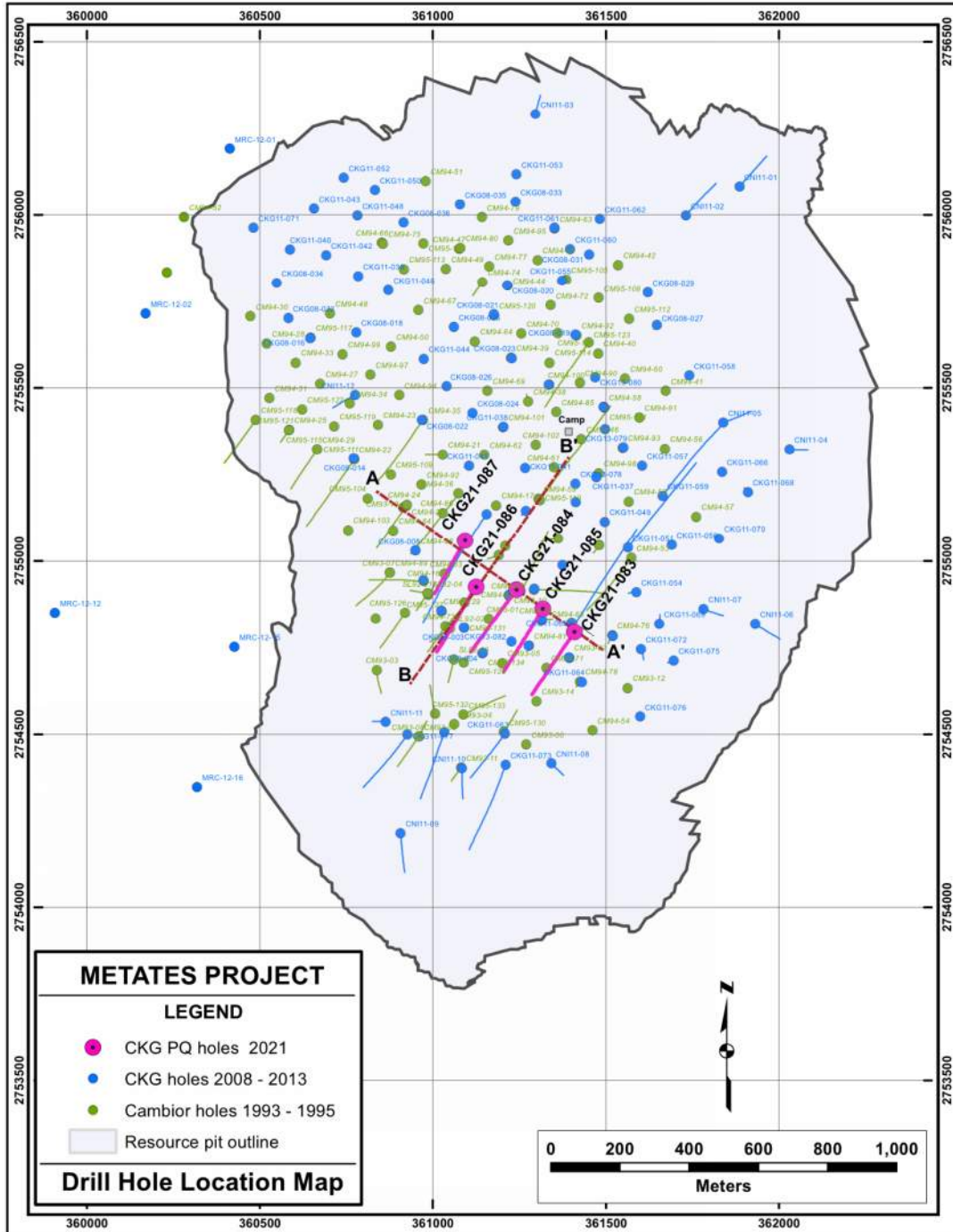

Figure 13-3: Location of Five Metallurgical Drill Holes Relative to Previous Drilling, Chesapeake 2021

13.4 METALLURGICAL TESTING PLAN

The focus of the comprehensive testing program to be performed at Kemetco is intrusive material followed by intrusive breccia material. Sedimentary materials, which are not currently in scope of this study, will also be subjected to a limited number of tests to establish the effect of potential preg-borrowing.

Drill core samples from the 2021 PQ diamond drilling have been split as follows: ½ core for metallurgical testing, ¼ core for assaying, and ¼ core to the core shed. The metallurgical splits have been bagged in three-meter intervals, with each bag labelled with the borehole ID, meterage, and weight. In the laboratory, three composites will be assembled to represent intrusive, intrusive breccia, and sedimentary materials. Each composite will comprise less than half of the total mass of each material type. The remaining materials not used for compositing will be kept at site for future variability testing.

Baseline tests will include agitated oxidation and leach tests on ground composites (74 microns) and column leach tests on unoxidized composites at ½-inch crush.

A series of column leach tests will comprise the main body of the testwork. Column oxidation tests will be conducted using a range of oxidation times from 60 days to 180 days at ½-inch crush. These tests aim to establish oxidation kinetics for each material type. Column oxidation tests will also be conducted at 1-inch crush at a chosen oxidation time to determine the effect of crush size. All columns will then be subjected to standard column leach testing using cyanide solution.

13.5 GOLD AND SILVER RECOVERIES

Chesapeake is targeting recoveries of 70% Au and 75% Ag for massive intrusive and intrusive breccia materials, based on previous metallurgical testing and current baseline testing. To attain these recoveries, the estimated degree of sulphide sulphur oxidation would need to range from 30 to 50%, depending on sulphide sulphur content and mineralogy of the materials.

13.6 OTHER METALLURGICAL TESTS

RD_i performed a few other tests to explore various alternative processing options. Ultimately, these were not recommended as viable for the Metates "whole ore." Details of these tests can be found in the RD_i metallurgical report (RD_i, 2010; 2012a; and 2012b). They include differential Pb/Zn/FeS₂ flotation, carbon pre-float, cleaner flotation tests, gravity flotation testing of rougher concentrate and leach of gravity concentrate, fine grinding of rougher concentrate and leach, and leaching of roasted rougher concentrate.

Low gold and silver recoveries from cyanide leached residues following roasting tests conducted by Hazen steered the processing investigations away from roasting. Details of the roasting tests can be found in Hazen's final reports (Hazen Research, 2010a).

Flotation concentrate samples were also tested using the Albion process (Core Resources, 2009 and Core Metallurgy 2020) and FLSmidth's Rapid Oxidative Leach (ROL) process (FLSmidth, 2020). Both show potential to improve recoveries after oxidation using limestone as the main neutralizer. Both schemes may be explored in the future if construction of a mill becomes a viable option.

14 MINERAL RESOURCE ESTIMATES

14.1 MINERAL RESOURCE

The mineral resources are based on a block model developed by IMC during July 2014 and included in the 2016 technical report. The 2021 drilling for metallurgical samples was not incorporated into this study. The resource block model will be updated with this new information prior to conducting a Preliminary Feasibility Study.

Table 14-1 presents the mineral resource estimate for the Metates Project. Measured and indicated mineral resource amounts to 1.30 billion tonnes at 0.47 g/t gold and 12.9 g/t silver for 19.8 million ounces of contained gold and 542.0 million ounces of contained silver. Inferred mineral resource is an additional 62.2 million tonnes at 0.32 g/t gold and 9.0 g/t silver for 640,000 ounces contained gold and 18.0 million ounces of contained silver.

The mineral resource is broadly divided into mineral resources that are intrusive hosted and mineral resources that are sediment hosted. In terms of measured and indicated mineral resource tonnes, about 80% of the mineral resources are sediment hosted and 20% intrusive hosted. Due to higher gold grade, the intrusive hosted mineral resources account for 27% of the contained gold ounces.

The measured, indicated, and inferred mineral resources reported herein are contained within a floating cone pit shell, shown in Figure 14-1, and are compliant with the “reasonable prospects for economic extraction” clauses of the Canadian NI 43-101 regulations. The mineral resource cone shell is based on a gold price of US\$1600 per ounce and a silver price of US\$20 per ounce. Table 14-2 shows the economic and metal recovery parameters used to develop the pit shell and cut-off grade. The mining cost estimate is based on conventional open pit mining. The processing costs and recovery estimates are based on a two-stage metallurgical process. First, the leach resource is crushed and placed on a temporary (“on-off”) pad and treated to oxidize the sulphide mineralization. After oxidation, the resource is then transferred to a permanent leach pad for conventional cyanide leaching. The G&A cost is based on administrative costs of US\$11 million per year and a process production rate of 30,000 tonnes per day or about 11 Mt per year. The mineral resource estimate assumes an eventual larger project than is currently described in Section 16.

The mineral resources are based on an equivalent gold cut-off grade of 0.26 g/t where:

$$\text{Gold Equivalent} = \text{Gold} + \text{Silver} / 74.67$$

The gold equivalent calculation accounts for all the relevant price and recovery parameters. Measured, indicated, and inferred mineral resources were allowed to contribute to the economics for the mineral resource cone shell.

Slope angles for the mineral resource cone shell were developed by Call & Nicholas, Inc. (CNI) of Tucson, Arizona and are reported in “Prefeasibility Slope Angles for Metates Deposit,” dated December 2012. Section 16.2 describes the angles used by domain.

Table 14-1: Mineral Resource

Mineral Resource Category	Mtonnes	Gold Eq. (g/t)	Gold (g/t)	Silver (g/t)	Gold (moz)	Silver (moz)
Measured Mineral Resource	395.4	0.79	0.59	15.5	7.44	197.3
<i>Intrusive Host</i>	103.1	0.98	0.76	16.5	2.52	54.6
<i>Sediment Host</i>	292.4	0.73	0.52	15.2	4.92	142.7
Indicated Mineral Resource	907.0	0.58	0.42	11.8	12.36	344.7
<i>Intrusive Host</i>	146.0	0.76	0.60	11.9	2.79	55.9
<i>Sediment Host</i>	761.1	0.55	0.39	11.8	9.57	288.7
Measured/Indicated Resource	1,302.4	0.65	0.47	12.9	19.80	542.0
<i>Intrusive Host</i>	249.0	0.85	0.66	13.8	5.32	110.6
<i>Sediment Host</i>	1,053.4	0.60	0.43	12.7	14.48	431.4
Inferred Mineral Resource	62.2	0.44	0.32	9.0	0.64	18.0
<i>Intrusive Host</i>	3.4	0.51	0.43	6.0	0.05	0.7
<i>Sediment Host</i>	58.8	0.44	0.32	9.2	0.60	17.3

Notes:

1. The Mineral Resources have an effective date of 18 May 2021 and the estimate was prepared using the definitions in CIM Definition Standards (10 May 2014).
2. All figures are rounded to reflect the relative accuracy of the estimate and therefore numbers may not appear to add precisely.
3. Mineral Resources that are not Mineral Reserves do not have demonstrated economic viability.
4. Mineral Resources are based on prices of US\$ 1600/oz gold and US\$ 20/oz silver.
5. Mineral Resources are based on a gold equivalent cutoff grade of 0.26 g/t.
6. The gold equivalent value is calculated as follows:

$$\text{Gold Equivalent (g/t)} = \text{Gold (g/t)} + \text{Silver (g/t)} / 74.67$$
, based on gold recovery of 70% and silver recovery of 75%.
7. Table 14-2 accompanies this Mineral Resource statement and shows all relevant parameters.
8. Mineral Resources are reported in relation to a conceptual constraining pit shell in order to demonstrate reasonable prospects for eventual economic extraction, as required by the definition of Mineral Resource in NI 43-101; mineralization lying outside of the pit shell is excluded from the Mineral Resource.

Table 14-2: Economic Parameters

Parameter	Units	
Gold Price Per Ounce	(US\$)	1600
Silver Price Per Ounce	(US\$)	20.00
Mining Cost Per Total Tonne	(US\$)	2.00
Process Cost Per Leach Tonne	(US\$)	8.25
G&A Cost Per Leach Tonne	(US\$)	1.00
Process Recoveries		
Gold Process Recovery	(%)	70.0%
Silver Process Recovery	(%)	75.0%
NSR Factor for Gold	(US\$)	36.01
NSR Factor for Silver	(US\$)	0.482
Breakeven NSR Cutoff	(US\$)	11.25
Internal NSR Cutoff	(US\$)	9.25
Silver Equivalent Divisor	(none)	74.67
Breakeven Gold Eq Cutoff Grade	(g/t)	0.31
Internal Gold Eq Cutoff Grade	(g/t)	0.26

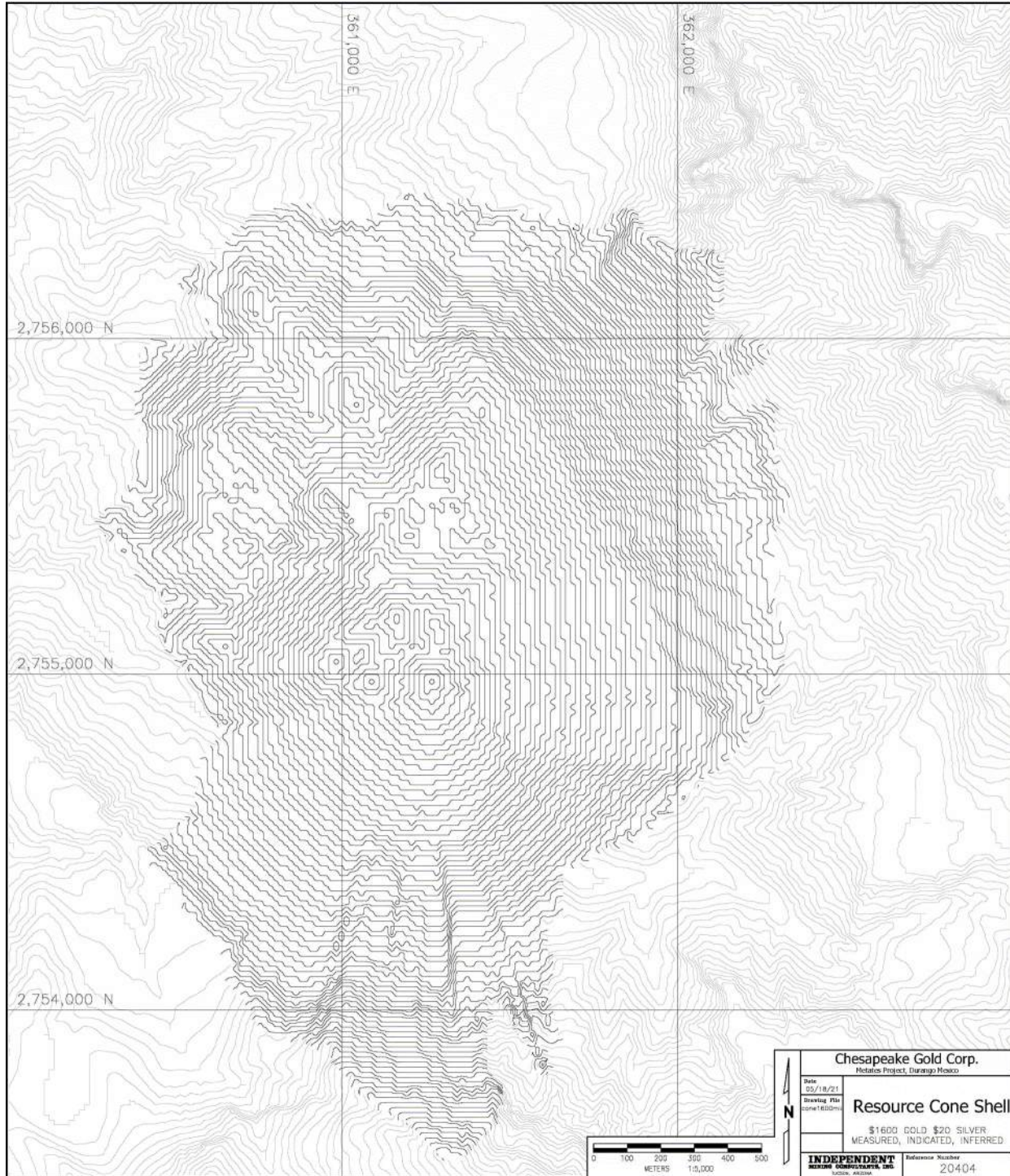

Figure 14-1: Mineral Resource Cone Shell, IMC 2021

The Mineral Resources are classified in accordance with the May 2014 Canadian Institute of Mining, Metallurgy and Petroleum (“CIM”) “CIM Definition Standards – For Mineral Resources and Mineral Reserves” adopted by the CIM Council (as amended, the “CIM Definition Standards”) in accordance with the requirements of NI 43-101. The Mineral

Resource estimate reflects the reasonable expectation that all necessary permits and approvals will be obtained and maintained.

There is no guarantee that any of the Mineral Resources will be converted to Mineral Reserve. The Inferred Mineral Resources included in this Technical Report meet the current definition of Inferred Mineral Resources. The quantity and grade of Inferred Mineral Resources are uncertain in nature and there has been insufficient exploration to define these inferred Mineral Resources as an Indicated Mineral Resource. It is, however, expected that the majority of Inferred Mineral Resource could be upgraded to Indicated Mineral Resource with continued exploration.

IMC does not believe that there are significant risks to the Mineral Resource estimates based on environmental, permitting, legal, title, taxation, socio-economic, marketing, or political factors. The project is in a jurisdiction friendly to mining. The most significant risks to the Mineral Resource are related to economic parameters such as prices lower than forecast, recoveries lower than forecast, or costs higher than the current estimates. The metallurgical recoveries used for the mineral resource estimate are based on limited test work. More testing is necessary and some work is in progress.

There has not been sufficient metallurgical testing completed as yet on samples from the Metates deposit to estimate projected sulphide heap leach metal recoveries. As such, the recoveries used in this report are based on previous metallurgical recoveries achieved on Metates material via various process routes including Biox leaching, autoclaves, Albion process, CIL, or RIL and from similar material using the proposed processing methods at other projects. Significant metallurgical testing is still required and is ongoing. However, there is sufficient test data to demonstrate that the mineralization is amenable to processing by alternative methods, such as pressure oxidation of a bulk sulphide flotation concentrate, although at a higher capital and processing cost.

14.2 DESCRIPTION OF THE RESOURCE MODEL

The updated mineral resource is based on a model developed by IMC during July 2014. The key points of the mineral resource model are summarized below.

14.2.1 General

The model is based on 15 m by 15 m by 15 m blocks. The model is not rotated.

14.2.2 Database and Compositing

The mineral resource model used in this study is based on 88,708 m of drilling in 234 holes. Table 14-3 shows the drilling by campaign. Cambior drilling amounts to 48,825 m in 140 holes, and Chesapeake drilling amounts to 39,883 m in 94 holes. Figure 14-2 shows hole locations by campaign. Table 14-3 and Figure 14-2 only include the drilling data incorporated into the 2014 model.

Table 14-3: Summary of Drilling by Campaign

Year	Company	Number of Holes	Meters
1993	Cambior	14	4,827
1994	Cambior	92	33,499
1995	Cambior	34	10,499
1993 to 1995	Cambior	140	48,825
2007 to 2008	Chesapeake	36	14,379
2011	Chesapeake	53	23,486
2013	Chesapeake	5	2,018
2007 to 2013	Chesapeake	94	39,883
TOTAL		234	88,708

METATES SULPHIDE HEAP LEACH PROJECT - PHASE 1
FORM 43-101F1 TECHNICAL REPORT

In 1993 and 1994, gold assays were factored by 0.8985 as per the GAII recommendation. Pre-1993 drilling was not used. There were no other adjustments to the data, i.e. there were not any cap grades applied to gold, silver, zinc, or copper.

The drillhole database was composited to regular 15 m bench composites.

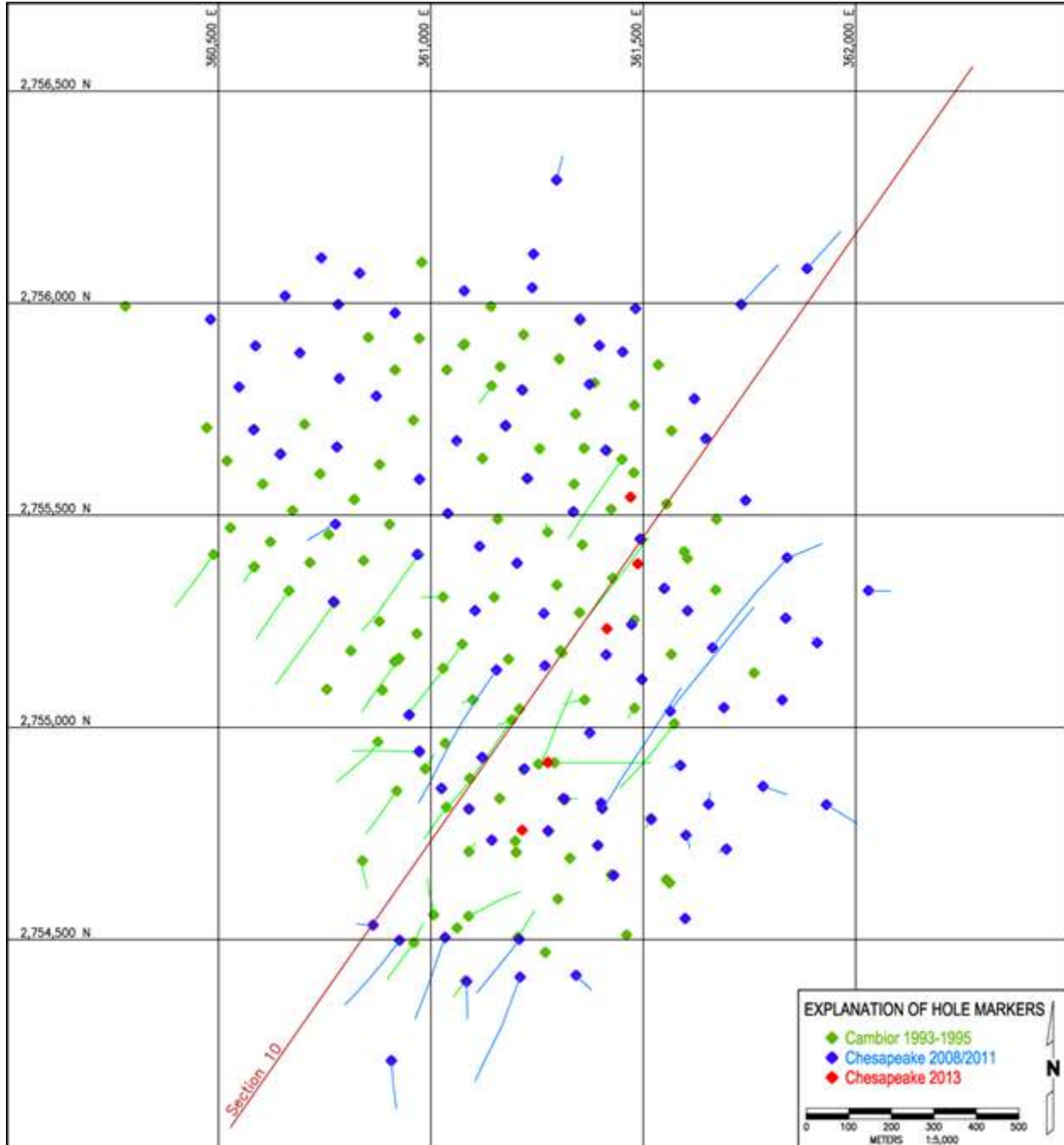

Figure 14-2: Hole Locations by Drilling Campaign, IMC 2016

14.2.3 Lithology Controls

Wire frame solids were developed for the 2012 model. These solids were used for the updated model; the five new holes from 2013 did not indicate changes were required. Wire frame solids were developed for intrusive (KQzl), intrusive breccia (KQbx), arenite (combined arenite and arenite-lutite Ka/Kal), lutite (combined lutite and lutite-arenite Kl/Kla), conglomerate (Kcg), basal conglomerate (Tcb), andesite (Tan), rhyolite (Try), and quaternary rhyolite or talus (Qry). These were used to assign lithology type to the model blocks.

The basal conglomerate (Tcb), rhyolite (Try) and andesite (Tan) were not estimated, and composites of these rock types were not used in estimation. The rhyolite and andesite are post-mineral lithologies. The basal conglomerate contains minor amounts of mostly silver mineralization that might be due to secondary enrichment.

The contacts of the mineralized lithologies, the intrusive, arenite, lutite, and conglomerate were not treated as boundaries for grade estimation. An analysis of the contacts did not indicate a significant change in mineralization across these boundaries.

Figure 14-3, Figure 14-4, and Figure 14-5 depict summary statistics of gold, silver and zinc grades in 15 m composites by the model lithology types.

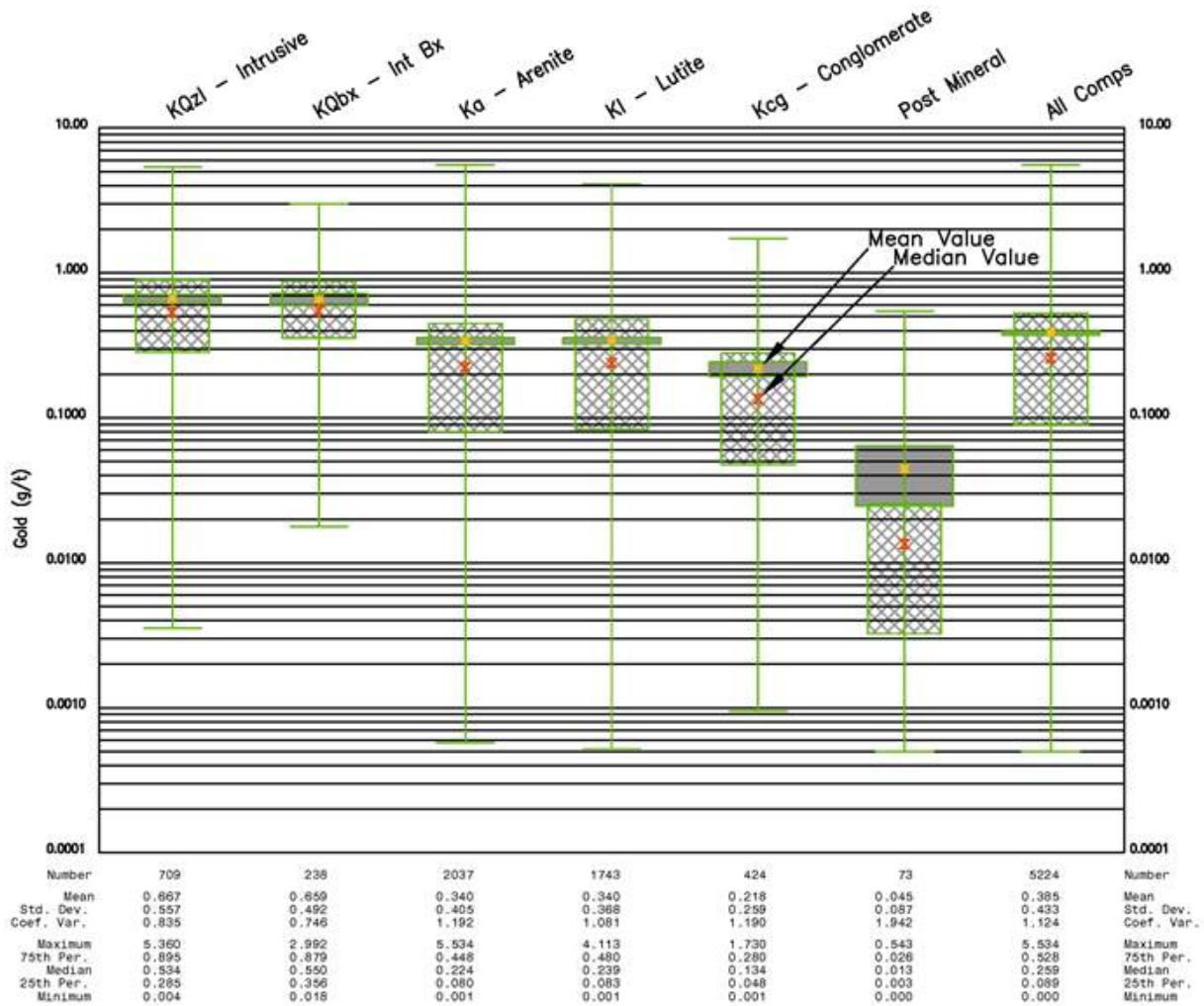

Gold Grades in 15m Composites by Lithology Type
 Light Gray Box Shows 25%, 75% and Median, Dark Gray Shows Mean and 95% Conf Interval

Figure 14-3: Gold Grades in 15 m Composites by Model Lithology Type, IMC 2016

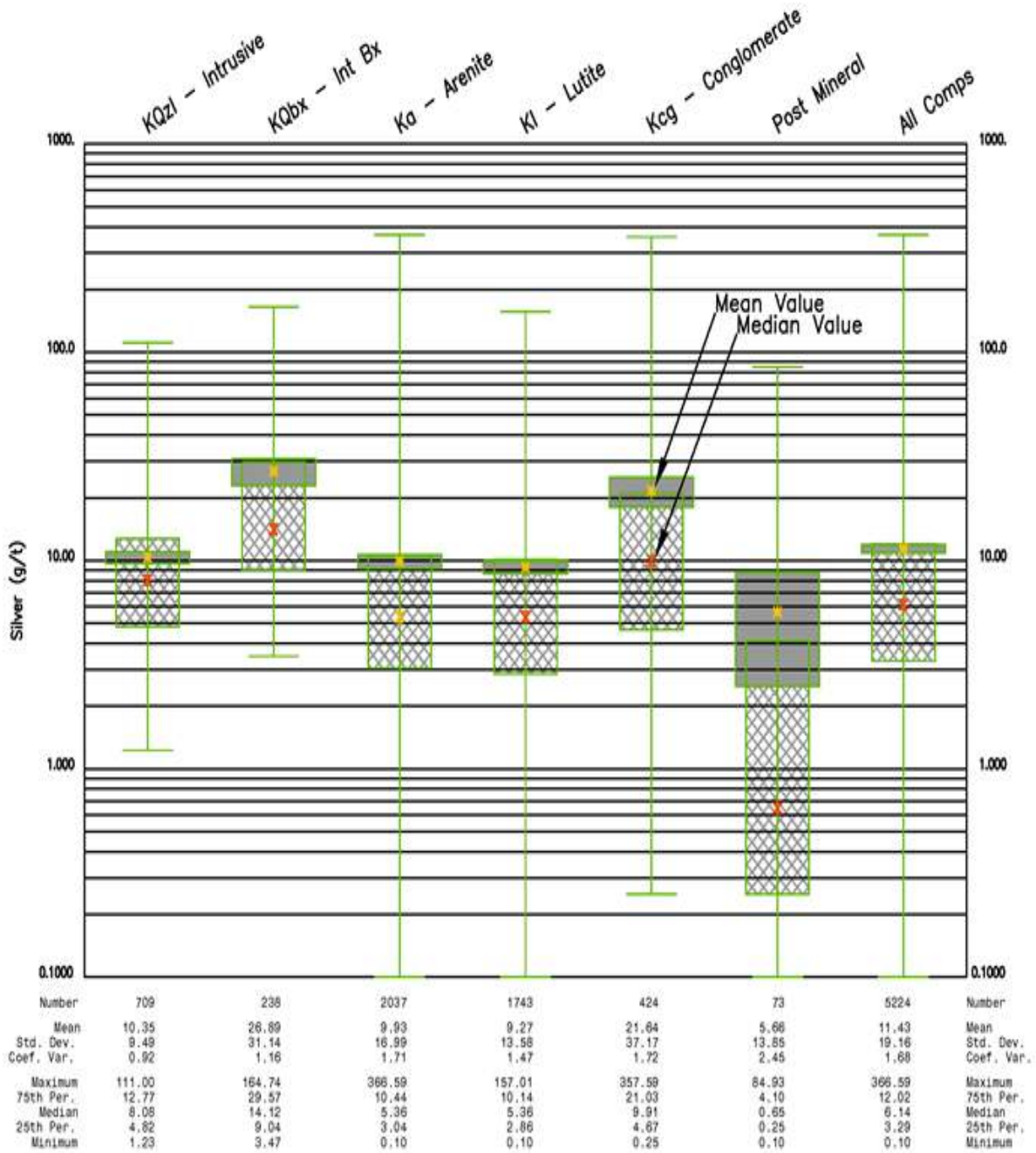

Silver Grades in 15m Composites by Lithology Type
Light Gray Box Shows 25%, 75% and Median, Dark Gray Shows Mean and 95% Conf Interval
Figure 14-4: Silver Grades in 15 m Composites by Model Lithology Type, IMC 2016

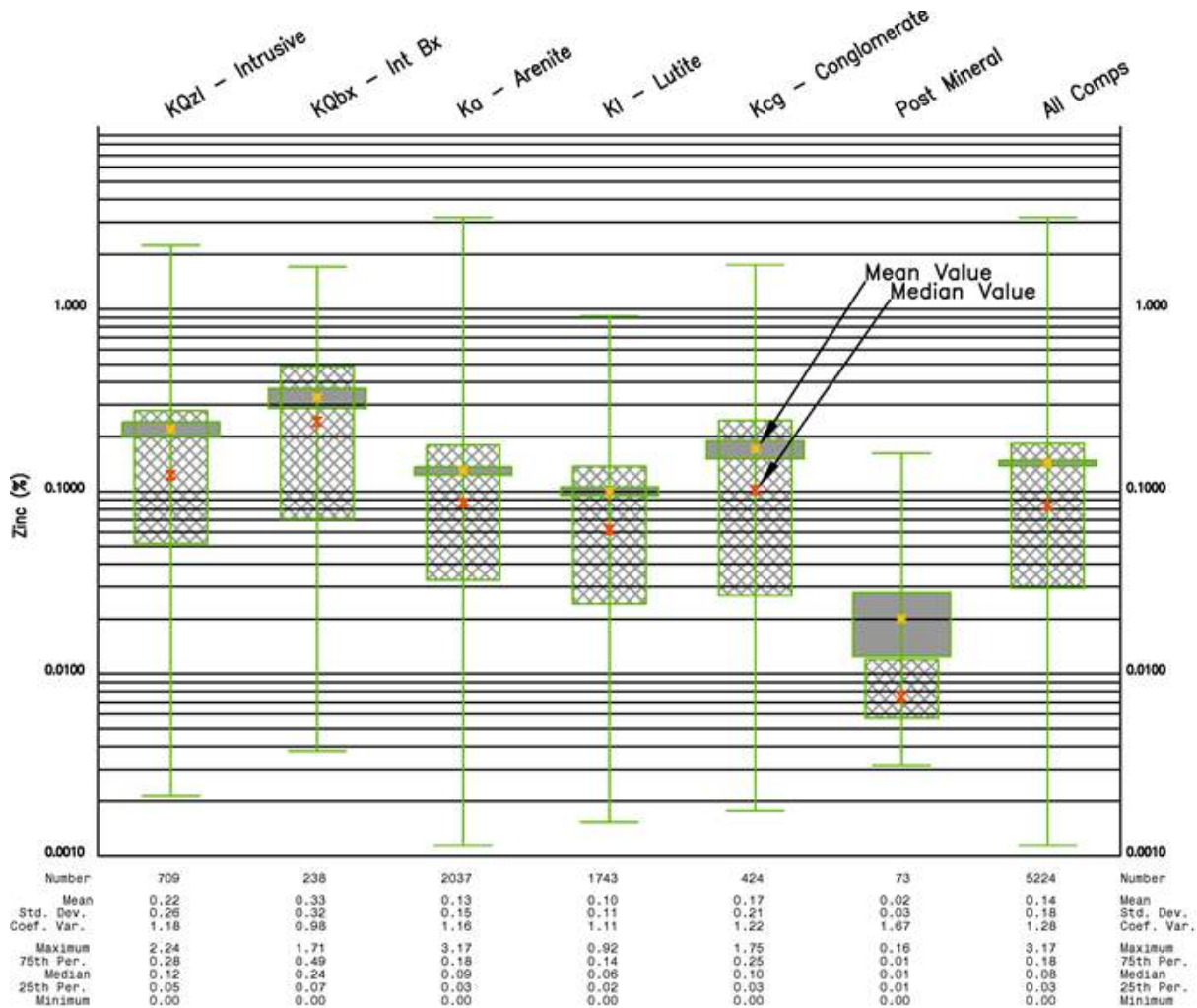

Zinc Grades in 15m Composites by Lithology Type
Light Gray Box Shows 25%, 75% and Median, Dark Gray Shows Mean and 95% Conf Interval

Figure 14-5: Zinc Grades in 15 m Composites by Model Lithology Type, IMC 2016

14.2.4 Structural Controls

The deposit area was divided into ten structural domains, as shown in Figure 14-6. Domains 8, 9, and 10 are the hinge of the syncline. In domains 4, 5 and 6, the bedding dips southwest. In domains 1, 2, 3 and 7, the bedding dips northeast. The domain boundaries such as the boundary between 2 and 3, 1 and 7, 4 and 5 are based on perceived slight changes in orientation and continuity of bedding as viewed on cross sections. The boundary between domains 1 and 2 is based on changes to the perceived orientation of the mineralization. Most of the intrusive rocks are in domains 1 and 7. The NE domains 4, 5, and 6 are all sediments.

The structural boundaries were not treated as hard boundaries for grade estimation; they only controlled search directions. The maximum extent of the zones was set about 150 m outside the drilling, which limits extrapolation outside the drilling information to this distance.

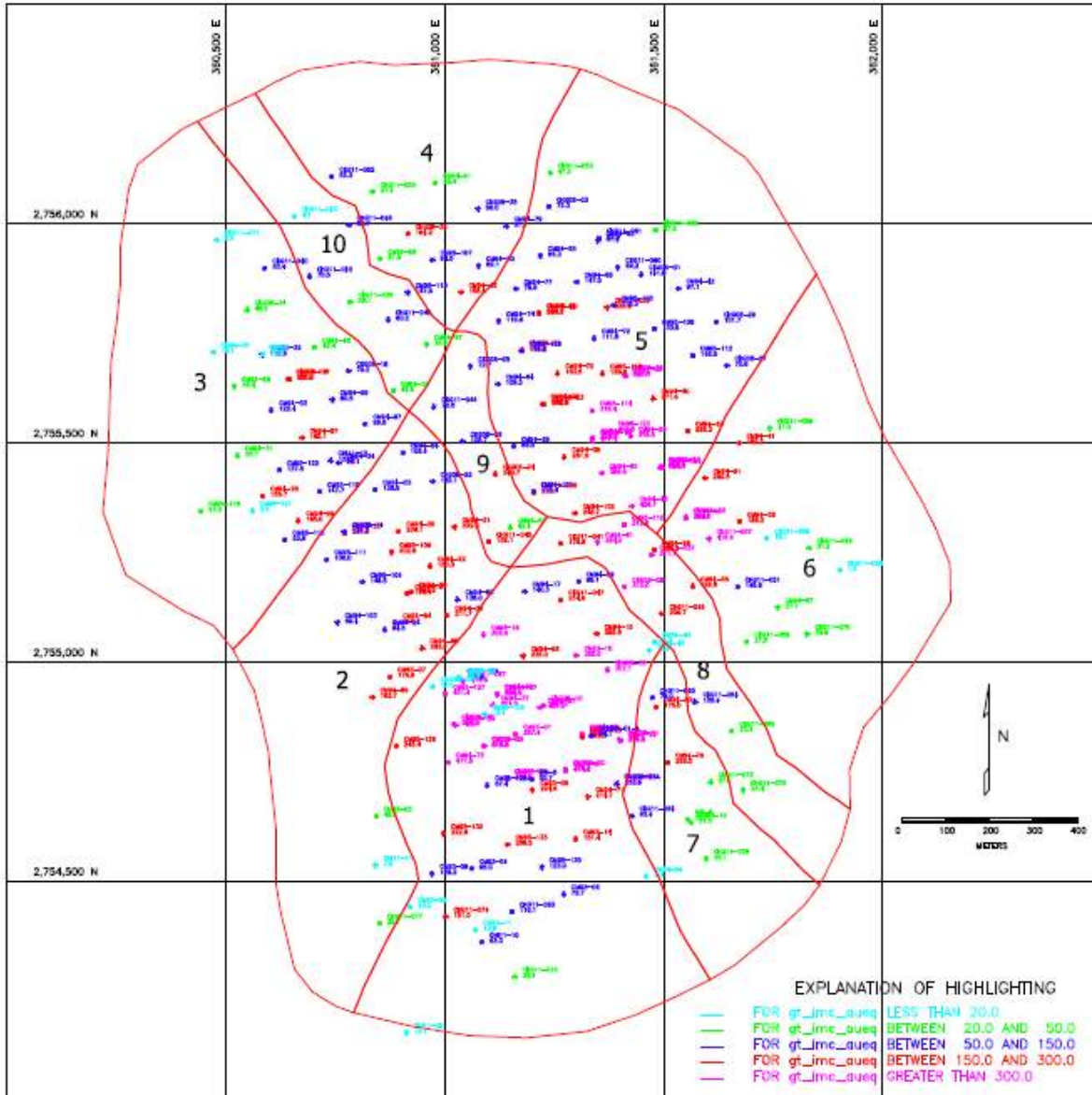

Figure 14-6: Structural Domains and Estimation Boundary, IMC 2016

14.2.5 Grade Estimation

Table 14-4 shows the estimation parameters used for gold, silver, and zinc respectively by structural domain and rock type. Block grades for gold, silver, and zinc were estimated by inverse distance to the third power (ID3) in all cases. The 15 m bench composites were used for the estimation. A maximum of eight composites and a minimum of one composite were used along with a maximum of two composites per hole. In terms of the distribution of mining block grades, the ID3 estimation falls about midway between ordinary kriging with 15 m composites (probably too much over-smoothing) and a nearest neighbor (NNP) method with 15 m composites (not enough smoothing). IMC also examined the grade distributions of ordinary kriging and ID3 with 7.5 m composites prior to selecting the final method.

14.2.5.1 Gold

Search orientations and radii by structural domain for gold are as follows:

For structural domains 1 and 7, the South Domain in previous studies, the primary axis is oriented N50°E with a plunge of 40° (down). The secondary axis dips 23° to the southeast. Search radii are 210 m in the primary direction, 140 m in the secondary direction and 50 m in the tertiary direction. These directions are also comparable to stratigraphy except the primary axis is down the dip direction rather than the strike direction. The 210 m/140 m searches are based on slightly more anisotropy evident in the variograms than the other zones.

For structural domain 2, part of the NW Domain in previous studies, the primary axis is oriented N40°W with a plunge of 23° (down). The secondary axis dips 40° to the northeast for intrusive rocks and 45° northeast for sedimentary rocks. Search radii are 200 m in the primary, 150 m in the secondary, and 50m in the tertiary direction.

For structural domain 3, part of the NW Domain in previous studies, the primary axis is oriented N40°W with no dip. The secondary axis dips 40° to the northeast for intrusive rocks and 30° northeast for sedimentary rocks. Search radii are 200 m in the primary, 150 m in the secondary, and 50 m in the tertiary direction. The slight anisotropy is due to clearer variogram interpretation in the primary versus secondary direction. Note that the orientations are comparable to stratigraphy in this zone.

For structural domains 4, 5, and 6, the NE Domain in previous studies, the primary axis is oriented N40°W with a plunge of 23° (down). The secondary axis dips 30° to the southwest for domains 4 and 5, and 40° southwest for domain 6. This is consistent with stratigraphy in the domains. Search radii are 200 m in the primary, 150 m in the secondary, and 50 m in the tertiary direction.

Structural domains 8, 9, and 10 are the hinge zone of the syncline. The primary axis is oriented N30°W for domains 8 and 10, and N20°W for domain 9. The search is flat and is 250m in the primary direction, 120 m in the secondary direction, and 50 m in the tertiary direction. Figure 14-7 shows gold grades on cross section 10.

METATES SULPHIDE HEAP LEACH PROJECT - PHASE 1
FORM 43-101F1 TECHNICAL REPORT

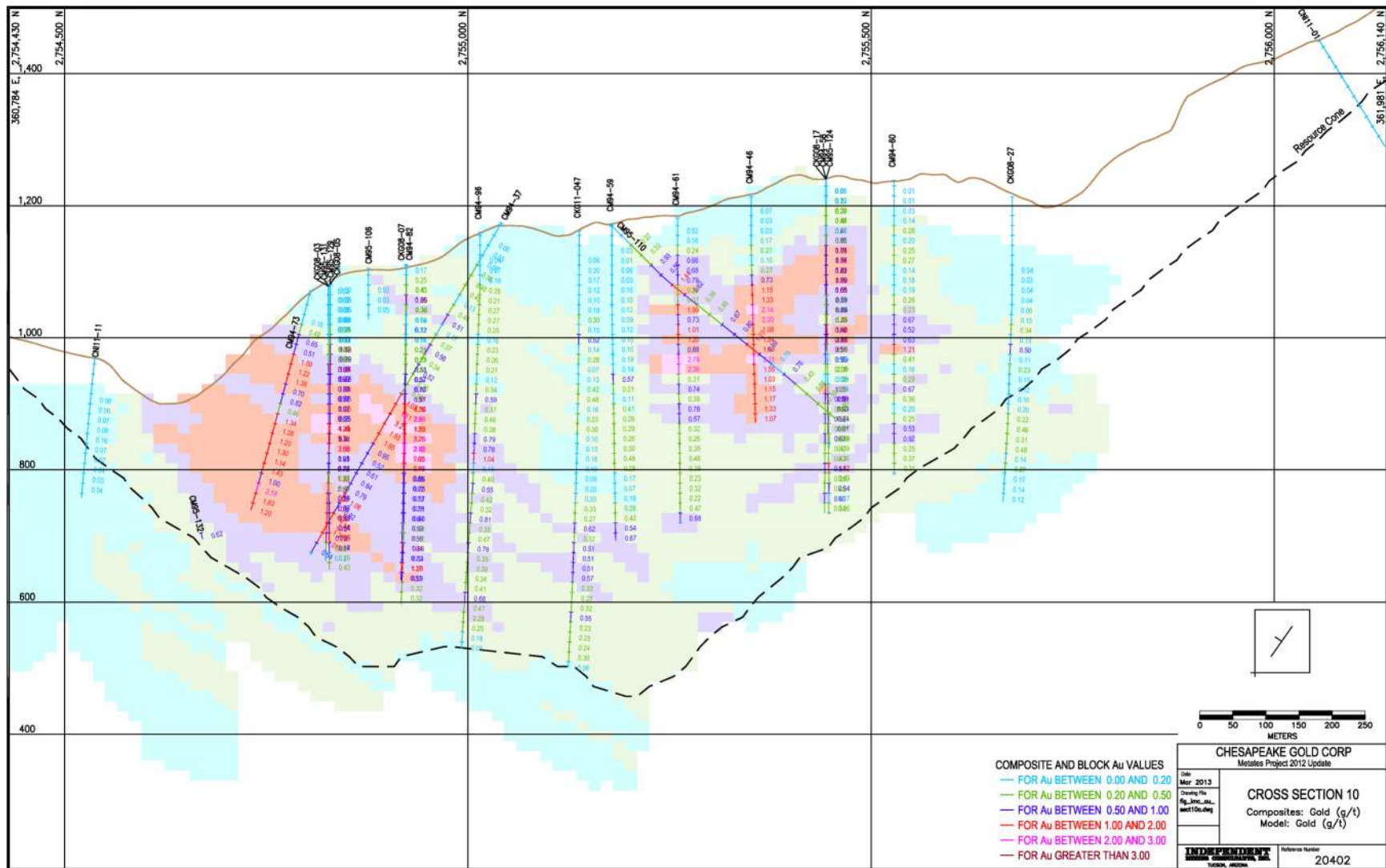

Figure 14-7: Gold Grades on Cross Section 10, IMC 2016

14.2.5.2 Silver and Zinc

Silver and zinc are not well correlated with gold but tend to correlate with each other. Higher silver and zinc grades often appear higher in elevation in the mineralized material body than the gold grades. In domains 1, 2, 3, and 7, silver and zinc were estimated with the same orientations and search radii as gold. In the domains 4, 5, and 6, silver and zinc were estimated with a flat search with a circular search radius of 175 m. Most of the higher-grade silver and zinc are in a flat blanket, mostly above the 1000 m elevation, in those domains. In the hinge domains, 8, 9, and 10, silver and zinc were also estimated with the same parameters as gold. Figure 14-8 shows silver grades on cross section 10.

METATES SULPHIDE HEAP LEACH PROJECT - PHASE 1
FORM 43-101F1 TECHNICAL REPORT

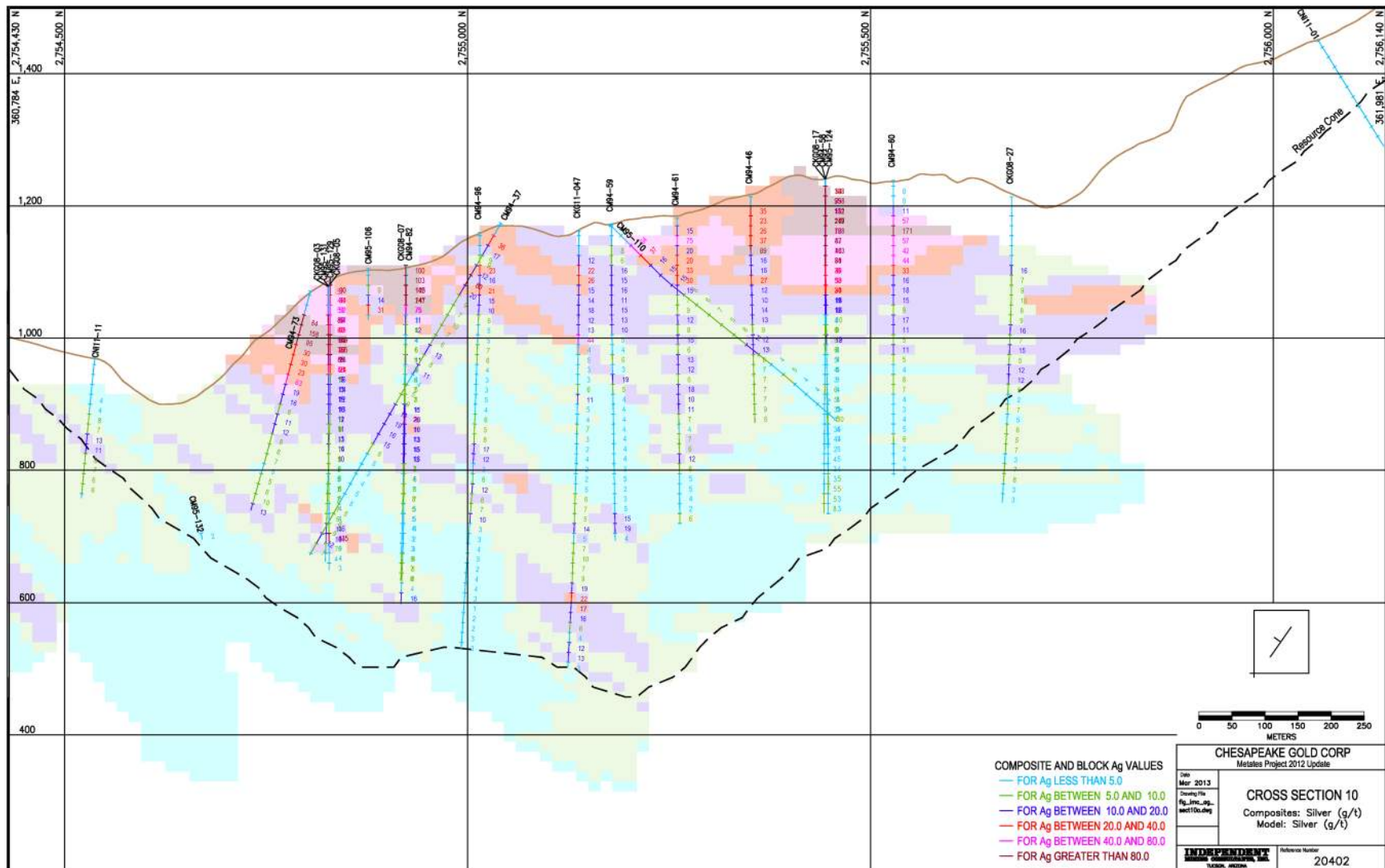

Figure 14-8: Silver Grades on Cross Section 10, IMC 2016

14.2.5.3 Sulphur

Grade estimation was also conducted for sulphur. Sulphur is under-sampled in the database since Cambior did not assay for it. However, there is a relatively good positive correlation between sulphur and gold, i.e. a good correlation between gold and pyrite. Figure 14-9 shows a log-log plot (base e) of sulphur versus gold for intrusive rocks. The equation for the regression line is:

$$\text{Log}_e \text{ sulphur} = 1.887498 + 0.405148 \text{ log}_e \text{ gold}$$

In real space, the equation is:

$$\text{Sulphur} = 6.6028 \text{ gold}^{0.405148}$$

Figure 14-10 shows the same log-log plot of sulphur versus gold for sedimentary rock types. The equation for the regression line is:

$$\text{Log}_e \text{ sulphur} = 1.722762 + 0.402516 \text{ log}_e \text{ gold}$$

In real space, the equation is:

$$\text{Sulphur} = 5.6000 \text{ gold}^{0.402516}$$

These equations were used to fill in missing sulphur grades in the 15 m composites. Block sulphur grades were estimated using the same parameters used for gold.

METATES SULPHIDE HEAP LEACH PROJECT - PHASE 1
FORM 43-101F1 TECHNICAL REPORT

Table 14-4: Estimation Parameters

Structural Zone	Rock Type	Mineral	Description	Rotation Angles (Note 1)			Search Radii (Meters)			Composites			ID Power
				Theta	Phi	Psi	Major	Minor	Tertiary	Min	Max	Max/Hole	
1	All	Gold	SW Zone - Intrusives Predominate	50	-40	23	210	140	50	1	8	2	3
2	KQzl,KQbx	Gold	SW Zone - Some Intrusives	-40	-23	40	200	150	50	1	8	2	3
2	Ka,Kl	Gold	SW Zone - Some Intrusives	-40	-23	45	200	150	50	1	8	2	3
3	KQzl,KQbx	Gold	SW of Hinge	-40	0	40	200	150	50	1	8	2	3
3	Ka,Kl	Gold	SW of Hinge	-40	0	30	200	150	50	1	8	2	3
4	All	Gold	NE of Hinge	-40	-23	-30	200	150	50	1	8	2	3
5	All	Gold	NE of Hinge	-40	-23	-30	200	150	50	1	8	2	3
6	All	Gold	NE of Hinge	-40	-23	-40	200	150	50	1	8	2	3
7	All	Gold	Minor Zone SW of Hinge	50	-40	23	210	140	50	1	8	2	3
8	All	Gold	Hinge Zone - Flat Search	-30	0	0	250	120	50	1	8	2	3
9	All	Gold	Hinge Zone - Flat Search	-20	0	0	250	120	50	1	8	2	3
10	All	Gold	Hinge Zone - Flat Search	-30	0	0	250	120	50	1	8	2	3
1	All	Silver	SW Zone - Intrusives Predominate	50	-40	23	210	140	50	1	8	2	3
2	KQzl,KQbx	Silver	SW Zone - Some Intrusives	-40	-23	40	200	150	50	1	8	2	3
2	Ka,Kl	Silver	SW Zone - Some Intrusives	-40	-23	45	200	150	50	1	8	2	3
3	KQzl,KQbx	Silver	SW of Hinge	-40	0	40	200	150	50	1	8	2	3
3	Ka,Kl	Silver	SW of Hinge	-40	0	30	200	150	50	1	8	2	3
4	All	Silver	NE of Hinge	0	0	0	175	175	50	1	8	2	3
5	All	Silver	NE of Hinge	0	0	0	175	175	50	1	8	2	3
6	All	Silver	NE of Hinge	0	0	0	175	175	50	1	8	2	3
7	All	Silver	Minor Zone SW of Hinge	50	-40	23	210	140	50	1	8	2	3
8	All	Silver	Hinge Zone - Flat Search	-30	0	0	250	120	50	1	8	2	3
9	All	Silver	Hinge Zone - Flat Search	-20	0	0	250	120	50	1	8	2	3
10	All	Silver	Hinge Zone - Flat Search	-30	0	0	250	120	50	1	8	2	3
1	All	Zinc	SW Zone - Intrusives Predominate	50	-40	23	210	140	50	1	8	2	3
2	KQzl,KQbx	Zinc	SW Zone - Some Intrusives	-40	-23	40	200	150	50	1	8	2	3
2	Ka,Kl	Zinc	SW Zone - Some Intrusives	-40	-23	45	200	150	50	1	8	2	3
3	KQzl,KQbx	Zinc	SW of Hinge	-40	0	40	200	150	50	1	8	2	3
3	Ka,Kl	Zinc	SW of Hinge	-40	0	30	200	150	50	1	8	2	3
4	All	Zinc	NE of Hinge	0	0	0	175	175	50	1	8	2	3
5	All	Zinc	NE of Hinge	0	0	0	175	175	50	1	8	2	3
6	All	Zinc	NE of Hinge	0	0	0	175	175	50	1	8	2	3
7	All	Zinc	Minor Zone SW of Hinge	50	-40	23	210	140	50	1	8	2	3
8	All	Zinc	Hinge Zone - Flat Search	-30	0	0	250	120	50	1	8	2	3
9	All	Zinc	Hinge Zone - Flat Search	-20	0	0	250	120	50	1	8	2	3
10	All	Zinc	Hinge Zone - Flat Search	-30	0	0	250	120	50	1	8	2	3

Note 1 IMC Convention for Rotation Angles. Same as GSLIB convention except sign of Psi is opposite.

theta rotation of γ (north) axis clockwise to principal direction in the horizontal plane

phi dip of principal axis, negative is down

psi rotation around principal axis, clockwise is negative. Perspective is outside system looking toward origin. (GSLIB is inside system).

* REGRESSION ANALYSIS LINEAR REGRESSION
 DEPENDENT VARIABLE: sulfur INDEPENDENT VARIABLE: imc_au

variable	total cases	non-missing	mean	std dev	minimum	maximum
sulfur	260	260	.52151E+01	.20692E+01	.17851E+00	.92218E+01
imc_au	260	260	.66196E+00	.50218E+00	.35375E-02	.29923E+01
standard error of estimate			.1276	correlation coefficient		.6227
sulfur =	1.857811 +		.379547 * imc_au			

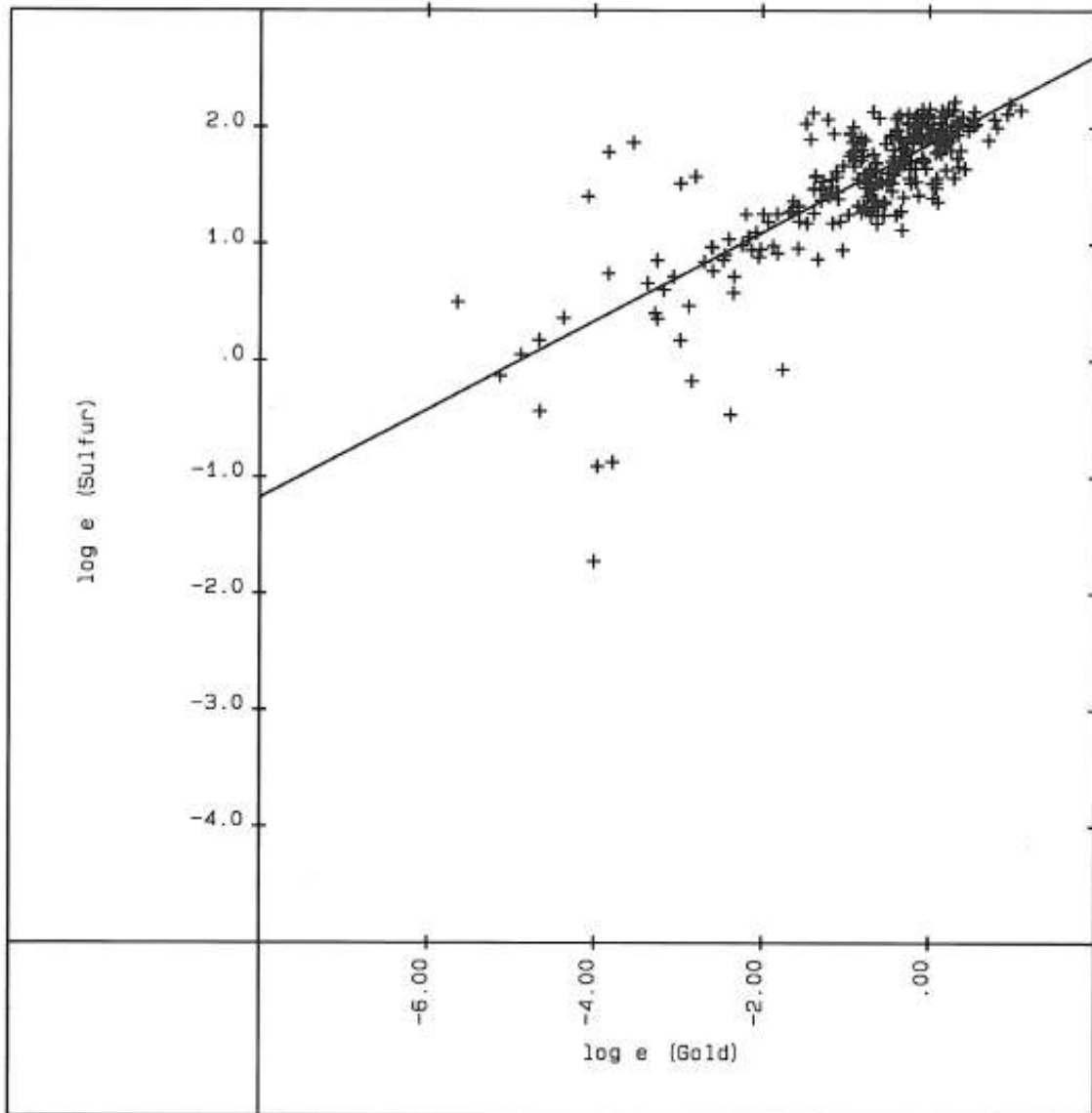

Figure 14-9: Gold vs. Sulphur – Intrusive Rock Types, IMC 2016

* REGRESSION ANALYSIS LINEAR REGRESSION
 DEPENDENT VARIABLE: sulfur INDEPENDENT VARIABLE: imc_au

variable	total cases	non-missing	mean	std dev	minimum	maximum
sulfur	1892	1892	.29058E+01	.18627E+01	.19480E-01	.98650E+01
imc_au	1892	1892	.24871E+00	.33920E+00	.52280E-03	.55336E+01
standard error of estimate			.1918		correlation coefficient	.6634
sulfur =	1.717883 +		.397964 * imc_au			

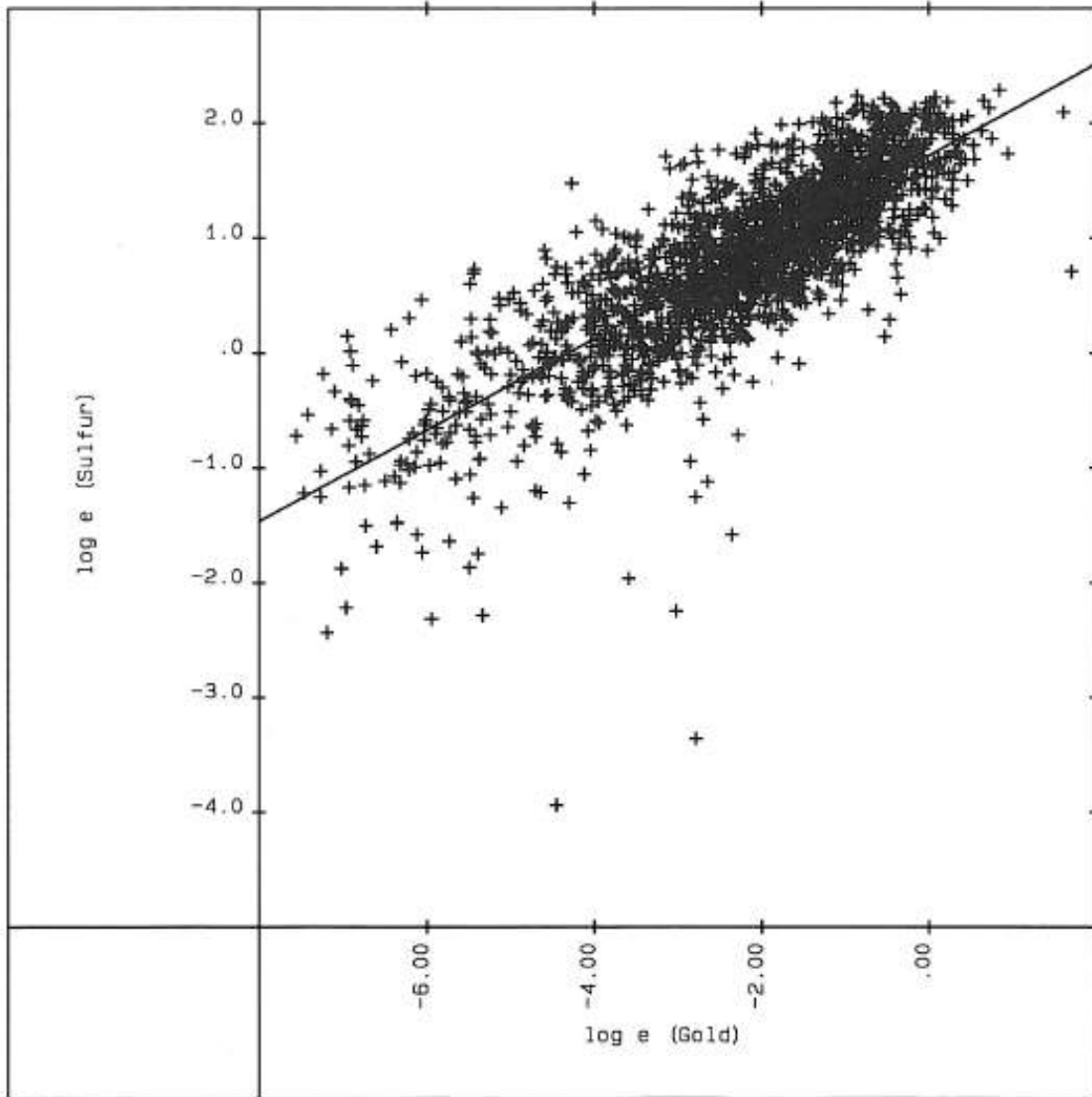

Figure 14-10: Gold vs Sulphur – Sedimentary Rock Types, IMC 2016

14.2.6 Resource Classification

The number of composites and the average distance to the composites were stored in the block model and used for resource classification. This was based on the gold grade estimation. The following procedure was then used to establish the resource classification for each:

All blocks with a gold grade estimate were set to inferred resource.

The following blocks were then upgraded to indicated resource.

Blocks estimated with 7 or 8 composites and average distance ≤ 150 m

Blocks estimated with 5 or 6 composites and average distance ≤ 125 m

Blocks estimated with 3 or 4 composites and average distance ≤ 100 m

The following blocks were then upgraded to measured resource.

Blocks estimated with 7 or 8 composites and average distance ≤ 75 m

Note that the block grade estimation limited the number of composites to two per hole, thus 3 or 4 composites indicates a minimum of two holes, 5 or 6 composites a minimum of three holes, and 7 or 8 composites a minimum of four holes.

Figure 14-11 shows a cross tabulation of blocks by number of composites and average distance. The top number in each cell is the number of blocks in the composite number/average distance class. The second and third numbers in each cell are number of blocks and a relative kriging standard deviation. Though the grade estimates were completed by inverse distance, IMC also completed an ordinary kriging estimate for gold to obtain a relative kriging standard deviation to assist in establishing the resource classification. Measured blocks generally correspond to a relative kriging standard deviation less than 0.50 and a minimum of four holes. Indicated blocks generally correspond to a relative kriging standard deviation less than 0.85. Figure 14-12 shows the resource classification on cross section 10.

METATES SULPHIDE HEAP LEACH PROJECT - PHASE 1
FORM 43-101F1 TECHNICAL REPORT

		Number of Composites								
count n_STDEV STDEV		- 1	- 2	- 3	- 4	- 5	- 6	- 7	- 8	Row Total
Average Distance	>= .0 < 25.0	0 .00	22 .79	0 .00	0 .00	0 .00	0 .00	0 .00	43 .35	65 54 .44
	>= 25.0 < 50.0	6 1.10	93 .95	17 .75	19 .50	3 .46	23 .43	0 .00	2309 .39	2470 2386 .40
	>= 50.0 < 75.0	60 .88	205 1.01	57 .77	168 .61	27 .56	225 .50	33 .48	23381 .46	24156 23799 .46
	>= 75.0 < 100.0	106 .96	295 .98	135 .84	505 .77	251 .73	878 .62	316 .61	27956 .53	30442 29412 .54
	>= 100.0 < 125.0	131 1.02	378 .97	170 .94	733 .86	301 .83	1060 .72	650 .68	12244 .60	15667 14712 .63
	>= 125.0 < 150.0	142 .99	561 .98	173 .97	414 .91	205 .86	547 .84	288 .81	1825 .70	4155 3204 .78
	>= 150.0 < 175.0	129 1.04	438 1.03	82 1.04	134 .98	45 .91	126 .87	30 .90	75 .88	1059 485 .96
	>= 175.0 < 200.0	123 1.06	179 1.06	10 1.07	4 .98	0 .00	0 .00	0 .00	0 .00	316 65 1.06
	>= 200.0 < 225.0	12 .98	6 .00	0 .00	0 .00	0 .00	0 .00	0 .00	0 .00	18 1 .98
	Column Total	709 1.00	2177 .99	644 .92	1977 .82	832 .80	2859 .69	1317 .69	67833 .52	78348 74118 .54

Figure 14-11: Resource Classification, IMC 2016

METATES SULPHIDE HEAP LEACH PROJECT - PHASE 1
FORM 43-101F1 TECHNICAL REPORT

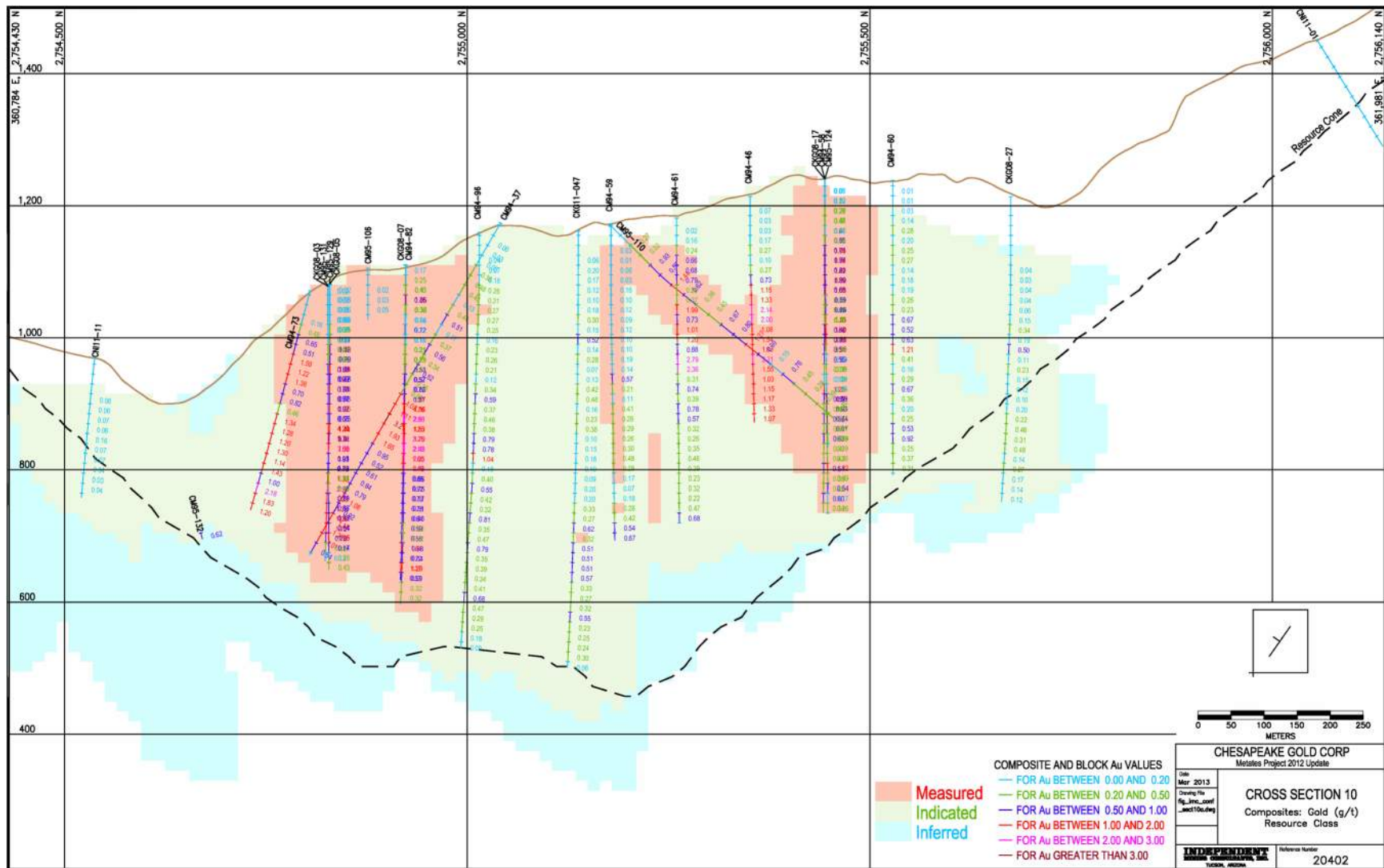

Figure 14-12: Cross Section 10 Showing Resource Classification, IMC 2016

14.2.7 Bulk Density

The rock density database consists of 652 total samples collected during the various drilling campaigns to estimate specific gravity of the various Metates rock types. This number excludes three outliers of 1.437, 3.347, and 3.570. Note also that there are six samples described as Sedimentary Breccia that do not correspond to a rock type developed in the model. The specific gravity estimates are also assumed to represent accurate bulk density estimates without any adjustments. Table 14-5 summarizes these tests.

Table 14-5: Specific Gravity Measurement by Rock Type

Code	Description	Number	Mean	Std Dev	Min	Max
All	All Samples	652	2.699	0.147	1.86	3.20
KQzl	Intrusive	65	2.696	0.100	2.41	2.98
Kqbx	Intrusive Breccia	19	2.745	0.083	2.59	2.88
Ka	Arenite	184	2.702	0.084	2.48	3.20
Kal	Arenite-Lutite	123	2.729	0.066	2.52	2.95
Kl	Lutite	75	2.784	0.069	2.69	3.00
Kla	Lutite-Arenite	68	2.778	0.080	2.64	3.12
Kcg	Conglomerate	58	2.699	0.107	2.54	3.12
Tcb	Basal Conglomerate	14	2.557	0.094	2.34	2.68
Try	Rhyolite	18	2.107	0.181	1.86	2.48
Tan	Andesite	27	2.433	0.165	2.02	2.69
KQzl/Kqbx	Intrusive/Breccia	83	2.707	0.099	2.41	2.98
Ka/Kal	Arenite/Arenite-Lutite	306	2.713	0.079	2.48	3.20
Kl/Kla	Lutite/Lutite-Arenite	143	2.781	0.074	2.64	3.12
Ksbx	Sedimentary Breccia	6	2.795	0.103	2.72	2.99

The arenite/arenite-lutite rock types were combined in the block model and assigned the average bulk density of 2.713 tonnes/m³. Also, the lutite/lutite-arenite rock types were combined in the model and assigned the average bulk density of 2.781 tonnes/m³.

14.2.8 Sensitivity to Grade Capping

The data presented in this section was developed for the 2012 model update. The results presented are still considered valid; the 2013 drilling consisted of only five new holes.

An analysis to evaluate the effect of grade capping on the Metates mineral resource was also done. Grades were not capped for the base case mineral resource.

For this exercise IMC capped gold and silver in 3-m assays at the 99.5% level by the main rock types. Table 14-6 shows the caps by rock type and the number of assays capped. In general, this is more aggressive capping than IMC would typically do. Usually, caps are applied to the highest half-dozen to dozen grades and are typically applied at breaks in the grade distribution. For this work, it was desired to apply something less subjective (other than the chosen percentile). Assays above the shown grades were cut to those grades. The 139 capped gold assays affected 136, 15-m composites and the 140 capped silver assays affected 114, 15-m composites.

Table 14-6: Cap Grades for Silver and Gold Assays

Rock Code	Rock Type	Gold Cap	No. of Au Assays	Silver Cap	No. of Au Assays
10	Intrusive (KQzl)	5.65	18	74	18
11	Intrusive Breccia (KQbx)	3.64	6	259	7
20	Arenite (Ka – Sandstone)	3.31	56	120	56
30	Lutite (Kl – Mudstone)	2.94	48	110	48
41	Conglomerate (Kcg)	2.68	11	310	11

For all measured and indicated mineral resources, based on the cone shell, the grade capping resulted in 0.5% less resource tonnes at a 2.5% lower gold grade, and a 4.5% lower silver grade for 3.0% less contained gold ounces and 5.9% less contained silver ounces. This indicates capping the assays would not have a significant impact on results.

14.2.9 Comparison of the Current and Prior Mineral Resource Estimate

Table 14-7 is a comparison of the current mineral resource with the prior mineral resource as presented in the April 29, 2016 Technical Report. The resource block model has not changed since the prior mineral resource, since the 2021 drilling was not available in time to be incorporated into this study. The difference in the mineral resource estimates is due only to changes in commodity prices, metal recoveries and unit costs. Table 14-8 compares these parameters. Note that the 2016 mineral resource estimate assumed a higher processing rate and higher projected gold recovery than the current mineral resource estimate. However, due to the higher gold price for the current mineral resource estimate, the internal and breakeven cut-off grades are lower.

In terms of percent difference on the bottom section of Table 14-7 and looking at the sum of measured and indicated mineral resources, the current mineral resource has 14.9% more resource tonnes at an 8.6% lower gold grade and 6.3% lower silver grade for 5.1% more contained gold ounces and 7.7% more silver ounces. For the intrusive hosted mineralization, the current mineral resource has 4.1% more mineral resource tonnes at a 3.2% lower gold grade and a 2.1% lower silver grade for 0.7% more contained gold ounces and 1.9% more silver ounces. For the sediment hosted mineralization, the current mineral resource has 17.9% more mineral resource tonnes at a 9.4% lower gold grade and 7.3% lower silver grade for 6.8% more contained gold ounces and 9.3% more contained silver ounces. The main difference in the mineral resource estimates is due to the sediment hosted rocks and the main factor is the lower cut-off grade for the 2021 mineral resource estimate. The lower grade sediment hosted resources are more sensitive to the cut-off grade used for the mineral resource.

It is also noted that the 2016 mineral resource estimate included zinc mineral resources. This is not included in the current mineral resource estimate. The processing method proposed for this Technical Report is not designed to recover salable zinc metal.

Table 14-7: Comparison of 2021 versus 2016 Mineral Resource Estimate

Metates Mineral Resource - May 18, 2021						
Resource Category	Ktonnes	Gold Eq. (g/t)	Gold (g/t)	Silver (g/t)	Gold (koz)	Silver (koz)
Measured Mineral Resource	395,419	0.793	0.585	15.5	7,440.9	197,327
<i>Intrusive Host</i>	103,058	0.983	0.762	16.5	2,524.8	54,639
<i>Sediment Host</i>	292,361	0.726	0.523	15.2	4,916.1	142,688
Indicated Mineral Resource	907,021	0.582	0.424	11.8	12,359.6	344,673
<i>Intrusive Host</i>	145,963	0.755	0.595	11.9	2,792.3	55,939
<i>Sediment Host</i>	761,058	0.549	0.391	11.8	9,567.4	288,734
Measured/Indicated Resource	1,302,440	0.646	0.473	12.9	19,800.6	542,000
<i>Intrusive Host</i>	249,021	0.849	0.664	13.8	5,317.1	110,578
<i>Sediment Host</i>	1,053,419	0.598	0.428	12.7	14,483.4	431,422
Inferred Mineral Resource	62,249	0.441	0.321	9.0	642.6	17,965
<i>Intrusive Host</i>	3,436	0.505	0.425	6.0	47.0	663
<i>Sediment Host</i>	58,813	0.437	0.315	9.2	595.6	17,302

Metates Mineral Resource - April 29, 2016						
Resource Category	Ktonnes	Gold Eq. (g/t)	Gold (g/t)	Silver (g/t)	Gold (koz)	Silver (koz)
Measured Mineral Resource	371,125	0.829	0.611	16.1	7,287.9	192,323
<i>Intrusive Host</i>	101,151	0.999	0.773	16.7	2,513.9	54,311
<i>Sediment Host</i>	269,974	0.765	0.550	15.9	4,774.0	138,012
Indicated Mineral Resource	761,994	0.644	0.472	12.7	11,552.1	310,923
<i>Intrusive Host</i>	138,125	0.789	0.623	12.2	2,766.7	54,179
<i>Sediment Host</i>	623,869	0.612	0.438	12.8	8,785.5	256,744
Measured/Indicated Resource	1,133,119	0.705	0.517	13.8	18,840.0	503,246
<i>Intrusive Host</i>	239,276	0.878	0.686	14.1	5,280.6	108,489
<i>Sediment Host</i>	893,843	0.658	0.472	13.7	13,559.5	394,756
Inferred Mineral Resource	51,543	0.517	0.387	9.5	641.4	15,787
<i>Intrusive Host</i>	2,885	0.578	0.489	6.6	45.4	612
<i>Sediment Host</i>	48,658	0.513	0.381	9.7	596.0	15,175

Metates Mineral Resource - Percent Difference 2021 vs 2016						
Resource Category	Ktonnes	Gold Eq. (g/t)	Gold (g/t)	Silver (g/t)	Gold (koz)	Silver (koz)
Measured Mineral Resource	6.5%	-4.3%	-4.2%	-3.7%	2.1%	2.6%
<i>Intrusive Host</i>	1.9%	-1.6%	-1.4%	-1.3%	0.4%	0.6%
<i>Sediment Host</i>	8.3%	-5.1%	-4.9%	-4.5%	3.0%	3.4%
Indicated Mineral Resource	19.0%	-9.6%	-10.1%	-6.9%	7.0%	10.9%
<i>Intrusive Host</i>	5.7%	-4.3%	-4.5%	-2.3%	0.9%	3.2%
<i>Sediment Host</i>	22.0%	-10.3%	-10.7%	-7.8%	8.9%	12.5%
Measured/Indicated Resource	14.9%	-8.3%	-8.6%	-6.3%	5.1%	7.7%
<i>Intrusive Host</i>	4.1%	-3.2%	-3.2%	-2.1%	0.7%	1.9%
<i>Sediment Host</i>	17.9%	-9.1%	-9.4%	-7.3%	6.8%	9.3%
Inferred Mineral Resource	20.8%	-14.7%	-17.0%	-5.8%	0.2%	13.8%
<i>Intrusive Host</i>	19.1%	-12.6%	-13.1%	-9.1%	3.5%	8.3%
<i>Sediment Host</i>	20.9%	-14.8%	-17.3%	-5.7%	-0.1%	14.0%

Table 14-8: Comparison of Parameters for Mineral Resource Estimates

Parameter	Units	2021	2016
Gold Price Per Ounce	(US\$)	1600	1200
Silver Price Per Ounce	(US\$)	20.00	19.20
Processing Rate	(mtpy)	5,475	32,850
Mining Cost Per Total Tonne	(US\$)	2.00	1.40
Process Cost Tonne Processed	(US\$)	8.25	10.00
G&A Cost Per Tonne Processed	(US\$)	1.00	0.32
Process Recoveries			
Gold Process Recovery	(%)	70.0%	89.2%
Silver Process Recovery	(%)	75.0%	75.8%
NSR Factor for Gold	(US\$)	36.01	34.41
NSR Factor for Silver	(US\$)	0.482	0.468
Breakeven NSR Cutoff	(US\$)	11.25	11.72
Internal NSR Cutoff	(US\$)	9.25	10.32
Silver Equivalent Divisor	(none)	74.67	73.55
Breakeven Gold Eq Cutoff Grade	(g/t)	0.31	0.34
Internal Gold Eq Cutoff Grade	(g/t)	0.26	0.30

15 MINERAL RESERVE ESTIMATES

No Mineral Reserves have been estimated for the Metates Sulphide Heap Leach Project - Phase 1.

16 MINING METHODS

16.1 OPERATING PARAMETERS AND CRITERIA

The Metates mine will be a conventional open pit mine. Mine operations will consist of drilling holes with medium diameter (approximately 20.3 cm) blast holes, blasting with emulsions and ANFO (ammonium nitrate/fuel oil) depending on water conditions, and loading plant feed into large off-road trucks with hydraulic shovels and wheel loaders. Plant feed will be delivered to the primary crusher, and waste will be delivered to various waste storage facilities. The Metates mineral resource is broadly divided into intrusive-hosted and sedimentary-hosted rock types. The mine plan for this study only considered the intrusive-hosted mineralization as potential plant feed. There will be a stockpile for sedimentary-hosted resource that is not considered plant feed for this first phase of the operation. There will also be a low-grade stockpile facility to store marginal-grade intrusive material for processing at the end of commercial pit operations. There will be a fleet of track dozers, rubber-tired dozers, motor graders, and water trucks to maintain the working areas of the pit, waste storage areas, and haul roads.

A mine plan was developed to supply plant feed to a crushing plant with the capacity to process 15,000 tonnes per day (tpd) (5,475 kilotonnes per year [ktpy]). After crushing, the material is placed on a pad to allow it to oxidize after which it is transferred to a permanent pad for cyanide leaching.

The mine is scheduled to operate two 12-hour shifts per day for 365 days per year.

16.2 PIT SLOPE ANGLES

Pit slope angles for mine design were developed by Call & Nicholas, Inc. (CNI) of Tucson, Arizona and are reported in "Prefeasibility Slope Angles for Metates Deposit," dated December 2012. The design recommendations are complex and are based on lithology and orientation (dip direction) of the pit wall as shown in Table 16-1 and Figure 16-1. The recommended angles are based on trim row/buffer row blasting on the final walls.

Table 16-1: Recommended Slope Angles, CNI 2012

Wall DDR	Structural Domains									Wall DDR
	SW Sediments	Trough Sediments	NE Sediments	Conglomerate	North Sediments	Andesite	Rhyolite	Intrusive	Quaternary Alluvium	
0										0
10	39°									10
20										20
30			48°							30
40		44°				48°		47°		40
50	37°									50
60										60
70										70
80										80
90										90
100	48°									100
110										110
120		48°								120
130										130
140										140
150										150
160										160
170										170
180							48°		28° & 15 m Step at Base	180
190										190
200										200
210										210
220		42°	42°					48°		220
230										230
240										240
250				48°	48°					250
260										260
270						48°				270
280										280
290		48°								290
300										300
310										310
320			48°							320
330										330
340	39°	44°								340
350										350
360										360

**METATES SULPHIDE HEAP LEACH PROJECT - PHASE 1
FORM 43-101F1 TECHNICAL REPORT**

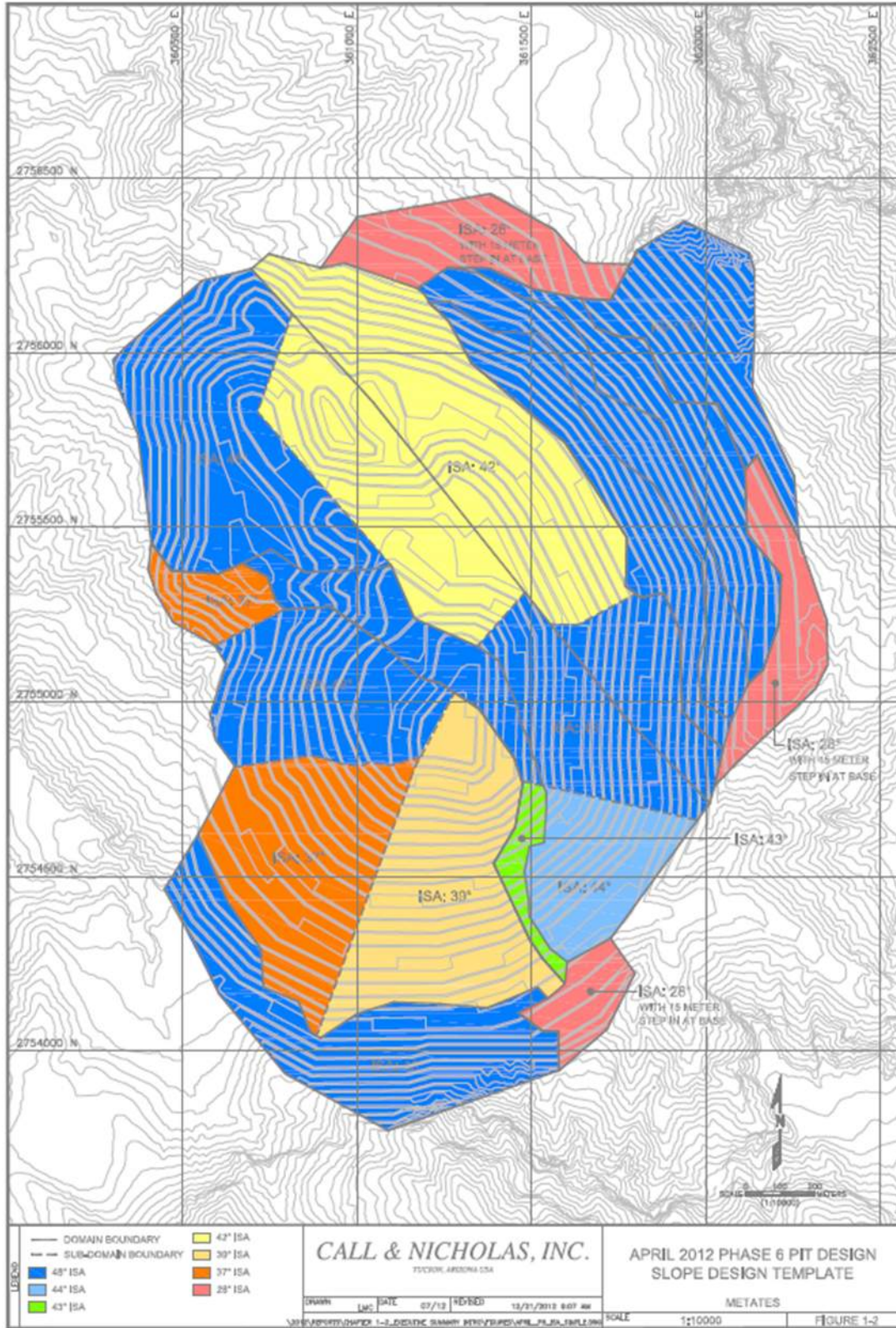

Figure 16-1: Inter-ramp Slope Angles, CNI 2012

16.3 ECONOMIC PARAMETERS

Table 16-2 shows the prices, unit costs and recovery parameters used for the mine design. The gold and silver prices of US\$ 1600 and US\$ 20 per ounce respectively are reasonable based on current spot prices. The plant recoveries of 70% for gold and 75% for silver were provided by M3 based on initial estimates. The unit processing cost of US\$ 8.25 was also provided by M3 and is based on a plant production rate of 15,000 tpd (5,475 ktpy). M3 estimated a G&A cost of US\$ 11 million per year, which amounts to US\$ 2.00 per plant tonne. The mining cost is a preliminary estimate by IMC based on recent studies conducted in Mexico.

Table 16-2: Economic Parameters for Mine Design

Parameter/Case	Units	
Gold Price Per Ounce	(US\$)	1600
Silver Price Per Ounce	(US\$)	20.00
Mining Cost Per Total Tonne	(US\$)	2.00
Process Cost Per Plant Tonne	(US\$)	8.25
G&A Cost Per Plant Tonne	(US\$)	2.00
Process Recoveries		
Gold Process Recovery	(%)	70.0%
Silver Process Recovery	(%)	75.0%
NSR Factor for Gold	(US\$)	36.01
NSR Factor for Silver	(US\$)	0.482
Breakeven NSR Cutoff	(US\$)	12.25
Internal NSR Cutoff	(US\$)	10.25
Silver Equivalent Divisor	(none)	74.67
Breakeven Gold Eq Cutoff Grade	(g/t)	0.34
Internal Gold Eq Cutoff Grade	(g/t)	0.28

Considering the gold and silver prices and recovery estimates, a gold equivalent value was calculated for the model blocks to classify material into potential resource and waste:

$$\text{Gold Equivalent (g/t)} = \text{Gold (g/t)} + \text{Silver (g/t)} / 74.67$$

Note that,

$$\text{NSR Gold} = \$1600 \times 0.70 \times \text{Gold (g/t)} / 31.103 = \$36.01 \times \text{Gold (g/t)}$$

$$\text{NSR Silver} = \$20 \times 0.75 \times \text{Silver (g/t)} / 31.103 = \$0.482 \times \text{Silver (g/t)}$$

And the silver divisor is:

$$\text{Silver Divisor} = \$36.01 / \$0.482 = 74.67$$

Internal and breakeven cut-offs are 0.28 g/t and 0.34 g/t gold equivalent, respectively. Internal cut-off grade applies to blocks that must be removed from the pit such that mining cost is considered a sunk cost. This typically defines the minimum cut-off grade used for production scheduling.

16.4 MINING PHASES

The mine production schedule is based on four mining phases developed by IMC during March and April 2021. The phases are based on 25 m wide roads at a maximum grade of 10% and adequate working room for equipment. The road width is adequate for trucks of the 90 mt class, such as Caterpillar 777 trucks.

METATES SULPHIDE HEAP LEACH PROJECT - PHASE 1
FORM 43-101F1 TECHNICAL REPORT

Phases 1 and 2 (Figure 16-2 and Figure 16-3) are north of the San Nicholas drainage so it is not impacted by initial mining.

Mining phase 3 (Figure 16-4) is mined in three parts. Phase 3A is south of the San Nicholas drainage and mines to the final pit limits on the south side of the pit, down to the drainage level. Phase 3B is north of San Nicholas and mines down to the drainage level. Phase 3C continues mining the pit to depth as shown on the figure.

Phase 4 (Figure 16-5) goes to final pit limits on the north side.

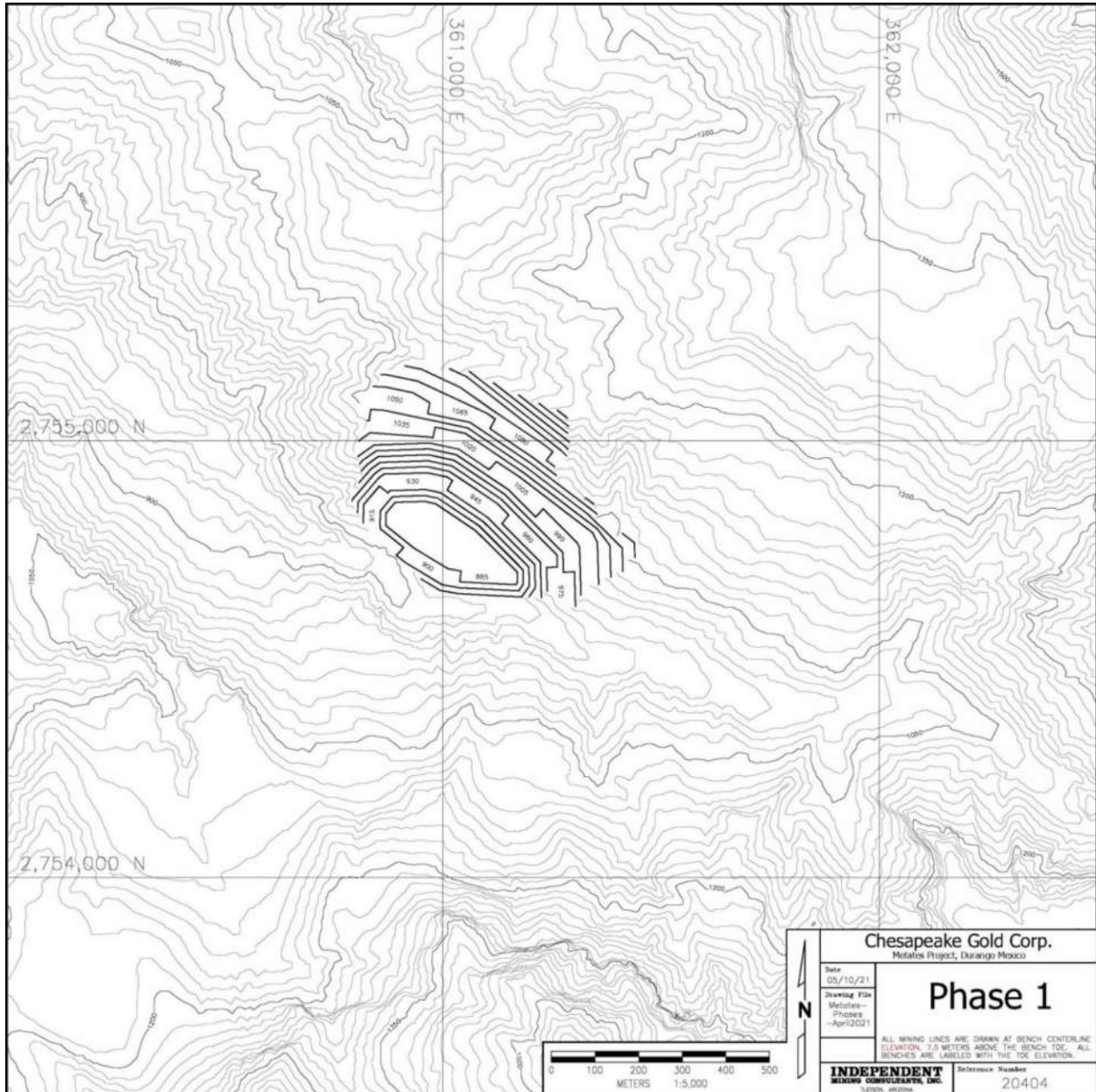

Figure 16-2: Mining Phase 1, IMC 2021

**METATES SULPHIDE HEAP LEACH PROJECT - PHASE 1
FORM 43-101F1 TECHNICAL REPORT**

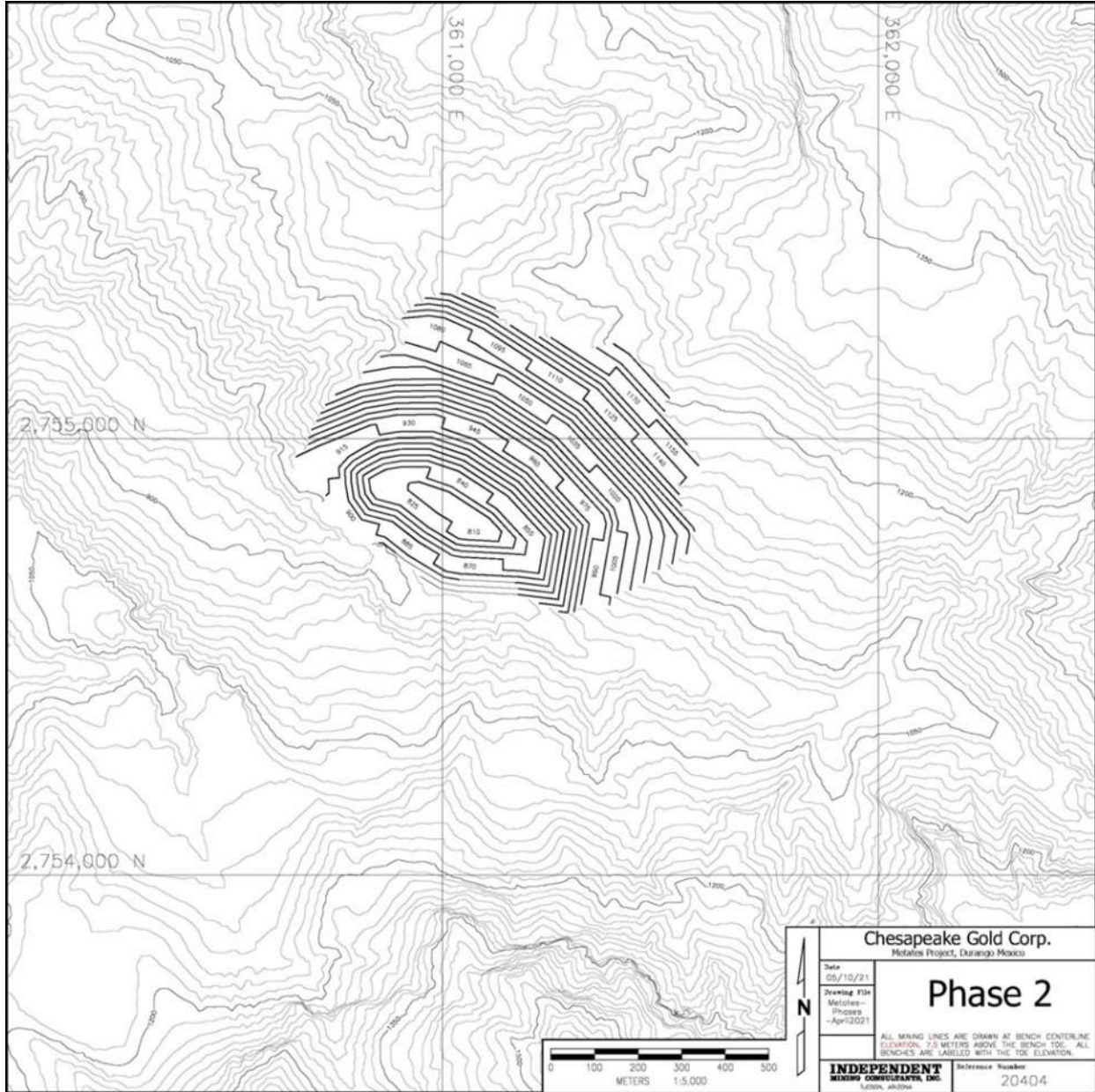

Figure 16-3: Mining Phase 2, IMC 2021

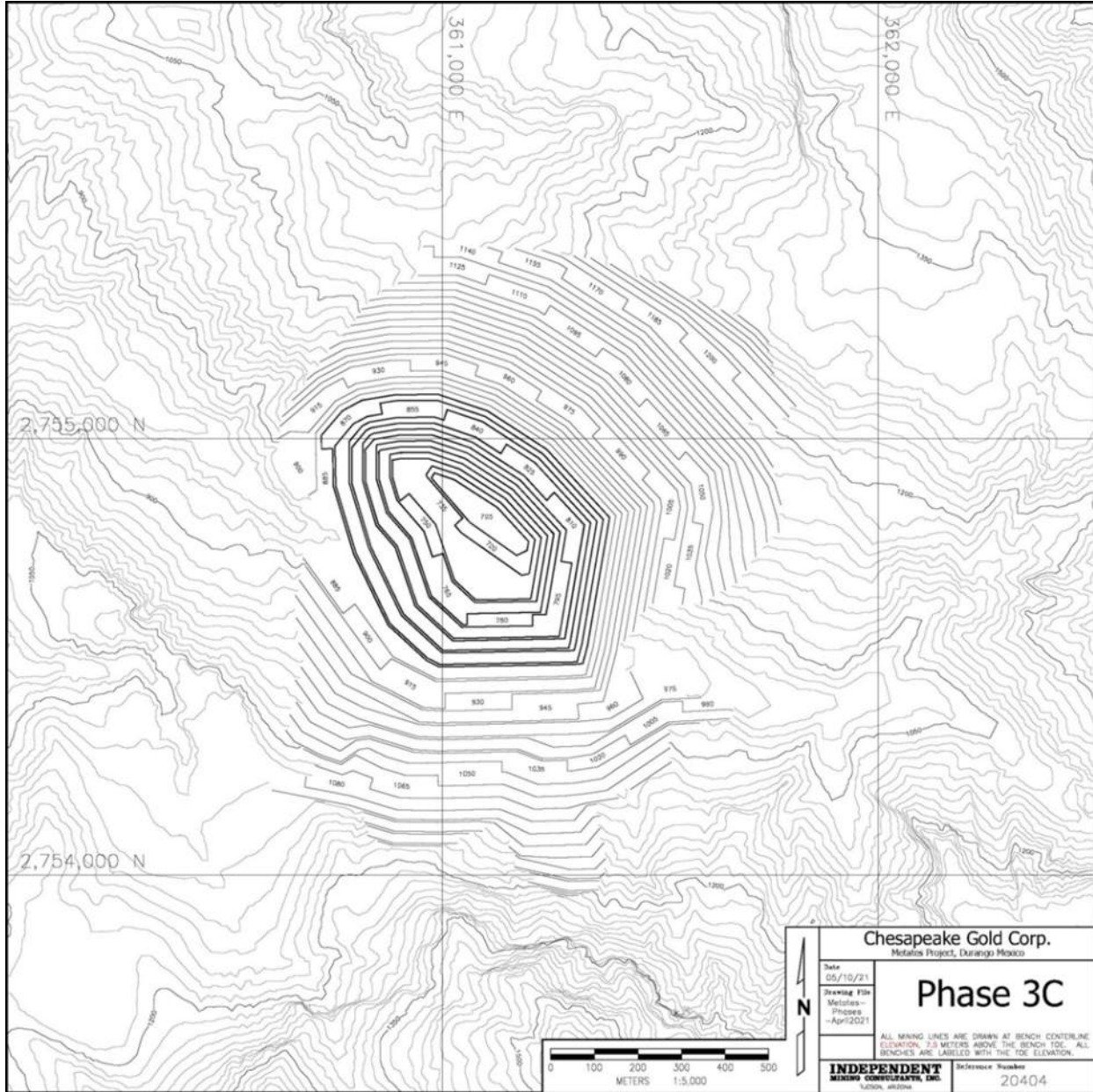

Figure 16-4: Mining Phase 3, IMC 2021

**METATES SULPHIDE HEAP LEACH PROJECT - PHASE 1
FORM 43-101F1 TECHNICAL REPORT**

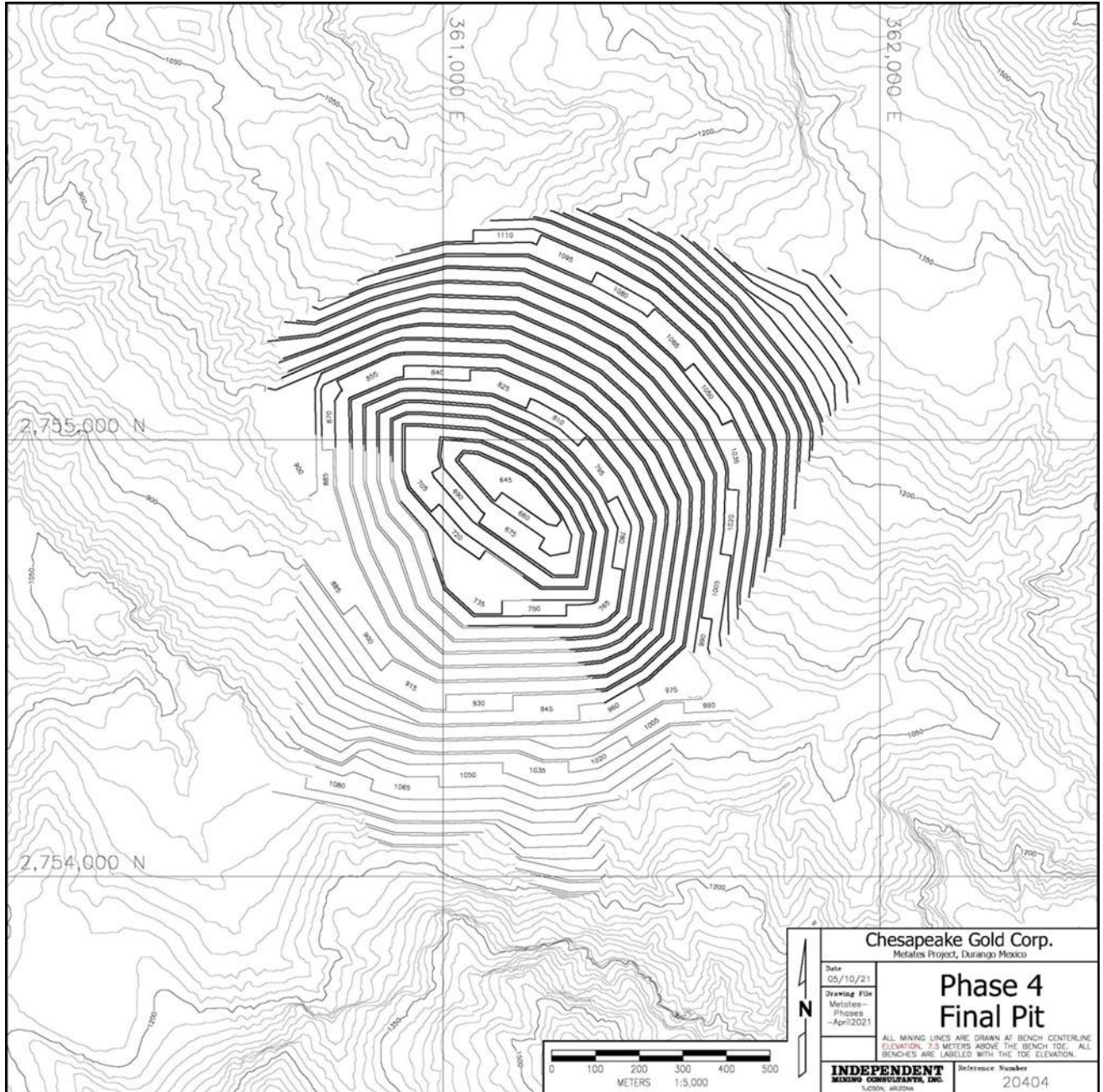

Figure 16-5: Metates Final Pit (Phase 4), IMC 2021

16.5 MINE PRODUCTION SCHEDULE

The mine production schedule is based on supplying 15,000 tpd, or 5,475 ktpy of material to the primary crusher. Table 16-3 shows the mining schedule by years. The upper section of the table shows direct process feed by time period. This is material that is processed the same year it is mined. This amounts to 127.3 Mt at 0.872 g/t gold and 15.93 g/t silver, which equates to 1.086 g/t gold equivalent. This contains about 3.57 Moz of gold and 65.2 Moz of silver. As previously discussed, a gold equivalent cut-off was used to classify resource and waste for scheduling. The gold equivalent cut-off varies by period to balance the mine and plant production capacities. The cut-off ranges from a high of 0.90 g/t during Year 2 to a low of 0.28 g/t, internal cut-off, during Years 18 through 24. The mine production schedule shows 5,475 ktpy of direct feed mined during Years 2 through 23.

Low-grade material is between a gold equivalent cut-off of 0.33 g/t and the operating cut-off grade for the year. This amounts to 38.8 Mt at 0.374 g/t gold and 14.99 g/t silver over the life-of-mine plan. This contains 466,100 ounces of gold and 18.7 Moz of silver. The low-grade stockpile cut-off of 0.33 g/t gold equivalent includes an allowance of about US\$ 1.50/t for rehandle costs.

The third section of the table shows gold- and silver-bearing sedimentary resource that is mined and stockpiled each year. This material amounts to 207.4 Mt at 0.398 g/t gold and 18.39 g/t silver over the life of the mine. This material is tabulated at a gold equivalent cut-off of 0.30 g/t.

The bottom of Table 16-3 shows that preproduction is 5.16 Mt of total material. Total production ramps up during Years 1 through 3 to reach a peak material rate of 30 Mt per year for Years 4 through 17. Total material is 534.0 Mt. Waste, net of the low grade, is 367.9 Mt. With low grade included as resource, the average waste ratio is 2.22 to 1.

Table 16-4 shows a proposed plant production schedule. Year 1 plant production is 5.0 Mt, about 91% of plant capacity, and is made up of mineralized material mined during preproduction and Year 1. The low-grade stockpile material is processed during Years 24 through 31. Total mineral resource processed is 166.1 Mt at 0.756 g/t gold and 15.71 g/t silver. This amounts to 4.04 Moz of contained gold and 83.9 Moz of contained silver.

Only measured and indicated mineral resource is considered for this study. Inferred intrusive mineral resource in the pit is only half a million tonnes and is treated as waste. However, this PEA is preliminary in nature and there is no guarantee that the results of the PEA will be realized or that the mineral resources will be upgraded to mineral reserves.

The mine plan for this study only considered the intrusive hosted mineralization as potential plant feed. It is higher grade material and the metallurgical characteristics are better defined than the sedimentary hosted mineralization. However, the mineralized sediments mined in the schedule are tabulated and stockpiled for future consideration.

The mine production schedule includes allowances for mining dilution and mineralized material loss. IMC believes that reasonable amounts of dilution and loss were incorporated into the block model used for this Technical Report. Compositing assays into composites and estimating blocks with multiple composites introduces some smoothing of model grades that are analogous to dilution and mineralized material loss effects.

Table 16-4: Plant Production Schedule

PLANT PRODUCTION SCHEDULE:	(Units)	TOTAL	Year 1	Year 2	Year 3	Year 4	Year 5	Year 6	Year 7	Year 8	Year 9	Year 10	Year 11	Year 12	Year 13	Year 14	Year 15	Year 16
TOTAL PLANT FEED:																		
Gold Equivalent Cutoff	(g/t)		0.75	0.90	0.76	0.76	0.72	0.75	0.70	0.62	0.62	0.85	0.80	0.76	0.80	0.70	0.70	0.66
Ktonnes	(kt)	166,091	5,000	5,475	5,475	5,475	5,475	5,475	5,475	5,475	5,475	5,475	5,475	5,475	5,475	5,475	5,474	5,475
Gold Equivalent	(g/t)	0.966	1.231	1.257	1.210	1.218	1.032	1.089	1.307	1.321	0.926	1.103	1.205	1.247	1.265	1.146	1.079	1.017
Gold	(g/t)	0.756	0.356	0.680	0.852	0.983	0.812	0.886	1.126	1.177	0.745	0.925	1.034	1.078	1.109	1.009	0.957	0.913
Silver	(g/t)	15.71	65.38	43.08	26.78	17.50	16.41	15.16	13.47	10.74	13.61	13.35	12.70	12.60	11.65	10.24	9.09	7.75
Zinc	(%)	0.291	0.519	0.570	0.437	0.270	0.422	0.409	0.237	0.178	0.404	0.273	0.243	0.218	0.185	0.178	0.148	0.119
Copper	(%)	0.013	0.006	0.012	0.015	0.015	0.011	0.014	0.017	0.017	0.009	0.014	0.015	0.015	0.016	0.016	0.017	0.019
Sulphur	(%)	5.52	3.69	5.65	6.33	6.50	5.95	6.43	7.11	6.95	5.43	6.21	6.56	6.66	6.74	6.40	6.16	5.93
Contained Gold	(koz)	4,035.7	57.2	119.7	149.9	173.1	142.9	156.0	198.3	207.2	131.1	162.8	182.1	189.7	195.2	177.7	168.5	160.7
Payable Gold@	70% (koz)	2,825.0	40.0	83.8	104.9	121.2	100.0	109.2	138.8	145.1	91.7	114.0	127.5	132.8	136.6	124.4	117.9	112.5
Contained Silver	(koz)	83,888	10,511	7,584	4,714	3,080	2,888	2,669	2,371	1,891	2,395	2,350	2,235	2,218	2,050	1,802	1,600	1,364
Payable Silver@	75% (koz)	62,916	7,883	5,688	3,536	2,310	2,166	2,002	1,778	1,418	1,796	1,762	1,676	1,663	1,538	1,352	1,200	1,023

PLANT PRODUCTION SCHEDULE:	(Units)	TOTAL	Year 17	Year 18	Year 19	Year 20	Year 21	Year 22	Year 23	Year 24	Year 25	Year 26	Year 27	Year 28	Year 29	Year 30	Year 31
TOTAL PLANT FEED:																	
Gold Equivalent Cutoff	(g/t)		0.66	0.28	0.28	0.28	0.28	0.28	0.28	0.28	0.33	0.33	0.33	0.33	0.33	0.33	0.33
Ktonnes	(kt)	166,091	5,475	5,475	5,475	5,475	5,475	5,475	5,475	5,475	5,475	5,475	5,475	5,475	5,475	5,475	2,317
Gold Equivalent	(g/t)	0.966	1.045	0.988	0.944	0.882	0.832	0.808	0.894	0.661	0.604	0.601	0.578	0.517	0.530	0.638	0.574
Gold	(g/t)	0.756	0.898	0.800	0.782	0.734	0.705	0.701	0.786	0.550	0.472	0.420	0.383	0.323	0.351	0.338	0.178
Silver	(g/t)	15.71	10.96	14.08	12.11	11.06	9.50	8.05	8.09	8.25	9.84	13.51	14.51	14.51	13.35	22.39	29.59
Zinc	(%)	0.291	0.147	0.168	0.165	0.159	0.126	0.108	0.113	0.191	0.378	0.474	0.459	0.518	0.460	0.441	0.336
Copper	(%)	0.013	0.017	0.014	0.014	0.016	0.016	0.017	0.017	0.013	0.010	0.007	0.007	0.007	0.008	0.007	0.004
Sulphur	(%)	5.52	5.87	5.60	5.60	5.49	5.45	5.39	5.42	4.66	4.59	4.34	4.12	3.78	3.94	3.79	2.58
Contained Gold	(koz)	4,035.7	158.1	140.8	137.6	129.2	124.0	123.3	138.3	96.8	83.0	73.9	67.5	56.8	61.8	59.5	13.2
Payable Gold@	70% (koz)	2,825.0	110.7	98.5	96.3	90.4	86.8	86.3	96.8	67.7	58.1	51.7	47.2	39.8	43.2	41.7	9.3
Contained Silver	(koz)	83,888	1,929	2,478	2,132	1,947	1,673	1,418	1,424	1,452	1,733	2,378	2,553	2,555	2,350	3,941	2,205
Payable Silver@	75% (koz)	62,916	1,447	1,858	1,599	1,460	1,255	1,063	1,068	1,089	1,300	1,784	1,915	1,916	1,763	2,955	1,653

16.6 WASTE STORAGE AND STOCKPILES

Figure 16-6 shows the final pit and the various waste storage areas and stockpiles. These include the following:

- The sediment resource stockpile, north of the pit, contains of 207.4 Mt at 0.40 g/t gold and 18.4 g/t silver. This is 2.65 Moz of contained gold and 122.6 Moz of contained silver.
- The non-acid generating (NAG) waste storage area east of the pit contains 42.9 Mt. This facility contains the post mineral volcanic rocks.
- The potentially acid generating (PAG) waste storage area northwest of the pit contains 117.6 Mt. This is composed of mine waste in intrusive and sedimentary rock, other than the sedimentary resource stockpile.
- The low-grade stockpile, north of the sedimentary resource stockpile, contains 38.9 Mt at 0.37 g/t gold and 15.0 g/t silver. This is 466,100 ounces of contained gold and 18.7 Moz of contained silver. This material is low grade intrusive hosted mineralization.

The PAG and NAG waste storage areas, and the sedimentary resource stockpile, are developed in 30-m lifts at its angle of repose (37°). There is a 35-m setback between lifts so the overall slope angle is 2.5H:1V, about 22°. It is anticipated that this is flat enough to make closure easier.

The low-grade stockpile is at its angle of repose as it is not anticipated that it will be a permanent facility.

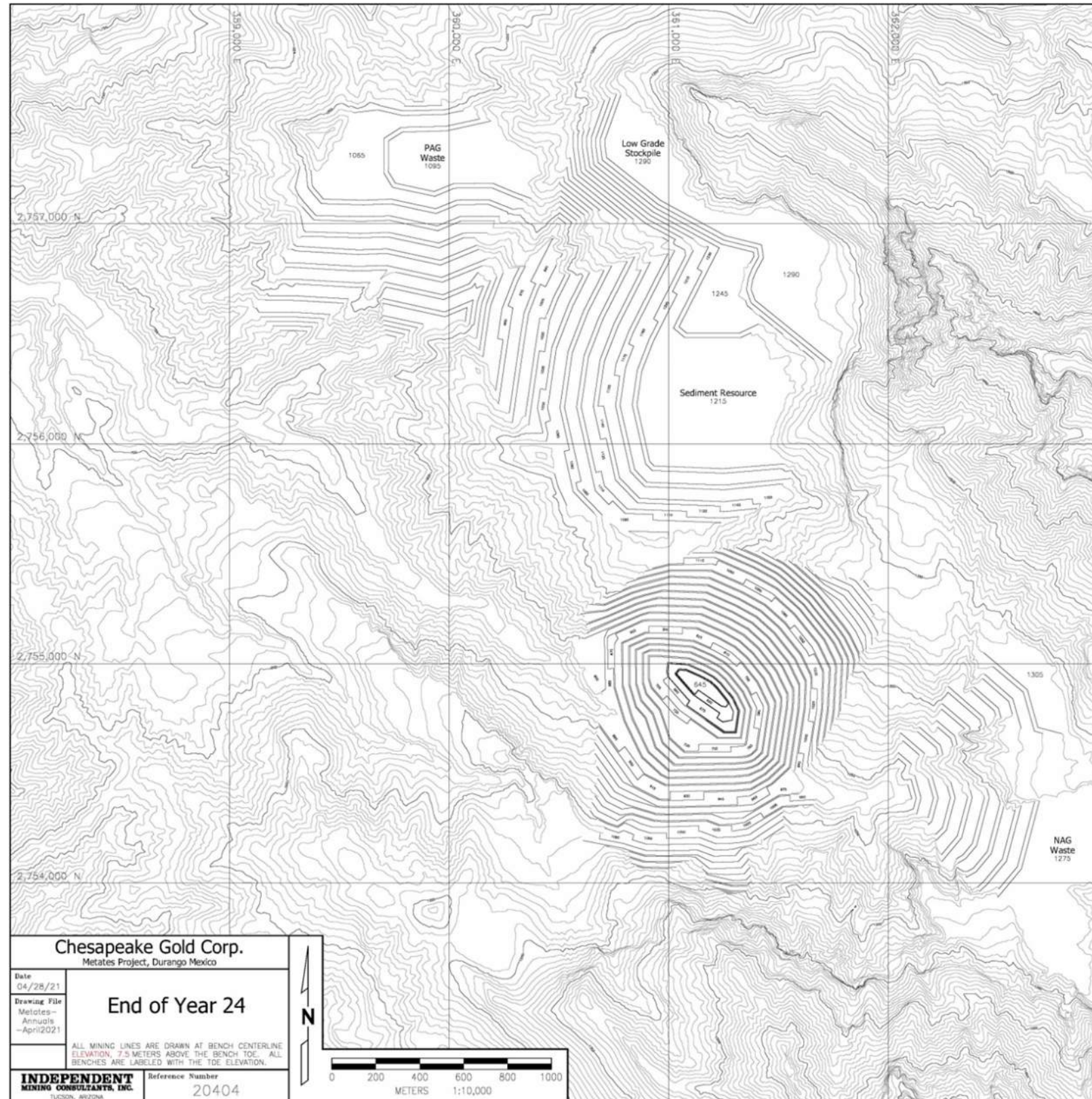

Figure 16-6: Waste Storage Areas and Stockpiles, IMC 2021

16.7 MINING EQUIPMENT

Mine major equipment requirements for the Metates mine were sized and estimated using first principles and based on the mine production schedule, the mine work schedule, and estimated equipment productivity rates. The work schedule is based on two 12-hour shifts per day for 365 days per year. The mine equipment estimate is based on owner operation and assumes a well-managed mining operation with a well-trained labor pool and that all the equipment is new at the start of mining.

Table 16-5 shows major equipment requirements by time period for Metates. The equipment required for preproduction, Year 1, and the peak number of units is shown. This represents the equipment required to perform the following duties:

- Developing access roads from the mine to the crusher, low-grade stockpile, sediment resource stockpile, and the NAG and PAG waste storage areas.
- Mining and transporting leach resource to the crusher or low-grade stockpile.
- Mining and transporting sediment resource to the sediment stockpile.
- Mining and transporting NAG and PAG waste to the appropriate waste storage areas.
- Maintaining the haul roads and various storage areas.

Table 16-5: Mining Equipment

Equipment Type	Capacity/Power	PP	Year 1	Peak
Caterpillar MD6250 Drill	(203 mm)	1	2	3
Caterpillar 6030FS Hyd Shovel	(16.5 m ³)	0	1	3
Caterpillar 992K Wheel Loader	(11.5 m ³)	1	1	1
Caterpillar 777G Truck	(91 t)	4	10	29
Caterpillar D10T2 Track Dozer	(447 kW)	1	2	3
Caterpillar D9T Track Dozer	(325 kW)	1	2	3
Caterpillar 834K Wheel Dozer	(370 kW)	1	1	2
Caterpillar 16M3 Motor Grader	(216 kW)	1	2	2
Water Truck - 18,000 gal	(68,100 l)	1	2	2
Caterpillar 345FL Excavator	(3.2 m ³)	1	1	1
Sandvik DI560 DTH Drill	(127 mm)	2	2	2
TOTAL		14	26	51

The peak equipment fleet consists of:

- Three rotary blast hole drills capable of drilling 203-mm (8-inch) diameter holes.
- Three hydraulic shovels with 16.5-cubic meter (m³) bucket capacity.
- One wheel loader with 11.5-m³ bucket capacity.
- Trucks of 91-t capacity. A fleet of 29 trucks is required.
- Three track dozers of the Caterpillar D10 class (447 kW) and three track dozers of the Caterpillar D9 class (325 kW).
- Two-wheel dozers (370 kW).
- Two motor graders and two water trucks.
- One small excavator.
- And two small drills for pioneering, pre-splitting, etc.

METATES SULPHIDE HEAP LEACH PROJECT - PHASE 1
FORM 43-101F1 TECHNICAL REPORT

Concerning the truck fleet, the following is noted. A fleet of 29 trucks will accommodate most years, but there is a peak of 32 to 41 trucks from Years 15 to 17. For costing purposes, IMC has assumed the purchase of 29 trucks and short-term leases to cover the peak years. Revising the production schedule to smooth this peak will be examined in the next study.

The mine capital cost estimate will include an allowance for small equipment such as fuel and lubricant trucks, mechanic and welding trucks, tire handlers, lowboy trailers and tractors to transport track equipment, cranes, surveying and engineering equipment. This might also include pumps for dewatering. The mine operating cost estimate will include an allowance for mine services which includes the cost of running the small equipment. This could also include pumping equipment.

The specifications for mine infrastructure such as the shop and warehouse, fuel and lubricant facilities, explosive storage facilities, and offices is included in the scope of the general infrastructure contractor.

17 RECOVERY METHODS

The planned Metates Sulphide Heap Leach Project - Phase 1 heap leach operation has a nominal capacity of 15,000 tpd at an overall availability of 90%.

The overall processing scheme would be to crush the material to 80% finer than ½ inch or (P₈₀) 13 mm, oxidize it on an on-off pad and leach it with cyanide on a dedicated pad.

A simplified flow sheet of the Metates process is shown in Figure 17-1. Detailed flow sheets and general arrangement drawings are available from Chesapeake. The overall site layout is shown in Figure 17-2.

17.1 OXIDATION PAD OPERATIONS

17.1.1 Crushing

The Metates crushing plant will comprise three stages of crushing, starting with a jaw crusher for primary crushing, followed by a standard cone crusher for secondary crushing, and finally a short-head cone crusher for tertiary crushing. Table 17-1 below is a list of the major equipment in the crushing plant.

Table 17-1: List of Main Crushing Plant Equipment

Equipment	Number	Description	Installed kW
Primary Dump Pocket	1	Feed Bin for Primary Crusher, 3-truckload capacity	0
Primary Crusher Feeder	1	Variable speed apron feeder	37
Vibrating Grizzly	1	Metso VG645-3V or equivalent, 130 mm opening	37
Primary Crusher	1	Metso C150 or equivalent	200
Secondary Crusher	1	Metso MP800, standard, CSS = 30 mm	600
Tertiary Crusher	1	Metso MP800, short head, CSS = 20 mm	600
Secondary Screen	1	Double-deck banana screen, 2.445 x 6.1 m, 63 mm and 20 mm opening	37
Tertiary Screen	1	Double-deck banana screen, 2.445 x 6.1 m, 30 mm and 20 mm opening	37
Oxidation Mixing Drum	1	2.74 m diameter x 9.15 m long (9 ft x 30 ft)	112

Mine trucks deliver run-of-mine (ROM) material to the primary crushing plant directly into the crusher dump pockets or to a temporary stockpile near the crusher. The dump pocket is designed to hold three truckloads of material (273 tonnes) that will be discharged at a controlled rate by an apron feeder to a vibrating grizzly feeder, which is set at 130 mm opening. Oversize from the vibrating grizzly proceeds to the primary crusher while the undersize bypasses to the primary crusher product conveyor.

The primary crushing plant consists of a single jaw crusher operating with a discharge set at 130 mm (5 inches). The crushed product will drop to the primary crusher product conveyor, mixing with the grizzly undersize. At this point, the combined material is estimated to have a nominal size distribution of about 80% finer than (P₈₀)128 mm. The size of the crushed product will vary with the type of material, the degree of fragmentation in the mine, and the percentage of fines in the feed.

Material from the primary crusher will be conveyed to a double-deck secondary crusher screen to remove -20 mm materials, which is conveyed to the final crushed product. The screen oversize is fed to the secondary crusher, which is set at a close side setting (CSS) of 30 mm.

METATES SULPHIDE HEAP LEACH PROJECT - PHASE 1
FORM 43-101F1 TECHNICAL REPORT

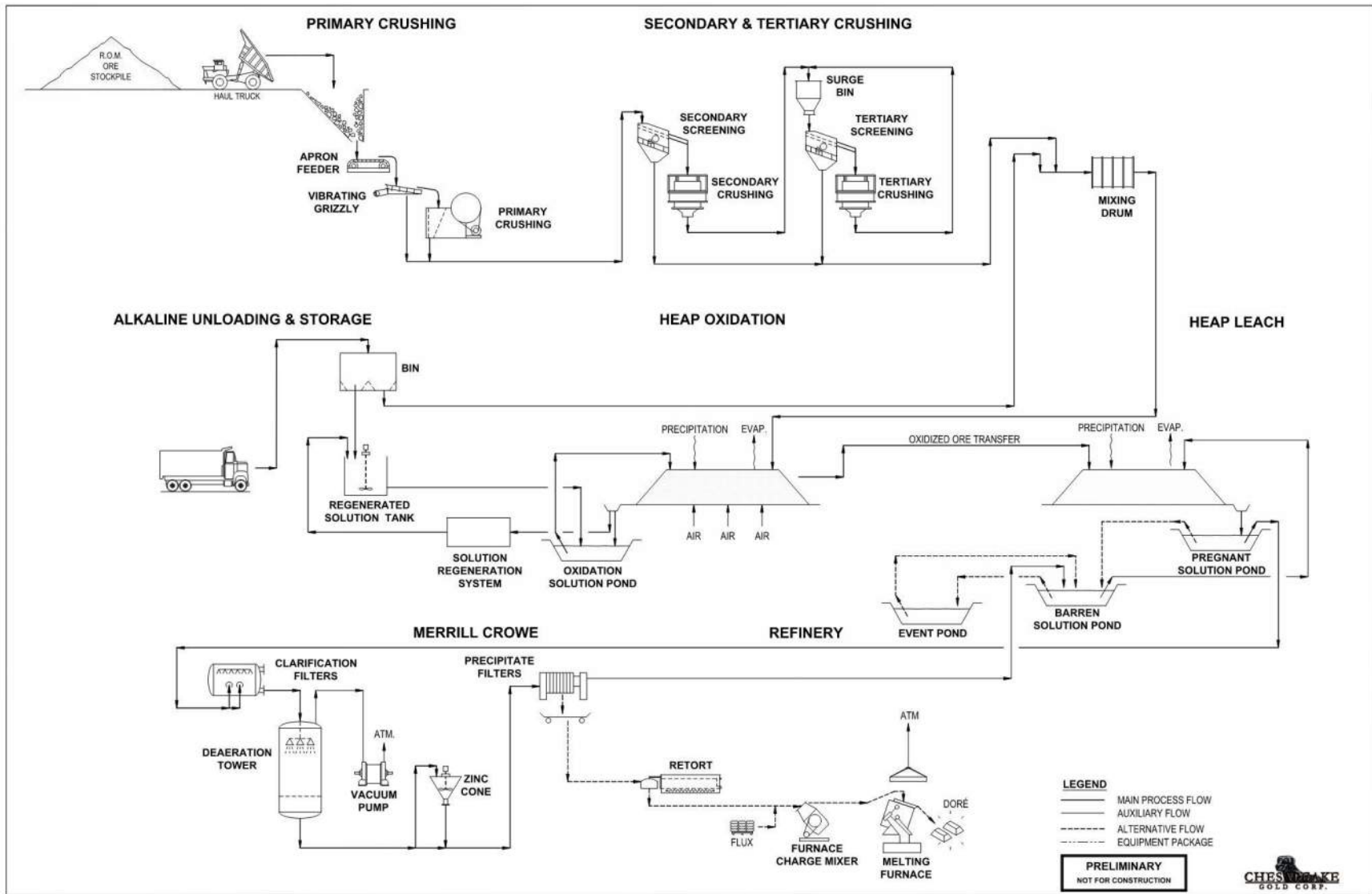

Figure 17-1: Simplified Flow Sheet of the Metates Sulphide Heap Leach Project

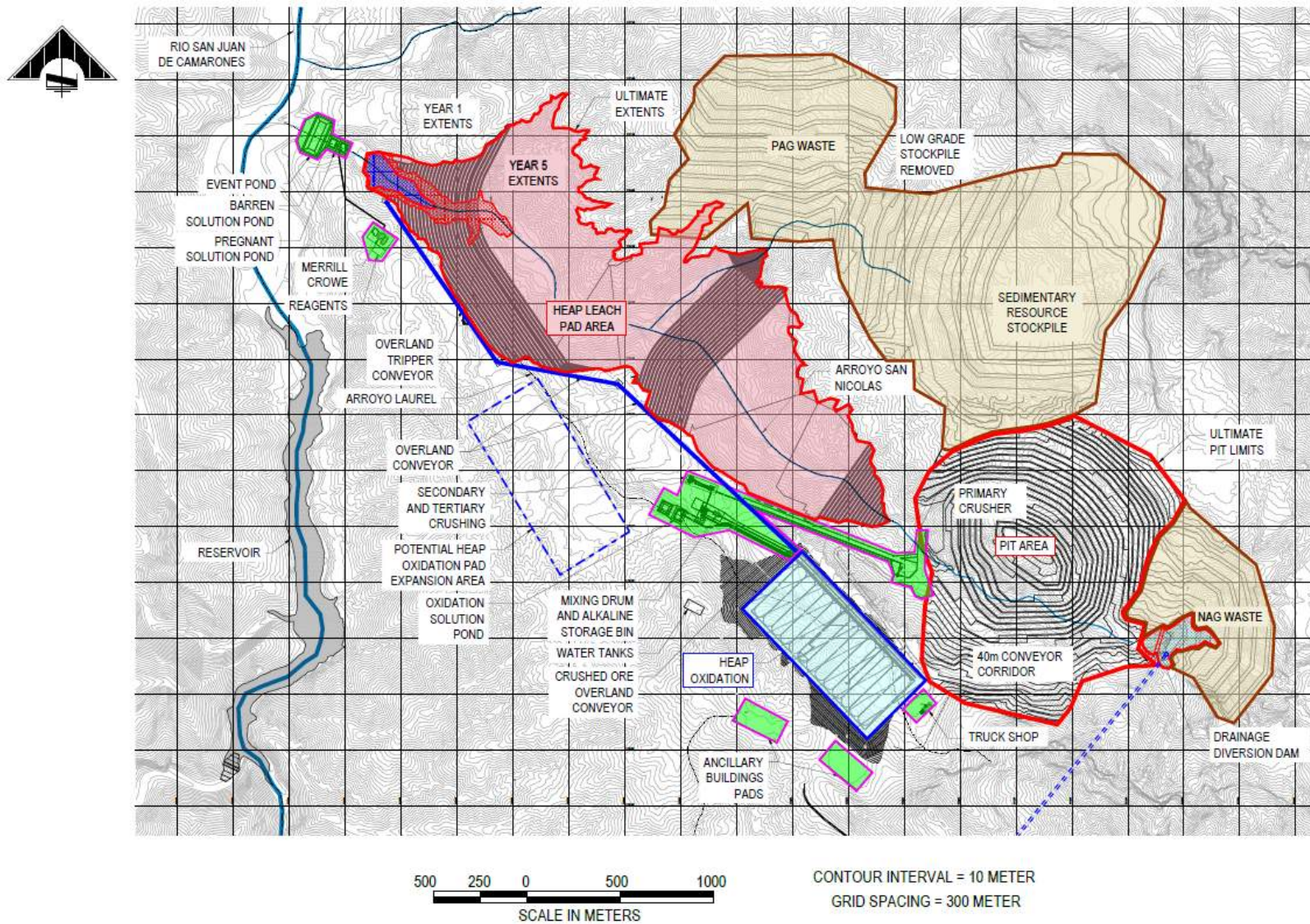

Figure 17-2: General Arrangement of Open Pit, Stockpile and Waste Rock Dumps and Process Facilities

The secondary crushed material is conveyed to the double-deck tertiary screen, which also removes the -20 mm material and sends it to the final crushed product. The oversize of the screen proceeds to the tertiary crusher, which is set at a CSS of 20 mm. The tertiary crusher product is then conveyed back to the tertiary screen to form a closed loop.

The final crushed product is targeted to have a P_{80} of 13 mm. This will be fed to a rotating-drum mixer where alkaline solution will be added and thoroughly mixed into the crushed material. From here, the material will be transferred to the oxidation pad through a series of overland and grasshopper conveyors and a stacker.

17.1.2 Oxidation On-Off Pad

Oxidation of the mined and crushed material will be conducted on an on-off pad, as shown in Figure 17-2. It is 438 m wide and 961 m long, which includes access corridors. The pad useable area for actual stacking is 360 m wide and 871 m long, for a total useable area of 31.4 hectares. The pad is lined with HDPE and a 1-m layer of permeable aggregate as liner cover. Aeration lines will be imbedded in the liner cover set above the phreatic level of the oxidation solution.

The oxidation pad will be divided into 13 cells along the length of the pad and separated with curbs that are built into the HDPE liner. One of the cells is always empty to serve as a buffer between the cell that is being stacked and the cell that is being emptied. Materials in each cell will spend from 90 to 180 days of the oxidation cycle, which will be described in more detail below.

Air blown under the oxidation pad will be supplied by two aeration blowers, one operating and one standby, each able to deliver 64,200 normal cubic meters per hour (Nm³/h) (40,000 standard cubic feet per minute [scfm]) of air at a pressure of 52 kilopascal (gauge) (kPa[g]) (7.5 pounds per square inch-guage [psig]) at the injection point.

17.1.3 Conveying, Stacking and Oxidized Material Retrieval

The major equipment used to load and unload the oxidation pad are listed in Table 17-2 below. From the mixing drum, the material is conveyed to the oxidation pad where it is transferred to a tripping conveyor that runs along the length of the oxidation pad. The tripper would be positioned at the cell currently being loaded where the material is transferred from the tripper discharge conveyor onto the first of a series of portable conveyors that ends at the stacking conveyor system. The material is spread onto the cell using a radial stacker to a height of 20 to 25 feet.

Table 17-2: List of Conveying and Stacking Equipment for the Oxidation Pad

Equipment	Number	Description	Drive, kW
Overland Tripper Conveyor	1	36" belt, 913 m (2996 ft) long, 53 m lift, 500 fpm	448
Mobile Tripper Discharge Conveyor	1	42" belt, 8 m (25 ft) long, 0 m lift, 500 fpm	22
Portable Conveyor	15	36" belt, 35 m (115 ft) long, 3 m lift, 500 fpm	37
Horizontal Feed Conveyor	1	36" belt, 27 m (90 ft) long, 4 m lift, 500 fpm	45
Horizontal Conveyor	1	36" belt, 42.6 m (140 ft) long, 0 m lift, 500 fpm	30
Cross Over Conveyor 1	1	36" belt, 30 m (98 ft) long, 4 m lift, 500 fpm	45
Cross Over Conveyor 2 (Standby)	1	36" belt, 30 m (98 ft) long, 4 m lift, 500 fpm	45
Oxidation Pad Radial Stacker	1	36" belt, 42.6 m (140 ft) long, 7 m lift, 500 fpm	56
Overland Reclaim Conveyor	1	36" belt, 913 m (2996 ft) long, 53 m drop, 500 fpm	448 regen
Mobile Hopper	1	Hopper for reclaimed oxidized ore	
Mobile Hopper Feeder	1	36" belt, 23 m (75 ft) long, 3 m lift, 100 fpm	56
Front End Loader	2	Caterpillar 986K-Class loader, 6 m ³ bucket, 44 tonnes net wt	

The oxidation heap irrigation system will be installed on top of the newly stacked heap. It will include header lines and drip emitters.

On the other side of the buffer cell, a cell has completed its oxidation, rinse and drain cycle. The material will be retrieved by two front end loaders to a mobile hopper feeder to a series of portable conveyors. The last portable conveyor sends the oxidized material to the reclaim overland conveyor via a cross over conveyor. There will be a total of 15 portable conveyors that are split between stacking and reclaiming as required.

The overland reclaim conveyor then takes the oxidized material to the dedicated leach pad. At the beginning of operations, this conveyor will have a drop of 53 m and will therefore regenerate some power.

17.1.4 Oxidation

Oxidation of sulphide sulphur contained in the material is achieved in a moist alkaline environment with oxygen as the ultimate source of oxidation potential. Air will be continuously replenished by active injection of air at the bottom of the oxidation heap. Alkali will also be replenished continuously or intermittently by irrigating alkaline solution at the top of the heap at rates dictated mainly by pH of the solution that drains out at the solution collection point and limited by the holding capacity of the material while maintaining heap permeability to air.

Sampling lysimeters will be installed in the oxidation heap to monitor oxygen level, pH, dissolved sulphur concentrations and possibly other parameters and evaluate the progress of the oxidation process.

The pH of the oxidation solutions coming from each cell will be monitored. Once the pH falls below a threshold pH, for example pH 9.5, solution from that cell will be diverted to the solution regeneration system. The rest of the solution (with pH above the threshold) will be recycled to the top the oxidation stacks through the oxidation solution pond.

From preliminary test results, oxidation occurs rapidly at the beginning of the oxidation cycle, slows down and tapers off towards the end of the cycle. This means that solution regeneration is expected to be needed more for cells that are in the early stages of the oxidation cycle.

The oxidation process may take from 90 to 180 days, depending on the material type being oxidized. Projections on oxidation times will be derived from testing of composites and variability samples and will be further refined from measurements during operations.

When the target oxidation is achieved, the material will be rinsed with raw water to remove as much acid and sulfate as possible and allowed to drain. The rinsed material will then be retrieved from the oxidation pad and conveyed to the dedicated leach pad for cyanide heap leaching. The rinse solution will proceed to solution regeneration.

17.1.5 Solution Regeneration

The process of regenerating oxidation solutions is currently proprietary. The process neutralizes acid produced by the oxidation reaction, thereby restoring the pH of the solution to at least 10.5 and at most 11.

Two agitated regeneration tanks are planned for the project. Precipitates formed during regeneration will be thickened in a high-rate thickener. About 85 to 90% of the thickener underflow will be recycled back to the regeneration tanks to provide seed for crystallization.

Disposal of the remainder of the thickener underflow will be determined when enough sample is produced during testing using the United States Environmental Protection Agency's (USEPA) synthetic precipitation leaching procedure (SPLP). Depending on its stability, the regeneration precipitates may be comingled with mine waste or stored in a separate lined storage facility.

17.2 CYANIDE HEAP LEACHING

Cyanide heap leaching of oxidized material will be conducted on a dedicated leach pad, which is currently designed as a valley-fill facility as shown in Figure 17-2. Stacking will start at the lowest point in the valley, which is the closest point to Rio San Juan de Camarones. The extent of the leach pad at the end of Years 1 and 5 are outlined in Figure 17-2.

Oxidized material would be transferred from the oxidation pad to the dedicated heap leach pad by a system of overland conveyors, portable conveyors, and a radial stacker. Table 17-3 is a list of equipment to move oxidized materials to the heap leach pad and build the leach pad lifts.

From the oxidation pad, the oxidized materials will be moved by two overland conveyors to an overland tripper conveyor along the heap lead pad. All three overland conveyors will be moving materials downhill, thus generating power during operations. From the tripper conveyor, material will be moved towards the radial stacker through a series of ramp-portable (19 units) and portable conveyors (12 units). The number of ramp-portable and portable conveyors in use at any one time would vary according to the current location of the stacking face. The planned lift height is 20 feet (6 meters), but the stacker would stack up to 25 feet (7.5 meters) to allow for slump from its own weight.

Table 17-3: List of Conveying and Stacking Equipment for the Dedicated Leach Pad

Equipment	Number	Description	Drive, kW
Overland Conveyor	1	36" belt, 1362 m (4469 ft) long, 214 m drop, 500 fpm	506 regen
Overland Conveyor	1	36" belt, 673 m (2208 ft) long, 76 m drop, 500 fpm	187 regen
Overland Tripper Conveyor	1	36" belt, 590 m (1936 ft) long, 20.5 m drop, 500 fpm	187 regen
Mobile Tripper Discharge Conveyor	1	42" belt, 7.6 m (25 ft) long, 3 m lift	22
Ramp Portable Conveyor	19	36" belt, 35 m (115 ft) long, 3 m lift, 500 fpm	45
Portable Conveyor	12	36" belt, 35 m (115 ft) long, 3 m lift, 500 fpm	45
Horizontal Feed Conveyor	1	36" belt, 27 m (90 ft) long, 4 m lift, 500 fpm	45
Horizontal Conveyor	1	36" belt, 42.6 m (140 ft) long, 0 m lift, 500 fpm	30
Heap Leach Pad Radial Stacker	1	36" belt, 42.6 m (140 ft) long, 7 m lift, 500 fpm	75

Header pipes and drip emitters will be installed on top of the heap to deliver barren cyanide solution to the material. The planned irrigation rate will be 10 liters per hour per square meter (L/h/m²), for up to 60 days of primary leach. Cyanide concentration will be from 1 to 1.5 kg/tonne of solution. Pregnant solution will collect at the bottom of the heap and flow by gravity to the pregnant solution pond, from where it will be pumped to the Merrill-Crowe plant.

17.3 GOLD AND SILVER RECOVERY BY MERRILL-CROWE AND REFINERY

A conventional Merrill-Crowe zinc cementation plant is included in the design to recover gold and silver from the pregnant leach solution. The plant has a design capacity of 680 cubic meters per hour (m³/h) (3,000 gallons per minute [gpm]) of pregnant solution.

Pregnant solution first passes through a clarifying filter, then pumped to a deaerator tower to remove as much oxygen from the solution as possible. From here, the solution goes to a zinc mixing cone where the cementation reaction starts as soon as the solution contacts the zinc dust and continues as the solution and zinc dust are pumped to the pressure filter.

Gold and silver precipitates collected by the filter presses are dried in a retort to remove moisture and mercury before they are fluxed and smelted in a natural gas-fired melting furnace. At the end of smelting, molten metal is poured into bullion molds to produce the final plant product, doré bars, which are packed for shipment.

17.4 REAGENTS

The main reagents used in the oxidation and leach processes are lime, soda ash, and sodium cyanide. The Merrill-Crowe process uses reagents that are standard in typical Merrill-Crowe operations. A summary of the reagents projected to be used in this project is presented in Table 17-4.

The milk-of-lime (MOL) system consists of a lime slaker and MOL distribution tank. Pebble lime will be stored in a silo and metered into a vertical grinding mill by a screw feeder. The MOL produced is then pumped to a 4.9-m diameter by 4.9-m high MOL storage/distribution tank. MOL will be pumped to the solution regeneration tanks through a MOL loop.

Pebble lime will also be added to the oxidized material from another lime silo to the first of the overland conveyors that take the material from the oxidation pad to the leach pad.

Table 17-4: Main Process Reagents

Reagent	Area or Point of Addition	Dosage	Dosage unit
Sodium cyanide	Leach, Barren Solution Pond & MC	0.5	kg/t
Lime	Oxidation	1.22	kg/kg S to be oxidized
	Leach, Overland Conveyor to HLP	0.5	kg/tonne
Na ₂ CO ₃	Oxidation	0.6	kg/tonne solution
Zn dust	Merrill-Crowe	25.8	kg/kOz Au
		47.1	kg/kOz Ag
Lead Nitrate	Merrill-Crowe	15	ppm in PLS
Diatomaceous Earth (DE)	Merrill-Crowe	45.4	kg/filter batch
Melting Flux	Refining	5.5	g/oz of metal
Flocculant	Oxidation Solution Regeneration	20	g/tonne precipitate
Antiscalant	Barren Solution, Pregnant Solution	6	kg/tonne of solution

17.5 CONTROL SYSTEMS

A crusher control room in the primary crusher area will be the operating and control center for the crushing plant, particularly for the primary crusher.

A central control room (CCR) will be inside the Merrill-Crowe Plant building. From the CCR control consoles, crushing, screening, material handling systems, reagents, pumping systems, aeration system, Merrill-Crowe plant, and utility systems will be monitored or controlled.

A computer room adjacent to the CCR will contain engineering workstations (EWS), a supervisory computer, historical trend system, management information systems (MIS) server, programming terminal, network and communications equipment, and documentation printers. This is primarily used for distributed control system (DCS) development and support activities by plant and control systems engineers.

Although the facilities are normally controlled from the CCRs, local video display terminals are selectively provided on the plant floor for occasional monitoring and control of certain process areas. Any local control panels that are supplied by equipment vendors will be interfaced with the DCS for remote monitoring or control.

17.6 ASSAY AND METALLURGICAL LABORATORIES

A laboratory building has been provided for in the capital cost estimate. Provision has been made for facilities that include sample receiving, sample drying, sample preparation, metallurgical laboratory, wet laboratory, and fire assay for mine and process plant samples.

17.7 WATER CONSUMPTION

The Metates process plant is projected to require 74 m³/h of raw water makeup to sustain the operation. In addition, an estimated 20 m³/h of raw water for mine dust control and 1.25 m³/h for potable water are allocated, for a total consumption of 95 m³/h. A more extensive discussion of the site wide water balance is presented in Section 18.

17.8 POWER CONSUMPTION

The total connected power load is 11,691 kW, of which 7,742 kW is drawn in a typical year. This translates to about 11 kWh/tonne of material processed or \$1.11/tonne in power cost. Details of the power consumption are discussed in Section 18.

18 PROJECT INFRASTRUCTURE

18.1 SITE LAYOUTS

The general arrangement and basic operational components for the Metates site including the open pit, oxidation heap, heap leach pad, process facilities and waste dumps are shown on Figure 18-1. The various process facilities have been described in Section 17, while the various engineered structures are described in this section.

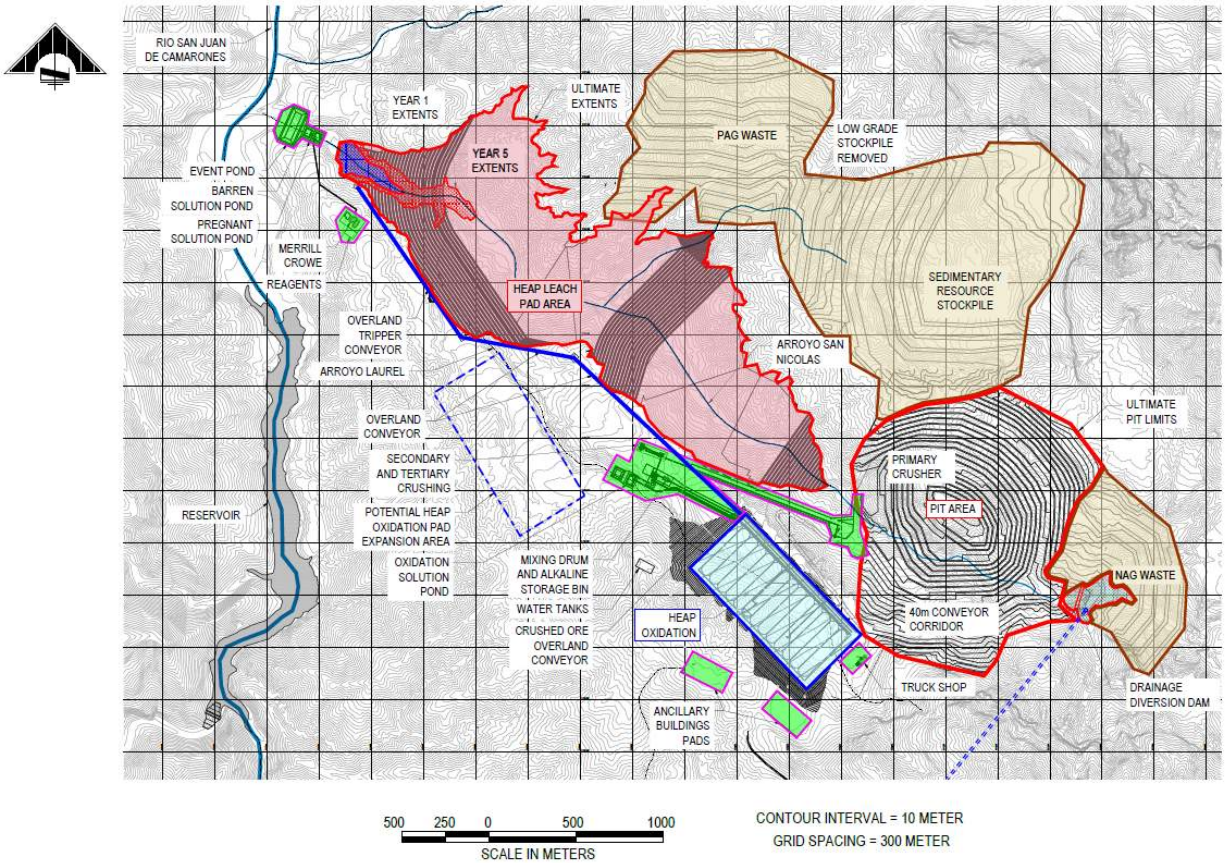

Figure 18-1: General Arrangement of Open Pit, Stockpile and Waste Rock Dumps and Process Facilities

18.2 ACCESS ROADS

Existing road access to the Metates sites is from Durango State. From the city of Durango, access is via Federal Highway 23 about 170 km to the town of Santiago Papasquiari and then west on Federal Highway 36 for about 144 km to the village of Ojito de Camellones. From Ojito de Camellones, access to the Metates site is then via about 50 km of unpaved dirt roads of variable quality (total road distance of about 364 km). See Figure 18-2. This same road allows access via a spur road to the village of San Juan de Camarones while the main road extends to other villages in the area including Vascogil and San Miguel el Alto. Travel time from Metates to Santiago Papasquiari, the closest location for goods and supplies, is about 5 hours with an additional 2 hours to reach Durango City.

This road access will be used for hauling in heavy equipment to the Metates site including haul trucks and shovels, crushing equipment, etc. As such, the existing bridges and overpasses will need to be evaluated to see if they can handle the weight of the various pieces of equipment and what might be required to allow passage. The unpaved part of the access road will need to be designed and reconstructed to accommodate this heavy equipment as well. Unpaved dirt roads will need to include a 0.5-meter shoulder for each lane and capped with an 8-inch layer of aggregate base course (ABC) (gravel) material. A ditch for drainage is provided in cut sections and a safety berm is provided for fill sections. The design speed is no more than 60 km/hour with a standard maximum grade of 10% with a few sections of steeper grades in switchback conditions. The normal minimum curve radius is 120 m with a 20-m minimum radius in switchback conditions. The drainage basins along the route of the unpaved portion of the access road will be surveyed and peak flows estimated to allow for appropriate sizing of culverts (round and trapezoidal section) and at grade ("vado") crossings.

Seasonal access to the Metates site from Sinaloa State is also possible during low water flows in the Rio San Lorenzo and tributaries (typically December to July). Paved road access from the cities of Mazatlán or Culiacán is possible to the town of Cosalá. A series of variably improved dirt roads extend northeast from Cosalá to a crossing on the Rio San Lorenzo where a primitive road then follows the river upstream to the Rio San Juan de Camarones where the road continues up to the Metates site. This access requires multiple river crossings but is a travel distance of only about 106 km from Cosalá to Metates. The road access between Cosalá and Metates might be locally improved to provide an alternate access route.

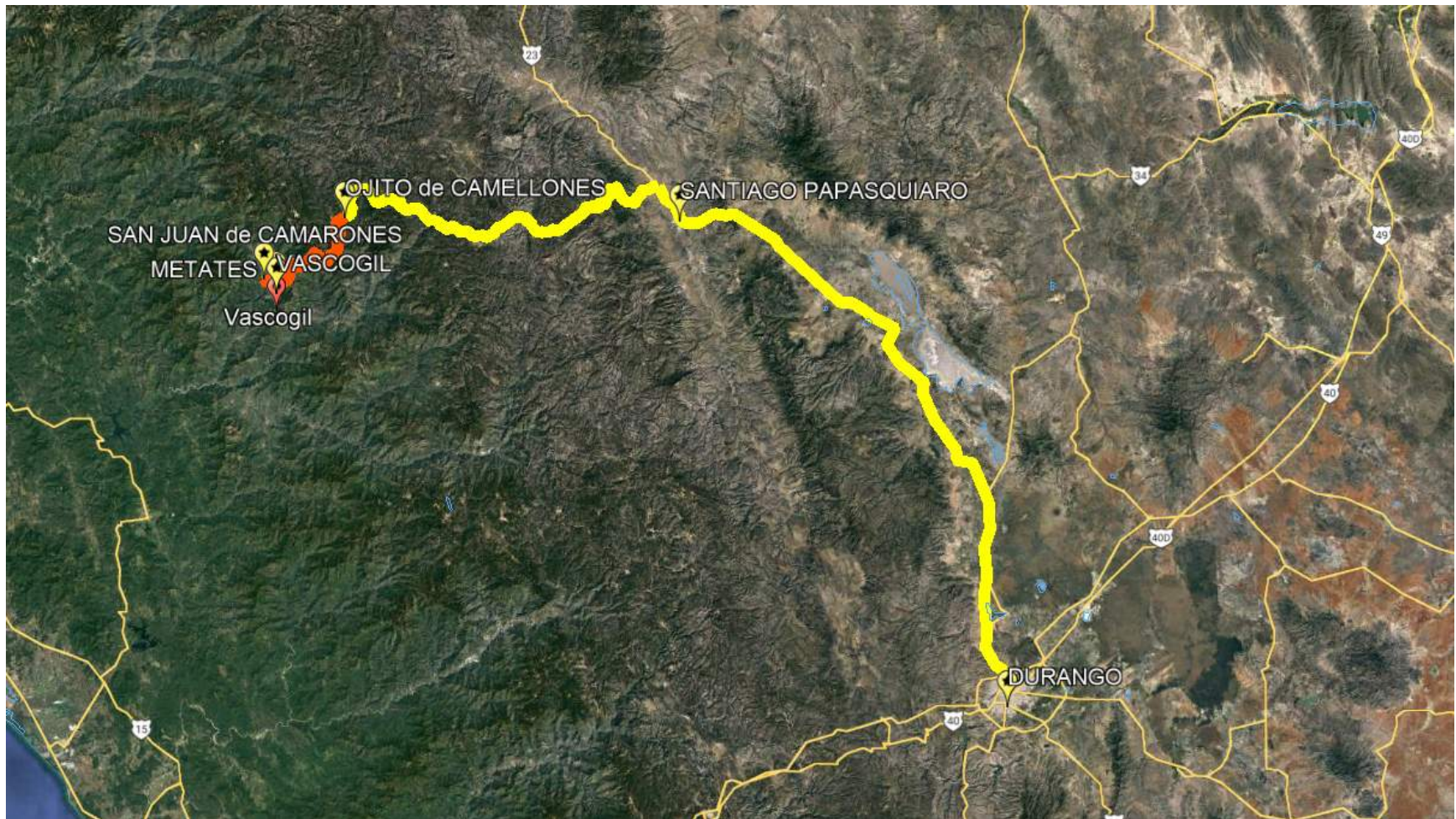

Figure 18-2: Access Roads

18.3 COMMUNICATIONS

There is currently no land line telephone service in the greater Metates area, but there is limited cellular phone coverage. There is also no established community wide broadband internet service available via cable. On an individualized basis, there are satellite-based services available that allow for both internet access as well as television. It would be anticipated that these satellite-based services would be improved to support the proposed mining activities. In addition, more robust cellular service would be implemented as well.

18.4 WATER RESOURCES AND SYSTEMS

18.4.1 Water Rights

Establishment of adequate fresh water sources to meet needs is a critical element in the development and success of the Metates Project. Schlumberger Water Services (SWS) was asked to conduct water rights and permitting investigations and to define strategies for water rights acquisition for the Metates Project for the previous study (SWS, 2012). SWS carried out a systematic investigation into the regulations and constraints related to the purchase of rights and their potential transfer. SRK Consulting issued an updated report describing the availability of surface water and water supply options for the project (SRK, 2015). The proposed strategies were based on an estimated annual peak surface water demand of approximately 20 Mm³/y or 55,000 m³/day, much larger than the 2,280 m³/day or 832,000 m³/y estimated for the currently proposed development plan. Appropriate surface and/or ground water rights must be developed and/or acquired as a condition of use.

Through a comprehensive research effort, important prevailing conditions for water right development were defined:

- CONAGUA is the only entity that regulates the operation of the Jose Lopez Portillo Dam (JLPD) and Comedero reservoir which is within the same drainage basin and downstream from the Metates Project. It was confirmed with CONAGUA that once the mine owns the proper water rights, they will allow the abstraction at the requested rate directly from the Comedero impoundment or elsewhere within the same drainage basin.
- Recently, CONAGUA updated the official water balance for the San Lorenzo Basin and indicated there was an average positive availability of 50 Mm³/y. In 2013, the update to the water balance reversed a long-standing ban on the allocation of new surface water rights within the San Lorenzo Basin.
- While there is currently surface water available, an application must be made to CONAGUA for those water rights. One of the conditions of granting a water right is immediate beneficial use for the full amount of the application. In the case of the Metates Project, demonstration of immediate use is not really possible.
- According to law, it is possible to acquire existing water rights by purchasing them from an allocated concession within the same basin and transferring those rights to a new location within the same basin.
- Official groundwater availability is set close to 50 Mm³/year. New groundwater rights can be acquired outside the irrigation district area so long as they do not affect existing users.
- The JLPD is operated to supply irrigation water preferentially over electrical generation. The irrigation district is the only candidate to sell water rights. Other users do not have enough volume and by law, concessions for municipal use are not candidates to be transferred.
- There is no precise information available to determine the exact price for the transfer of allocated water rights by volume. Based on discussions with CONAGUA representatives, it is estimated that the one-time cost per cubic meter is probably within the range of US\$0.50 to US\$1.00/m³. This cannot be confirmed until negotiations with ejidos and private owners of the water rights get started. A cost of US\$1.00/m³ was assumed in this study.

- A mechanism to detect available water rights to be transferred is to register the water demand at the Culiacán CONAGUA Water Bank System. To investigate actual market costs, it is suggested by CONAGUA to publish a specific demand without creating expectation among irrigation district groups.
- By law, any water right transfer application should be resolved within a 2-month time period. However, it can take longer if additional information is requested by the authority.
- It is impossible to know the amount of time needed to conclude negotiations to purchase surface water rights. The requested time to complete the permitting on surface water or groundwater extraction and water rights transfer varies depending on the ease of negotiations with landowners and water rights users. If all the submitted information is suitable for CONAGUA and no risks of adverse effects are identified, the process can take from a couple of months to a year.

The following strategies to develop water rights for a specific source were identified.

18.4.2 Surface Water Rights

- Surface water use is priced by CONAGUA according to different zones around Mexico as well as relative availability within that zone. The fees for water use applicable to the San Lorenzo basin are published in the Diario Oficial de la Federación on an annual basis. The rate is the same regardless of user, be it industrial or agricultural. The fee assumed for this study is US\$1.00/m³.
- The irrigation district is generally located south of the city of Culiacán, and extends some 20 to 25 km inland from the coast. It is the only reliable source for surface water rights. In the irrigation district, there is an estimated total of approximately 825 Mm³/year of water rights.
- Of the total water rights established and registered within the irrigation district, about 16% are held by private owners with the balance held by various ejidos.

18.4.3 Groundwater Exploitation and Development of Water Rights

- Groundwater use is governed by the same fee structure as established by CONAGUA for surface water use within that zone.
- Groundwater use has an advantage over surface water use in that new concessions can be granted outside the irrigation district area.
- The potential use of groundwater resulting from dewatering of the open pit at Metates is possible as Mining Law (Article 19) sets that any mine has the right to use waters captured within the mines. Specific information about yields, engineering designs and several environmental permits are required to complete CONAGUA applications. A site-wide water balance assumes that groundwater related to pit dewatering is used at the Metates site for process water and makeup.
- A Ranney well, river infiltration gallery, or a well field may provide suitable volume. The best location would be in an area of thick gravel-sand deposits in hydraulic communication with the river itself.

18.4.4 Project-Wide Water Balance

18.4.4.1 Modeling

Project water balance modeling efforts for an alternate processing plan were developed by SRK Consulting in conjunction with Schlumberger Water Services (SWS) in 2016. The results of the effort were used to inform the current processing plan.

The model used historical climate values compiled from long-term weather stations in the vicinity of the project site resulting in a 46-year precipitation and evaporation record. The climate model used this 46-year record to create climate scenarios that included average conditions and extended wet and dry periods.

18.4.4.2 Water Supply and Conveyance

Water supply and conveyance at the Metates Project is a combination of surface and groundwater abstraction from different sources, at distant locations. Water must be stored during periods of surplus to be used during times of deficit and geography dictates the locations of these storage facilities without regard to project convenience.

The sources of water are differentiated as follows:

- Contact runoff describes runoff generated by the project facilities. This water is captured by the project and will be used by the process.
- Precipitation captured by the facilities describes precipitation that does not generate runoff but is nonetheless captured and brought into the system. This inflow includes precipitation captured by open water surfaces that do not release flow (i.e., heap leach pads, oxidation pads and ponds) as well as precipitation that infiltrates into the facilities and will be ultimately captured or used by the Project.
- Groundwater inflows include all groundwater intercepted during the project operations. This includes pit wall seepage to the pit sumps, pit wall depressurization through horizontal drains or active well dewatering, and moisture in the mineralized material mined from the pit. Groundwater wells are anticipated to be developed and utilized; initial capital has been allotted for the development of this infrastructure.

18.4.5 Mine Pit Diversion Dam and Tunnel

The mine pit diversion dam will be constructed in the Arroyo San Nicholas upstream of the mine pit as shown on Figure 18-1. The mine pit diversion dam will intercept surface flow from the watershed upstream of the mine pit. A 5-m diameter and 2.7-km long diversion tunnel will be constructed to convey the intercepted and impounded stream drainage water to an outlet point in the Arroyo Camarones which will eventually report to the main Rio San Juan de Camarones water storage reservoir (Brierley Associates, 2012a). The diversion dam is sized to contain the average year, 24-hour peak storm runoff.

18.4.6 Rio San Juan de Camarones Water Storage Dam and Reservoir

As shown on Figure 18-1 and Figure 18-3, a main fresh water supply reservoir will be constructed by Year -1 in the southwest section of the project area within the main Rio San Juan de Camarones drainage just downstream of the confluence with the Arroyo Camarones. The reservoir will impound water from the Rio San Juan as well as water collected by the mine pit diversion dam and diverted to the Arroyo Camarones via the diversion tunnel. The dam will be constructed with rollercrete fill with an 8% cement additive and a reinforced concrete shell of 0.75-m thickness. The total height of the dam will be approximately 32 m from the downstream toe elevation 540 m to the crest elevation

572.0 m. The downstream and upstream slopes are 2.5H:1V and 2H:1V, respectively. A cut-off trench will be excavated under the upstream toe to allow for the alluvium to be removed (Ausenco, 2015d).

The dam creates a reservoir to provide storage for 4.0 Mm³ of water by Year -1 including 0.5 Mm³ of dead load storage for sediment build up. To maintain a 3.5 Mm³ storage capacity year-round, yearly maintenance removal of stream sediments will be required as needed during dry season.

The reservoir level and the water available will fluctuate, dropping down in dry seasons and increasing in wet seasons with anticipated non-contact water spillway overflows through most of the wet season months. Water in the reservoir will be pumped to the plant area for use in operations, primarily as fresh water supply. An upstream coffer dam would be difficult to construct and maintain in the dam location, which is close to the confluence of the Arroyo Camarones side stream. Therefore, the dam will be built in two stages with the initial stage being a coffer dam at elevation 550 m (5 m above valley floor) with a 5-m wide crest that will become a bench on the upstream slope of the dam. The second stage will be constructed downstream of the coffer dam to elevation 572 m leaving the coffer dam crest intact. The initial stage allows for the lining and controlling of the valley stream flows during the remainder of the rollercrete dam and crest overflow concrete lined spillway construction.

Borrow materials for the dam construction will be obtained from within the reservoir impoundment. The impoundment borrow location will be close to the dam and enhance the reservoir storage efficiency.

METATES SULPHIDE HEAP LEACH PROJECT - PHASE 1 FORM 43-101F1 TECHNICAL REPORT

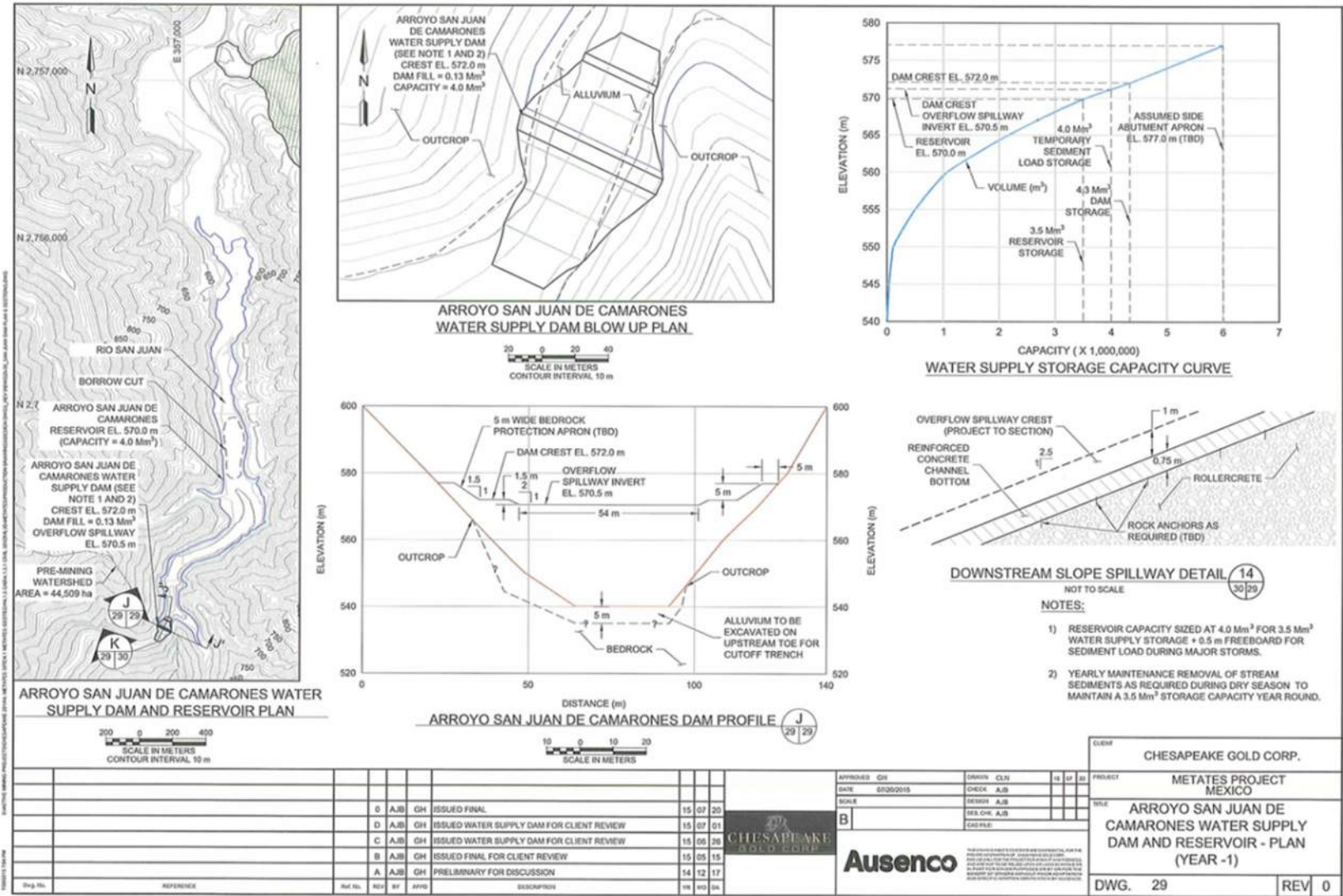

Figure 18-3: San Juan de Camarones Dam and Reservoir Plan and Sections

18.5 POWER SUPPLY

Electrical power for the Metates mine will be transmitted along a newly constructed 115 kV power line that will tie into the existing CFE grid at a substation to be constructed near the Ciénega II substation. The 115 kV line will extend approximately 20 km to the southwest to the Metates site and once complete the line will be turned over to the CFE. Completion of the power supply infrastructure will also require a switching substation with three high voltage feeders at the existing power line, and a substation at the Metates site. A depiction of the projected run of the power lines can be found in Figure 18-4.

Specification of major equipment was used to develop power demand for each area of the process facility. M3 was responsible for the development of the major equipment list, and subsequently the estimation of power demand by supporting equipment. The operating loads by plant area are described in Table 18-1.

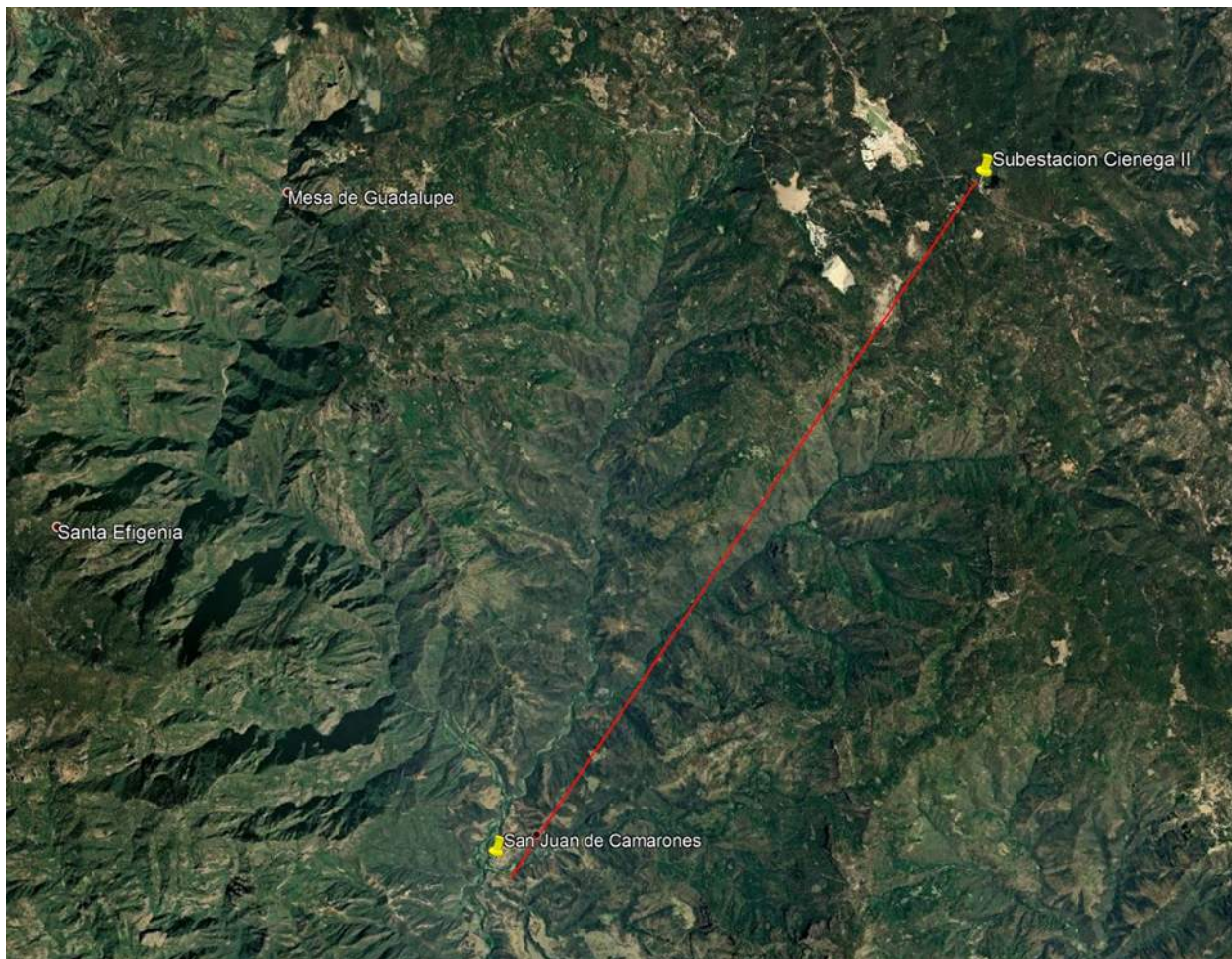

Figure 18-4: Metates Proposed Power Line Alignment

Table 18-1: Operating Loads

Plant Area	Total hp	Total kW
Area 100 – Primary Crushing	1,050	783
Area 200 – Fine Crushing	2,325	1,734
Area 250 – Mixing and Conveying	1,680	1,253
Area 300 – Oxidation Pad and Ponds	4,570	3,408
Area 350 – Soda Ash Regeneration and Make up	286	213
Area 400 – Leach Pad and Ponds	3,510	2,617
Area 500 – Merrill Crowe	955	712
Area 550 – Refinery	865	645
Area 600 – Water Systems	150	112
Area 650 – Fresh Water Systems	50	37
Area 800 – Reagents	187	140
Area 900 – Ancillaries and Buildings	50	37
Total	15,678	11,691

18.6 GEOCHEMICAL STUDIES OF MINE WASTE ROCK

18.6.1 Waste Rock Static Geochemical Tests Results

A statistical summary of all available acid-base accounting (ABA) geochemical test data is presented in Table 18-2 and includes historical data.

As available, standard ABA static test data included:

- Paste pH and paste electrical conductivity (EC);
- Total sulphur and sulphur speciation data;
- Acid-base accounting (ABA), including determination of acid-generation potential (AP) and neutralization potential (NP);
- Net acid generation (NAG) testing and NAG pH.

Various ABA guidance criteria are published and used for initial characterization and decision-making. The most common, standard criteria include net neutralization potential (NNP) (calculated as the difference between NP and AP), and the neutralizing potential ratio (NPR) (calculated as the NP/AP ratio). USEPA Region 10 (1999) summarizes some of the interpretative methods as follows:

- NNP values greater than 20 t CaCO₃/Kt suggest potentially acid-neutralizing material or non-acid generating (NAG),
- NNP values between -20 and 20 t CaCO₃/Kt suggest an uncertain potential,
- NNP values less than -20 t CaCO₃/Kt suggest that the material is PAG,
- NPR values greater than 3:1 suggest NAG material,
- NPR values less than 3:1, but greater than 1:1, suggest uncertain potential, and
- NPR values less than 1:1 suggest materials are PAG.

Also, Mexican regulation NOM-141-SEMARNAT-2003 indicates that samples with an NPR of less than 1.2 are considered PAG. For this characterization, the 1.2:1 and the 3:1 NPR criteria have been used, as well as the +/- 20 t CaCO₃/Kt NNP criteria.

Table 18-2: Waste Rock Static ABA Geochemical Data Statistical Summary

Major Lithologic Unit	Statistical Calculation	Paste pH (su)	Paste EC (us/cm)	Sulfur Forms (%)				AP (t CaCO3/KT)	NP (t CaCO3/KT)	NNP (t CaCO3/KT)	NPR	NAG pH (su)
				Total	Pyritic	Sulfate	Org/Resid					
Tertiary Volcanics	COUNT	11	9	22	20	20	20	22	22	22	22	11
	MIN	7.5	113	0.01	0.01	0.01	0.01	0.2	1.5	0.9	1.2	4.8
	MAX	8.5	2350	2.81	2.20	0.31	0.54	69	121	106	224	10.3
	AVG	7.9	1289	0.51	0.39	0.07	0.11	11	38	27	30	5.8
	ST DEV	0.3	1067	0.80	0.59	0.08	0.18	18	33	28	53	1.6
	GEOMEAN	7.9	682	0.09	0.08	0.03	0.02	2.2	21	15	9.8	5.6
Tertiary Basal Conglomerate	COUNT	3	3	3	3	3	3	3	3	3	3	3
	MIN	6.1	132	0.02	0.01	<0.01	<0.01	0.3	1.0	0.1	1.1	4.6
	MAX	8.2	424	0.08	0.05	0.01	0.02	1.6	3.4	2.2	3.2	5.2
	AVG	7.1	325	0.05	0.03	0.01	0.01	1.0	2.0	1.0	2.3	4.9
	ST DEV	1.1	167	0.03	0.02	0.003	0.01	0.7	1.2	1.0	1.1	0.3
	GEOMEAN	7.1	286	0.04	0.03	0.01	0.01	0.8	1.8	0.6	2.1	4.9
Sedimentary	COUNT	44	38	71	65	65	65	71	71	71	71	44
	MIN	2.9	549	0.21	0.11	0.02	<0.01	3.4	0.5	-381	0.001	1.9
	MAX	8.1	2940	13.80	12.20	0.80	2.57	381	43	23	2.8	5.8
	AVG	5.3	1463	3.68	3.13	0.10	0.52	98	12	-86	0.4	2.5
	ST DEV	1.3	674	2.70	2.59	0.11	0.49	79	12	85	0.6	0.9
	GEOMEAN	5.1	1327	2.73	2.18	0.07	0.26	69	6.4	nc	0.1	2.4
Intrusive	COUNT	8	7	14	13	13	13	14	14	14	14	8
	MIN	2.8	794	0.61	0.49	0.01	0.06	15	0.5	-311	0.002	1.8
	MAX	7.1	7710	10.80	10.13	0.45	3.08	317	61	46	4.0	5.6
	AVG	4.8	2383	4.67	4.06	0.10	0.68	123	15	-109	0.5	2.5
	ST DEV	1.4	2452	2.86	2.97	0.12	0.74	90	18	103	1.1	1.3
	GEOMEAN	4.6	1727	3.78	2.96	0.06	0.49	91	5.3	nc	0.1	2.3

na - not available/analyzed

nc - not calculated

< indicates parameter not detected at the method detection limit (MDL). Value shown is the MDL.

Figure 18-5 shows all the samples shown on Table 18-2 classified against NP and AP as well as the NPR ratio.

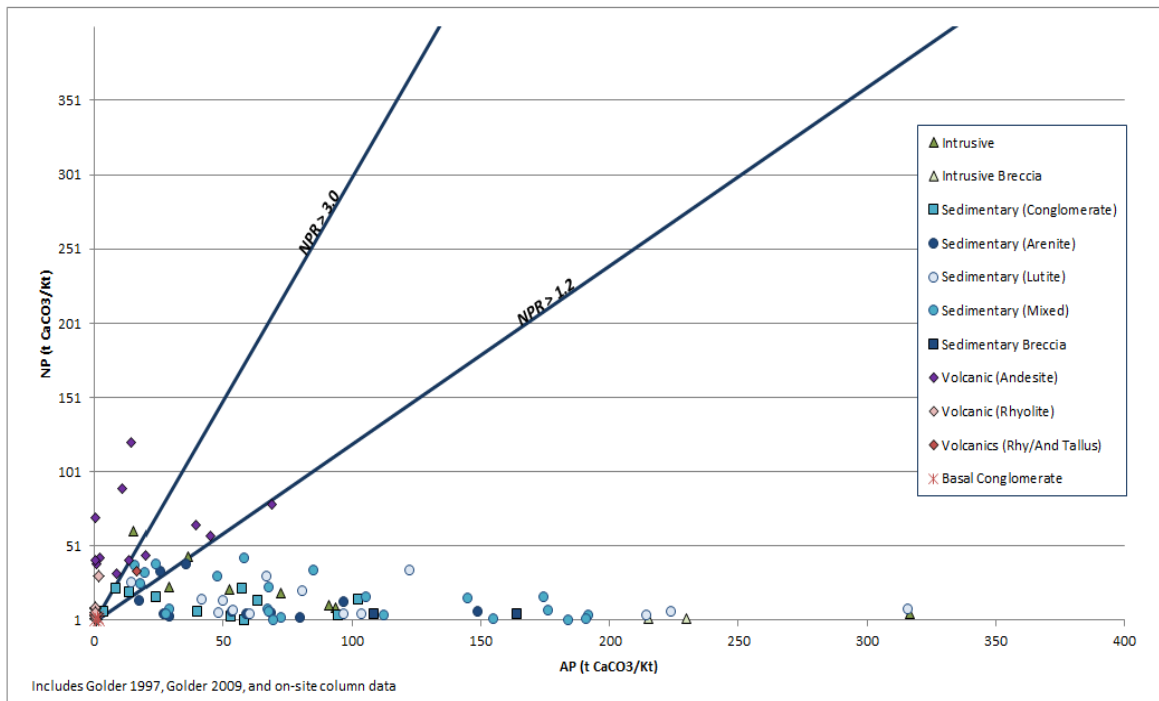

Figure 18-5: Waste Rock Static Geochemical Data, ABA Data with NPR Criteria

18.6.2 Waste Rock Kinetic Geochemical Test Results

Humidity cells are designed to simulate the response of minerals to repeated wetting and drying cycles and create optimal conditions for chemical weathering in the environment. They provide information on oxidation rates, acid generation over time, metal leaching rates, and the development of acidic conditions on the surfaces of rock material. The 1997 geochemical testing program included kinetic testing of 18 waste rock samples in HCTs over a period of 16 weeks. Details and results of that testing program are provided in Golder (1997).

InterraLogic (2013) proposed the construction and long-term operation of a series of columns to generate site specific information on the various waste rock types and how these results might compare with shorter term HCT tests on identical sample splits. Details of the proposed column materials, column design/construction, and proposed sampling analysis protocols are outlined in InterraLogic (2013). Column materials were selected to represent the variety of waste rock materials as well as a range of sulphur content within the sedimentary materials. Within the predominant sedimentary waste rocks, test results suggest a strong correlation between sulphur content and ABA characteristics. The column samples tried to better define this correlation with sulphur by selecting samples with specific limits of sulphur content. The larger scale of the column tests, the coarser size of the particles (about 50% + 20mm), the on-site location and environmental conditions and the general longer-term operation support the column test results as being more reliable and representative for extrapolation of future conditions than shorter term HCT results. Table 18-3 presents the material composition and construction details for each of the nine waste rock columns.

Table 18-3: On-Site Column Construction Summary

On-site Column Identification	Lithologic Material	Source of material	# Sample Intervals	Total weight (kg)	Approximate material thickness (m)
Sed <1% S	Sedimentary	crushed core - composite	57	288	0.57
Sed 1-2% S	Sedimentary	crushed core - composite	85	390	0.57
Sed 2-3% S	Sedimentary	crushed core - composite	59	283	0.57
Sed 3-4% S	Sedimentary	crushed core - composite	76	254	0.57
Sed 4-5% S	Sedimentary	crushed core - composite	69	239	0.57
Sed >5% S	Sedimentary	crushed core - composite	60	215	0.57
Intrusive	Intrusive	crushed core - composite	38	107	0.57
Andesite	Volcanic (Andesite)	surface road cut outcrop	bulk sample	200	0.57
Rhyolite	Volcanic (Rhyolite)	surface road cut outcrop	bulk sample	177	0.57

**Sample intervals and sample borehole locations are presented in Appendix A.*

Sample splits from each of the nine on-site columns were also submitted for the standard HCT procedure in 2014, referred to as 2014 HCT samples. Three of those cells (andesite, rhyolite and sed <1% S) were terminated after 40 weeks, and the remaining six cells were terminated after 60 weeks of testing when it was determined that cell conditions and the rates of metals leaching had stabilized. ABA characteristics of the selected HCTs are presented graphically in Figure 18-6, and demonstrate the range of materials tested.

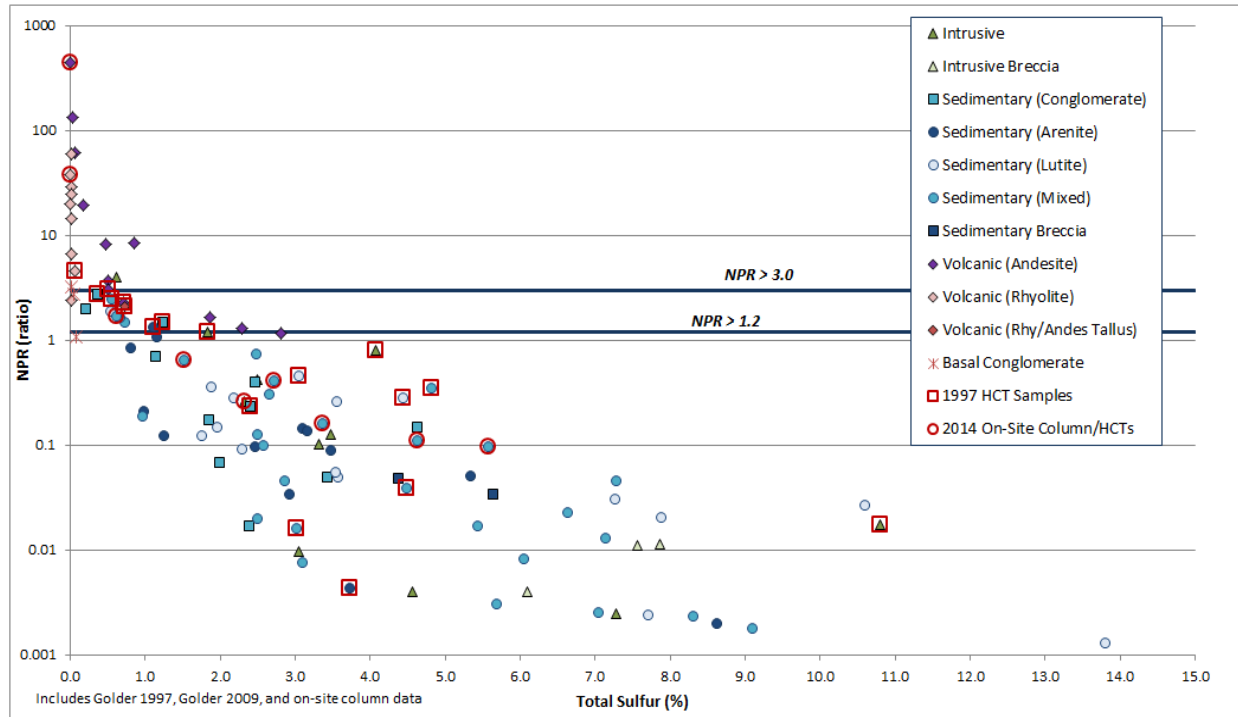

Figure 18-6: Total Sulphur and NPR for 1997 HCT and 2014 HCT Samples

Overall, the 2014 HCT's tended to be slightly less reactive than the 1997 samples of similar type. Put another way, the 2014 HCT's were consistent with the lower sulphur sample equivalent of the 1997 HCT's. For example, the 1-2% and 2-3% sulphur tests from 2014 resulted in pH values of at least 1 pH unit higher than their 1997 counterparts. Otherwise, HCT results from the two events were mostly consistent.

Summary results of the nine samples comprising the 2014 HCT samples are shown in Table 18-4. These results confirm the two volcanic rock types generate near neutral pH, with low alkalinity but also low acidity and sulfate levels. The sedimentary samples with the lower sulphur levels (<1% and 1-2% S) had similar overall results to the volcanic samples. The intrusive sample and the remaining sedimentary samples demonstrated generally lower pH values and alkalinity values and higher acidity and sulfate values in relation to higher contained sulphur levels.

Table 18-4: Summary Results of 2014 HCT Samples

HCT (On-Site Column Sample Splits)	Formation	Final Results through Week	Waste Rock HCT - Weekly Results							Waste Rock HCTs - Water quality standards comparison			
			Final pH (su)	Alkalinity (mg/L as CaCO3)		Acidity (mg/L as CaCO3)		Sulfate (mg/L)		Comparison to USEPA MCLs			Comparison to NOM
				First Flush (week 0)	Final	First Flush (week 0)	Final	First Flush (week 0)	Final	pH < 6.5 su	> Primary MCL	> Secondary MCL	exceedances
SED <1% S	Sedimentary	40	7.7	18	63	6	<1	770	40	no	Sb	Mn, Fe, SO4	none
SED 1-2% S	Sedimentary	60	7.3	18	23	18	<1	700	88	no	As	Mn, Fe, SO4	none
SED 2-3% S	Sedimentary	60	6.2	<1	5	465	10	1,600	303	yes	Sb, As, Be, Cd, Pb	Al, Fe, Mn, SO4	none
SED 3-4% S	Sedimentary	60	4.8	1	1	1101	18	589	297	yes	Sb, As, Be, Cd, Pb	Al, Cu, Fe, Mn, SO4	none
SED 4-5% S	Sedimentary	60	2.8	<1	<1	520	340	2,000	1,042	yes	Sb, As, Be, Cd, Pb	Al, Cu, Fe, Mn, SO4	none
SED >5% S	Sedimentary	60	3.0	<1	<1	1111	125	800	620	yes	Sb, As, Be, Cd, Cu, Pb, Tl	Al, Fe, Mn, SO4	none
INTRUSIVE	Intrusive	60	6.6	6	7	352	8	600	97	yes	As, Be, Cd, Pb	Al, Fe, Mn, SO4, Zn	none
ANDESITE	Volcanic (Andesite)	40	7.3	44	22	<1	<1	30	<1	no	none	none	none
RHYOLITE	Volcanic (Rhyolite)	40	6.7	31	5	8	1	10	<1	no	none	Al	none

NOTES:

USEPA MCL: Based on USEPA Maximum Contaminant Limits, primary and secondary drinking water standards.

NOM: Mexican government maximum allowable standards (NORMA Oficial Mexicana, NOM-1276-SSA1-1994)

Concentrations above the MCLs or NOM standards in at least one composite leachate sample are highlighted yellow

The on-site columns were set up in June 2014 with the first sample episode taking place that same month and the last episode included here as of June 2015 for a total of 6 sampling episodes. A summary of the leachate sampling for the on-site columns is presented in Table 18-5 and Figure 18-7.

METATES SULPHIDE HEAP LEACH PROJECT - PHASE 1
FORM 43-101F1 TECHNICAL REPORT

Table 18-5: On-Site Column Leachate Water Quality Summary

On-Site Column	Formation	Total Sulfur (%)	NAG pH (su)	Results through Date	Leachate water quality						Leachate water quality		
					Water quality standards comparison						Water quality standards comparison		
					pH (su)		Alkalinity (mg/L as CaCO ₃)		Sulfate (mg/L)		Comparison to USEPA MCLs		Comparison to NOM
					Initial Sample	Final	Initial Sample	Final	Initial Sample	Final	> Primary MCL	> Secondary MCL	exceedances
SED <1% S	Sedimentary	0.62	5.5	June 2015	6.2	6.9	6.3	10	nd	155	none	pH, Mg, Mn	none
SED 1-2% S	Sedimentary	1.52	2.8	June 2015	4.1	3.0	<1	<1	nd	15,078	Cd	pH, Al, Fe, Mg, Mn, SO ₄ , Zn	none
SED 2-3% S	Sedimentary	2.72	2.6	June 2015	2.9	2.2	<1	<1	nd	19,795	As, Be, Cd, Cu	pH, Al, Fe, Mg, Mn, SO ₄ , Zn	none
SED 3-4% S	Sedimentary	3.37	2.5	June 2015	2.8	2.1	<1	<1	nd	49,788	As, Be, Cd, Cu	pH, Al, Fe, Mg, Mn, SO ₄ , Zn	none
SED 4-5% S	Sedimentary	4.63	2.4	June 2015	2.6	2.1	<1	<1	nd	32,143	As, Be, Cd, Cu, Pb	pH, Al, Fe, Mg, Mn, SO ₄ , Zn	arsenic
SED >5% S	Sedimentary	5.58	2.4	June 2015	2.5	2.0	<1	<1	nd	29,363	Sb, As, Be, Cd, Cu	pH, Al, Fe, Mg, Mn, SO ₄ , Zn	arsenic
INTRUSIVE	Intrusive	2.32	2.7	June 2015	6.2	2.6	<1	<1	nd	1,960	As, Cd, Pb	pH, Al, Fe, Mg, Mn, SO ₄ , Zn	none
ANDESITE	Volcanic (Andesite)	<0.01	10.3	June 2015	7.3	7.1	36	28	nd	127	none	pH, Mn	none
RHYOLITE	Volcanic (Rhyolite)	<0.01	5.3	June 2015	7.1	3.4	5.2	1.9	nd	151	none	pH, Al, Mn	none

NOTES:

nd - value not determined.

< Indicates value not detected at the method detection limit (MDL). Value shown is the MDL.

USEPA MCL: Based on USEPA Maximum Contaminant Limits, primary and secondary drinking water standards.

NOM: Mexican government maximum allowable standards (NORMA Oficial Mexicana, NOM-1276-SSA1-1994)

Concentrations above the MCL standards in at least one leachate sample are highlighted yellow.

Concentrations above the NOM standards in at least one leachate sample are highlighted orange.

METATES SULPHIDE HEAP LEACH PROJECT - PHASE 1 FORM 43-101F1 TECHNICAL REPORT

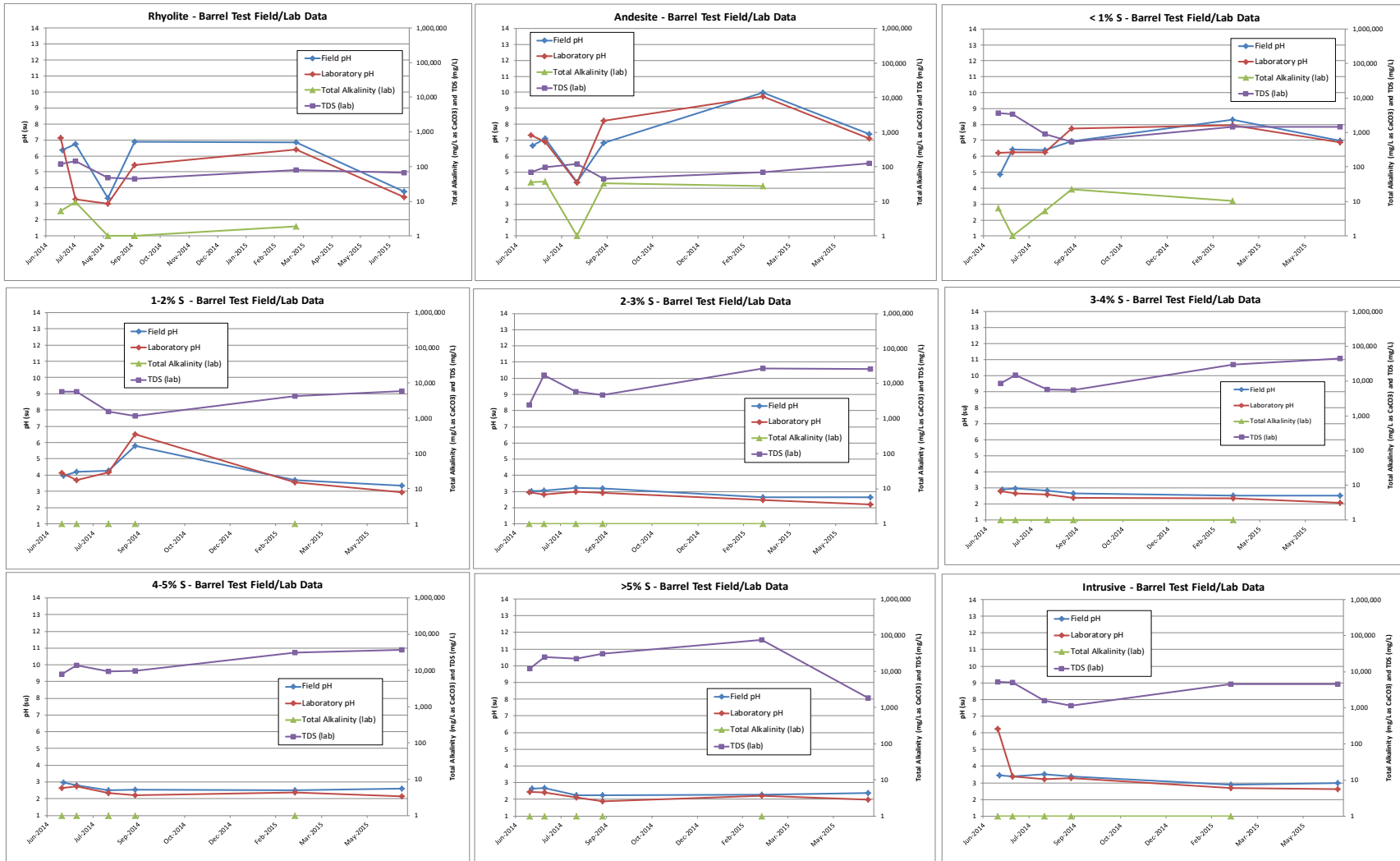

Figure 18-7: On-Site Column Data-Field and Lab pH, Total Alkalinity

18.6.3 Summary of Waste Rock Geochemical Testing

Static geochemical analyses from historical and recent testing programs included paste pH, sulphur speciation data, ABA analysis and NAG testing on 110 waste rock samples, including 71 samples of sedimentary rock units. Total sulphur concentrations in the sediments ranged from 0.21% to 13.8%, with an average concentration of 3.7%. The NP of the sedimentary rock was generally low to moderate, and all but three samples had NAG pH values below 4.5 indicating acid-generating behavior under aggressive oxidation. Based on the NNP criteria, all the sedimentary samples are considered either uncertain (20%) or PAG (80%) and fell below the USEPA NPR criterion (< 3.0) indicating PAG material, and 87% of these samples were below the NOM criterion (< 1.2) indicating PAG material. The intrusive samples (14) contained mostly moderate to high sulphur concentrations, averaging 4.7%, and gave similar overall results as the sedimentary samples.

The 22 volcanic samples contained low to moderate total sulphur content, averaging 0.50%. Average NP in the volcanics was also low to moderate, with NP in the andesite in the form of calcite. The NAG pH results for most volcanic samples were approximately 5-6 indicating the samples are not likely to generate significant acidity. The average NNP and NPR values for the volcanic samples also indicate non-acid generating behavior.

Kinetic geochemical testing has included historic HCT's as well as new paired tests of HCTs and on-site columns testing rhyolite (volcanics), andesite (volcanics), intrusive, and sedimentary samples (<1% S, 1-2% S, 2-3% S, 3-4% S, 4-5% S, and >5% S). The columns were operational by June 2014 and water samples were collected on six sampling events between June 2014 and June 2015. The paired HCTs operated for 40 to 60 weeks. The volcanics and <1% S sedimentary column leachate samples maintained (in general) circum-neutral pH conditions, measurable alkalinity, and low sulfate concentrations during the testing period; this behavior is consistent with the static geochemical data and HCT testing. The field columns containing the higher sulphur content sedimentary and intrusive samples became acidic with high sulfate and metals concentrations almost immediately. The leachate samples from these columns reflect the static test data and NAG pH results. However, these results are in contrast with the results of the HCTs where acid conditions have developed more slowly or not at all during testing. The low acid production in the HCTs indicates that the sulphide material in the cells was not aggressively oxidizing which may be attributable to drying conditions (i.e., low moisture content) in the cells. The column results are consistent with the HCT results in terms of identifying constituents of concern; however, the concentrations were significantly higher in the column leachate samples.

18.6.4 Summary of Waste Rock Material Geochemistry Characteristics

- Pyrite (sulphide sulphur) was present in all samples except some of the rhyolites.
- Lutite-arenite and conglomerate (all sediments) and intrusive samples were generally all considered to be PAG, except where levels of contained sulphide sulphur were less than about 2%.
- Significant siderite was present in samples, indicating that neutralization potential (NP) values based on Sobek methods may underestimate the NP and that oxidizing methods (e.g., net acid generation (NAG) testing using hydrogen peroxide) are likely more representative of actual NP.
- Andesite is considered not potentially acid generation (non-PAG) with significant NP (as dolomite) and low to moderate sulphur content.
- Basal conglomerate and rhyolite samples are also considered non-PAG, with both low NP and low sulphur content.
- Metals leaching was highly variable across lithology types; however, it was fairly well (inversely) correlated with effluent/rinse pH.

18.6.5 Implications for Closure

In general, results indicate that the waste rock can be managed during operations and closed after mining by standard best practices for mine closure.

Table 18-6 presents a summary of the mineralized material and waste tonnages as defined for this PEA.

Table 18-6: Summary of Mineralized Material and Waste Rock Generation

Mined and Processed Materials	Tonnage (Kt)	Percent of Total Mined
Metates Site		
Mineralized Material (Direct Feed)	127,294	24%
Total Low-Grade Stockpile	38,797	7%
Waste Rock (Incl. Seds)	367,907	69%
Total Mineralized Material + Waste Rock	533,998	100%

18.6.6 Pit Lake Model and Closure

Hatch (2016) prepared a pit lake model and closure plan for the Metates site. The model and plan were developed for a larger pit than is currently being considered in the process plan, but the results are still relevant to the smaller pit that is projected by this study's mining schedule. An update to the model should be developed when this study is advanced to the preliminary feasibility level.

The work that serves as a foundation for closure planning included the development of a pit lake model to predict the filling rate, ultimate water level, and water quality expected for the lake that will form in the pit and evaluates long term pit lake management options. The pit lake model utilized a GoldSim based water balance and simulation framework to predict pit lake levels. The model also incorporated a PHREEQC-based chemistry model to incorporate water chemistry inflows into the pit and geochemical interactions to predict pit lake chemistry and water quality through time. Figure 18-8 shows water balance components for the pit lake model.

As this process plan is developed to a preliminary feasibility level, the closure plan will be refined by repeating this modeling exercise. The results of the previous modeling effort indicate that this smaller scale closure plan will be simple and executable.

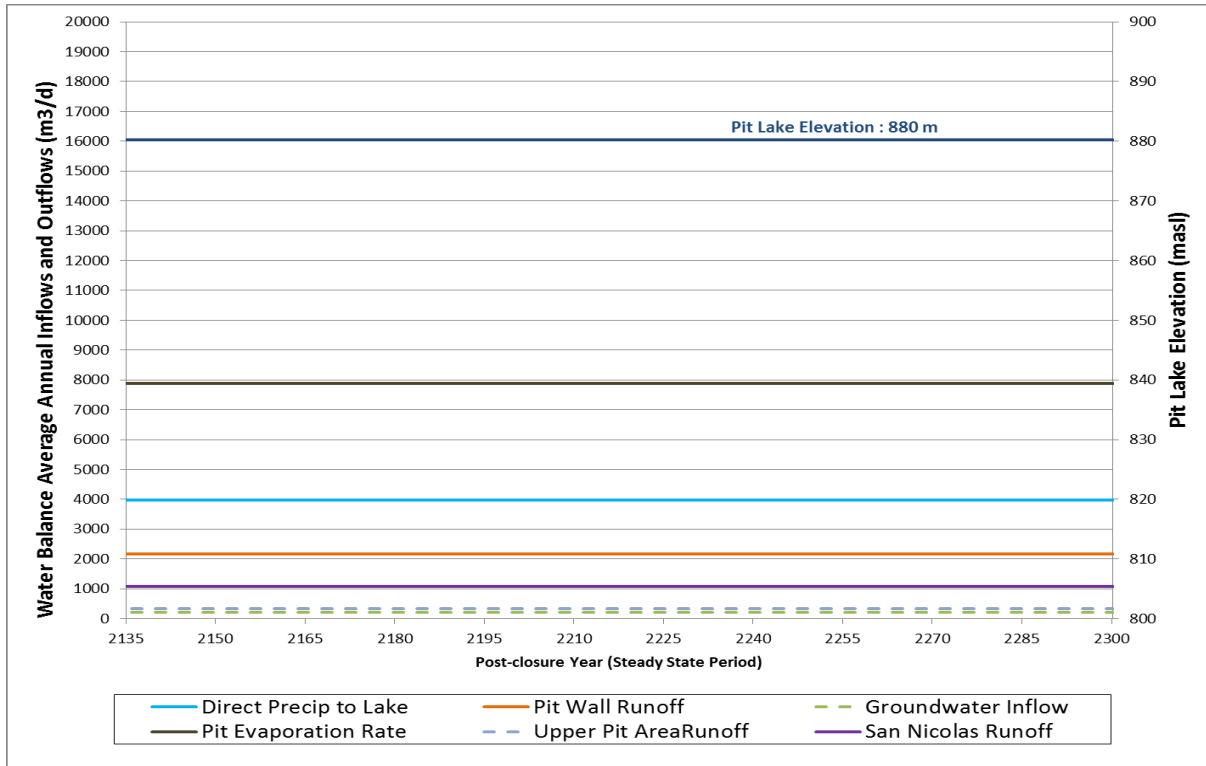

Figure 18-8: Water Balance Components of Long-Term Closure for the 880 meter Elevation Pit Lake

An example of the pH results of the predicted pit lake water chemistry for the four model alternatives is shown in Figure 18-9. Pit lake chemistry for the alternatives was also evaluated for total dissolved solids (TDS), trace metals, sulfate, and arsenic.

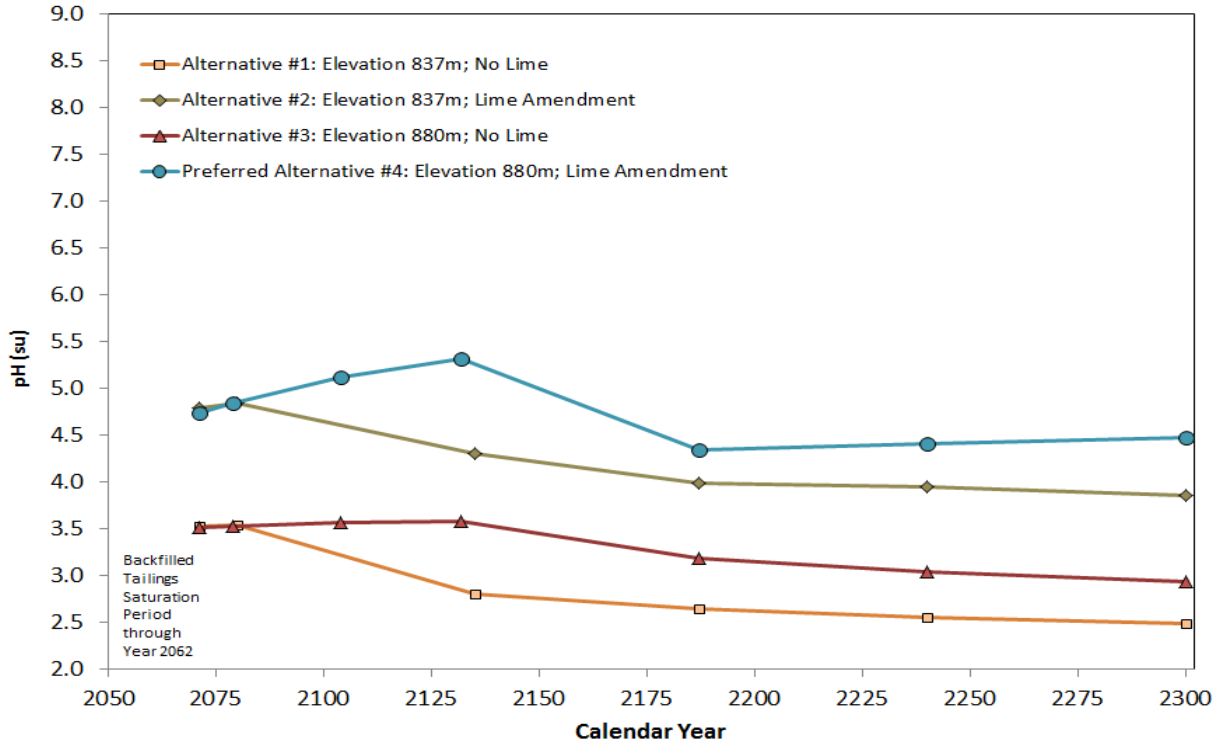

Figure 18-9: Pit Lake Water Quality Modeling Results –pH

18.7 RECLAMATION AND CLOSURE AT THE METATES SITE

As part of the 2013 PFS, InterraLogic (2013b) developed a focused program of geochemical characterization test work and related technical evaluations that supported a number of important components of the waste rock management, as well as closure and reclamation strategies. The body of technical assessments, testing and evaluation was critical to the integration of active ARD mitigation, concurrent reclamation and closure planning into the overall mining and processing operations with the major objective of improving both short and long-term environmental sustainability on the Metates Project. This section provides a technical overview of the plans developed for the Metates site, with emphasis on waste management operations.

Reclamation and closure are closely interrelated. Closure concepts identify what reclamation is required. Reclamation will be performed concurrent with other project activities to the maximum extent practical to reduce closure costs at the end of operations. Concurrent reclamation serves a number of purposes including:

1. Reducing the visual impact of project operations from surrounding areas;
2. Spreading out reclamation costs and financial assurance requirements associated with the project;
3. Providing an opportunity for adaptive reclamation techniques to ensure success; and
4. Improving the overall quality of the contact stormwater generated from the site.

The primary issues of concern relating to reclamation and closure of the Metates mine and process facilities include:

1. Physical aspects of the mine pit slopes, rock piles, and leach pads due to wind and water erosion.
2. Physical stability of the final cut and fill slope surfaces.

3. Geochemical stability of the final pit walls.
4. Water quantity and quality of seepage from the various facilities.
5. Removal and salvage of process equipment and foundations, buildings, pipelines, roads, etc.
6. Removal and salvage of site buildings related to employee housing, catering, security, administration, etc. or possible donation of same to the local community.
7. Surface water management.
8. Long-term post-closure use of reclaimed land surfaces and roadways.
9. Consideration of the donation of the San Juan de Camarones water supply reservoir to government authorities for public and social benefit.
10. Consideration of the donation of the new power lines constructed to bring power to the mine area.

The following sections describe reclamation and closure objectives and measures recommended for the Metates site and specific ancillary facilities.

18.7.1 Other Engineered Facilities

The active life of the mine pit diversion dam and reservoir, and the diversion tunnel will be extended beyond the closure phases. The entrance and outlet areas will be secured to prevent public access.

After removal of the mineralized material from the low-grade mineralized material stockpile, the upper reclaimed surfaces will be graded to drain acceptable non-contact water to the north away from the pit.

If water quality is found to be acceptable within a reasonable post-mining period of monitoring for any delayed seepage impacts such as rainwater infiltration or mine pit rising water levels, then the water treatment facility will be removed, the collection pond liner will be removed and disposed, and the pond backfilled. Related mine structures, buildings, fences, pipelines and access roads will be removed and reclaimed with vegetation for final closure.

Various other facilities and elements of the site will be removed and disposed as their beneficial use ends. Some of the facilities may remain into post closure for continuing use of the property during post closure inspections and/or turned over to local authorities for public beneficial use. Spillways that remain in use will be upgraded as necessary to safely pass long-term peak design storm flows. Closure plans will be prepared as part of future closure designs by others.

18.7.2 Closure

Closure of the Metates site will proceed in segments or at the end of operations as soon as reclamation is completed. Activities associated with closure and post-closure are described as follows.

Specific closure plans will be developed and periodically updated as needed to reflect actual construction and operating conditions related to the site facilities. A final closure plan and associated engineering details will be developed and submitted for agency review and approval.

Mexico has national environmental laws and a national regulation promulgated in 2003 (NOM-141-SEMARNAT-2003) providing guidance for the construction, operation, and closure of tailing facilities. This guidance requires that a risk assessment is submitted, that the owner has environmental insurance and that a Hazardous Waste Management Plan is registered with the authority prior to operation of the mine. These items should be developed concurrently with a pre-

feasibility or feasibility study. The direction of closure activities described herein will follow SEMARNAT guidelines. Post-closure activities will include periodic inspections, reporting, and periodic maintenance.

A program of monitoring physical and environmental stability will be implemented for a period defined by Chesapeake in the closure plan. As part of this program, inspections will be undertaken regularly by a Professional Engineer familiar with the various components of the Metates facilities and the closure objectives. The inspections will be undertaken to evaluate the conformance of closure activities with the closure plan and its objectives. Specific elements of the reclaimed Metates site that will be inspected include seepage water quality, deformation of embankments, operation of water management facilities, and conditions of final spillways.

19 MARKET STUDIES AND CONTRACTS

The Metates Project creates two value streams, namely gold and silver, which will be recovered at the Metates plant facilities:

- Gold and silver are recovered by cyanide leaching to produce doré bullion via the Merrill-Crowe recovery process

19.1 GOLD AND SILVER DORÉ

The basic treatment terms for the gold and silver doré that are incorporated into the project economic analyses (see Section 21) are based on a recent quotation from Johnson Matthey Inc., 435 Devon Park Drive, Wayne, PA 19087 USA and include the following:

- 1) Treatment Charge – US\$ 0.25 per ounce of doré received
- 2) Refining Charge – US\$ 0.75 per ounce of fine gold credited
- 3) Shipping Charges – US\$ 5,000/shipment based on 104 shipments/year average
- 4) Gold and Silver Return – 99.80% of assayed content
- 5) Settlement – 25 working days following receipt or representation

The doré bars will average about 95% silver and 5% gold by weight with other non-payable impurities.

19.2 SALES CONTRACTS

Doré bullion can be sold to refiners like Johnson Matthey and others. No specific long-term sales contracts are generally required for the sale of doré to these refiners.

Chesapeake Gold Corp. has granted to Silver Wheaton Corp. a right of first refusal on any future silver stream or royalty for which Chesapeake receives and accepts an offer to purchase, on the same terms and conditions as the third-party offer.

20 ENVIRONMENTAL STUDIES, PERMITTING AND SOCIAL OR COMMUNITY IMPACT

Baseline environmental studies were undertaken by Cambior with regard to water and air quality, biological conditions, and archaeology. Cambior also studied numerous samples of mine rock (both mineralized material and waste) for their acid generating and acid neutralization potential. This information has been summarized in the Cambior Preliminary Feasibility Study. Golder Associates completed a re-evaluation of the 1997 studies and initiated studies on new samples from the 2008 drilling. The Golder studies along with extensive testing of process related samples (tailing) and additional testing of waste rock are included in reports by InterraLogic (2015) and HydroGeoLogica (2016b). Additional discussion of testing of waste rock can be found in Section 18 of this report.

Cambior also established sixteen surface water sampling sites in the area surrounding the Metates site which were monitored twice per year. In addition, Cambior established six groundwater monitoring wells in the immediate vicinity of the deposit. Cambior sampling of these sites and wells was generally performed during the period 1995-1997. No surface water sampling or sampling of groundwater was undertaken at the Metates site between late 1997 and 2008. Schlumberger Water Services (SWS) installed new surface and groundwater sampling locations at the Metates site in 2008-2009. SWS also resampled the six groundwater sampling wells established by Cambior and has resumed dry and wet season sampling at both sites beginning in 2009. Chesapeake personnel took over these sampling efforts in 2014 but sampling ceased in 2016. An automated meteorological station was installed on-site by Cambior in 1995 but was later removed. A new meteorological station was installed at the Metates site in May 2009 and has collected nearly continuous records since that time.

Environmental baseline data collection and reporting has been completed by M3 Mexicana (M3M) for the Metates mine site (M3M, 2011a; M3M, 2012). No significant environmental issues were identified. The environmental baseline work included a survey of biological, cultural, and socio-economic resources. The results of the M3M surveys and reports are summarized later in this section. Earlier environmental baseline investigations have been performed by Woodward Clyde Consultants (Woodward Clyde, 1995) and Asesoría en Gestión Ambiental (Montenegro, 2009).

Additional collection of environmental baseline data will be required to support permitting efforts and project design. Baseline collection activities will follow guidelines and study plans established by the authorities in Mexico and "International Lending Institution Standards" to satisfy potential financing interests and requirements for the project.

The results of the M3M site visits, record review, and preliminary investigations did not reveal any issues that could be considered fatal flaws to the development of the proposed project. Additional follow-up/confirmation will be necessary as the specifics of the project are developed. Listed below is a brief discussion/overview of the individual baseline condition(s) and needs for the project.

20.1 PROJECT LOCATION

The Metates deposit is located in the northwest part of Durango State approximately 160 km northwest of Durango City, in the municipality of Santiago Papasquiaro, and about 6 km southeast of the town of San Juan de Camarones.

20.2 CLIMATOLOGY

For the Metates area, data from seventeen weather stations operated by the National Weather Service (Servicio Meteorológico Nacional) were analyzed, including temperature, precipitation, and evaporation parameters from a thirty-year period. Evaporation records were the least consistent or missing altogether. For the sake of consistency, the study relied on data from 1981 through 2014. These data were used to supplement the data derived from an on-site weather station in operation since 2009. Additional information on climate can be found in Section 5 of this report.

The rainy season begins in late May with the greatest precipitation falling in July and August, tapering off in October. During the rainy season, rain tends to fall in downpours with great intensity and short duration. Precipitation volumes

in the Metates area are related to elevation with greater amounts at higher elevations (Hatch, 2016). The average annual rainfall for the Metates area is 812 mm.

20.3 GEOLOGICAL RISK

Mexico is divided into four seismic zones according to the frequency of earthquakes in each zone and the 100-year maximum ground acceleration. The project is in a Type B, or intermediate seismic zone, where earthquakes are not frequent or they have maximum acceleration that does not exceed 70% of the ground acceleration.

The geological risk of volcanic activity is small, since there are no active volcanoes in the zone.

20.4 AIR QUALITY

The air quality at the Metates site is good. There are no known industrial pollution sources for the proposed project. The only anticipated impact of air quality on the project will come from occasional dust caused by farming activities, dust from the use of trucks and other heavy equipment on dirt roads, and the burning of fields after harvest.

20.5 SURFACE WATER FLOWS

The region around the Metates site is deeply incised by several large drainages and their tributaries. The primary drainage of the area is the San Lorenzo River. The San Lorenzo watershed area above the El Real gaging station is shown in the inset of Figure 20-1. The watershed has a total area of 7,103 km². Major tributaries of the San Lorenzo include the rivers San Gregorio, San Juan de Camarones and Los Remedios. San Juan de Camarones is the major north-south trending drainage located west of the Site. Tributaries of San Juan de Camarones near the site include (from north to south): Arroyo Pendencia, Arroyo San Nicolás, and Arroyo Camarones. Eight surface water gaging stations have been operating at the Metates site since as early as 2010 but readings ceased by 2016. The regional gaging station located on the San Lorenzo River at El Real (upstream of Comedero Reservoir) has been operating since 1978 (Figure 20-1).

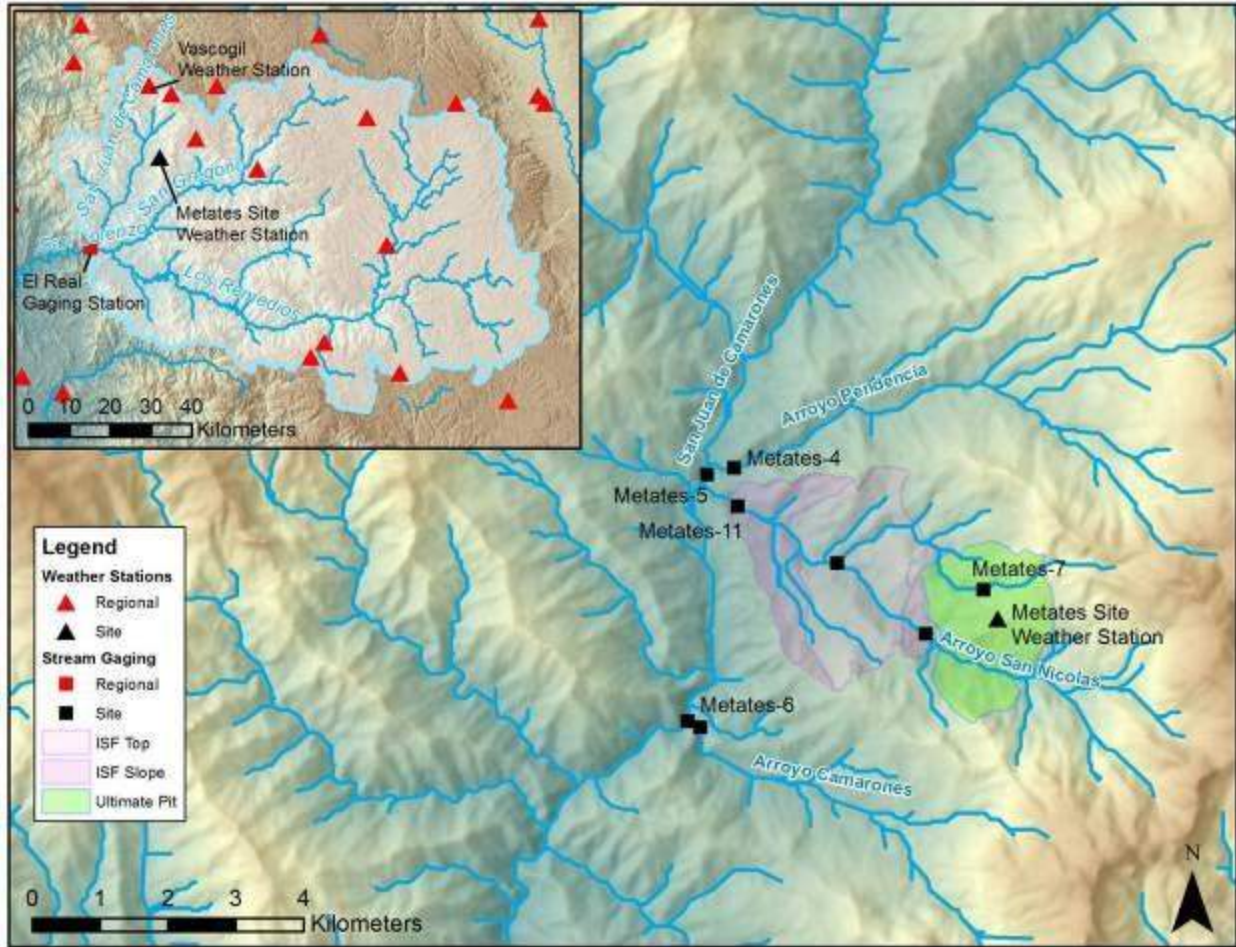

Figure 20-1: San Lorenzo River Watershed Above El Real

Twenty-two years of surface water flow data beginning in 1978 were available from Comisión Nacional Del Agua (CONAGUA) for the El Real gaging station (CONAGUA, 2013). Streamflow rates trend with occurrence of precipitation (Figure 20-2). The mean daily streamflow at the El Real station is 45 m³/sec but is highly variable. Figure 20-3 shows the historical daily streamflow observations plotted for the water year, beginning in June. Data greater than one standard deviation from the mean were removed in the calculation of the “filtered mean” to remove outliers.

Surface runoff in the project area drains to the San Lorenzo River. According to the historical data analysis, the San Lorenzo River carries an average volume of 1,403,720,000 m³/year recorded during the period 1978-2011 at the El Real hydrometric station just below the confluence of the main tributaries to the San Lorenzo (Figure 20-1). A maximum of 3,149,692,000 m³/year was recorded for the yearly runoff in 1991.

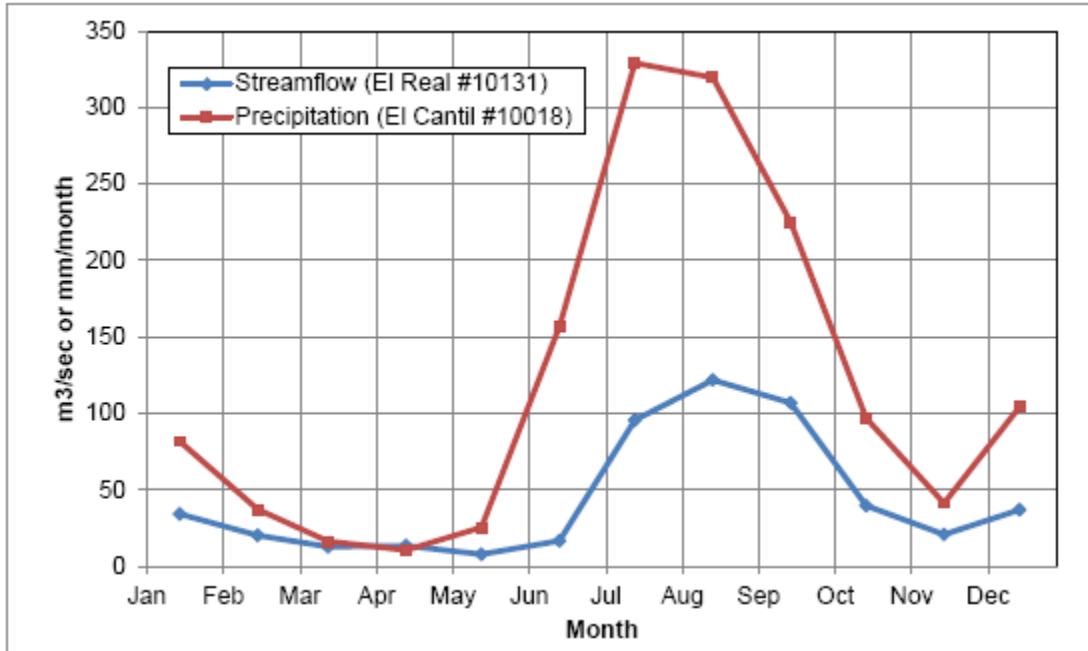

Figure 20-2: Streamflow and Precipitation in San Lorenzo Basin

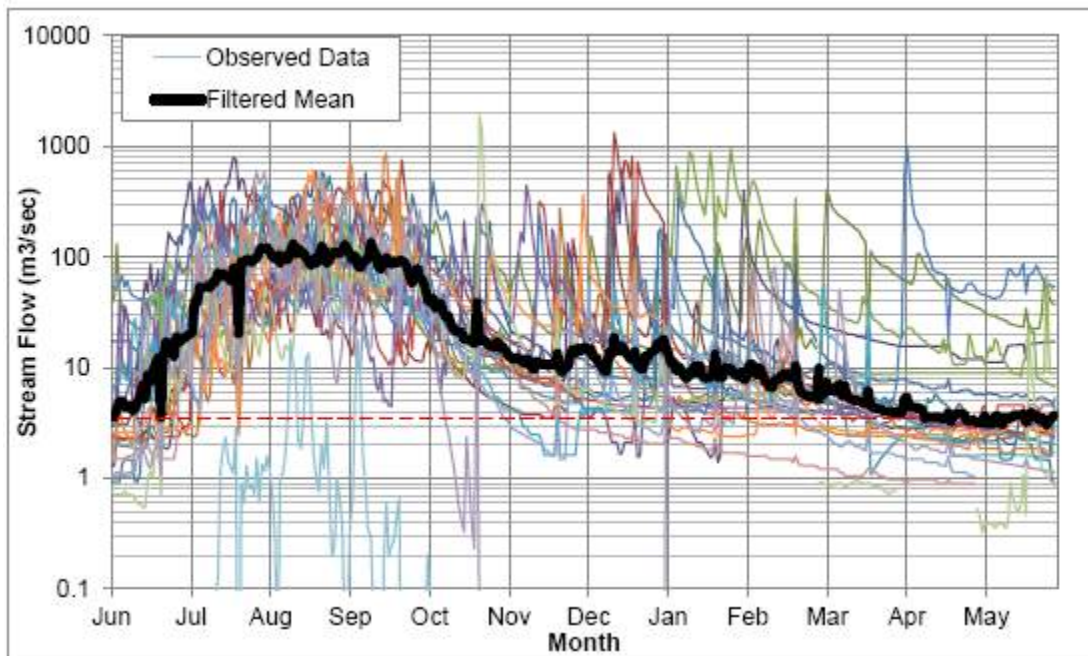

Figure 20-3: Streamflow of San Lorenzo River at EI Real

Gaging stations on several drainages near the Metates site were operated during the period 2010–2016. These gaging stations were installed by Chesapeake for estimation of streamflow used for hydraulic engineering efforts and are installed at stable stream cross-sections and consist of a stilling well and pressure transducer. Gaging station rating curves used to translate pressure to streamflow have been updated sporadically since installation. Streamflow at these gaging stations has the same seasonal pattern as noted at the EI Real station. Review of streamflow and precipitation

data during an evaluation of rainfall-runoff coefficients indicates that the rating curves have not remained calibrated over the period and the streamflow data are therefore of limited use (Hatch, 2015). Site-wide seasonal runoff coefficients were estimated from two of the better-calibrated stations and the averages range from 6.5% during the wet season to 14% during the dry season (Hatch, 2015). Estimates of streamflow were made at two gaging locations during a site visit in early June 2014, prior to the beginning of the wet season, flow was estimated as 144 liters per second (L/s) at Metates-5 and 0.67 L/s at Metates-7 (Figure 20-1).

Most of the runoff to the San Lorenzo River and its tributaries is generated during the summer rainy season from June to October each year during the hurricane season. The San Lorenzo River basin averages one hurricane type storm every five years. Light winter rains ("Equipatas") and snowmelt from the higher portions of the basin contribute to runoff during the winter months.

20.6 VEGETATION

Together, the topography, elevation, and soil types of the area create distinct microenvironments distinguishable by the types of vegetation they support. Some areas may be inhabited by species of trees suitable for logging and wood pulp some of which may provide the habitat and food source for various organisms, such as birds and mammals, some of them endemic to the area.

The higher elevations in the Metates area support mesquite-huizache forest, oak forest, and pine forest. Areas of introduced vegetation in farmed fields or cleared areas may be interspersed among these natural vegetation areas. The list of plant species indicated as possibly being present at the Metates site includes several belonging to at risk Priority 1, 2, and 3 ranking classifications. As such, a vegetation management plan needs to be prepared to mitigate any negative impacts to these at risk species.

20.6.1 Flora Management Plan

An understanding of the planned stages for advance clearing is important in order to develop strategies for tagging and rescuing species as may be necessary based on their species ranking. Before any clearing takes place in the area, field technicians will conduct an extensive tour of the site and will tag the species to be rescued with brightly colored tape easily seen from a distance. Areas in which plants are being tagged will be mapped, and the species to be rescued will be accounted for in a preliminary inventory. Following these preparations, the ground crew will proceed with transplanting the species, using both manual tools and motorized equipment.

Priority 1, Species listed in NOM-059-SEMARNAT-2010

The company will make every effort to ensure the rescue of each individual species, whether by taking seedlings, cuttings, or specimens of adequate size. Of greatest priority, are those fragile species whose survival in the area is critical to biodiversity.

Priority 2, Slow-growing Species

Priority 2 species are typically members of the cactus family. The rescue of younger cacti involves the following procedures:

- Remove the whole specimen including roots by hand using a gardening spoon, pick, or shovel to avoid damaging it.
- Mark the orientation with respect to the sun to ensure improved replanting success.
- Trim long roots to $\frac{1}{3}$ of their original length to promote the growth of new roots.

- Rinse with tap water and remove dirt to reveal any damage from removing the species, and to detect the presence of pests or parasites.
- Using a sharpened knife that has been disinfected first with alcohol, then by flame, remove any pest-damaged sections.
- Transfer the plants to a temporary nursery in uncovered boxes or crates to avoid excessive desiccation.
- Allow the plant to dry and heal for up to 15 days in a cool, shaded, and well-ventilated area.

Priority 3, Rescue of Other Listed Species

For species not included in the Priority 1 or 2 groups, the company will evaluate the feasibility of rescue and will establish the number and type of species to be included in the plant protection program. Some species of interest may need to be grown in a nursery to determine what efforts for protection will be necessary.

20.7 WILDLIFE

The list of wildlife species potentially found in the area of the Metates site includes 340 bird species, 55 mammal species, 57 reptile species and 33 amphibian species. Of these, 33 bird species, 10 mammal species, 24 reptile species, and 7 amphibian species are classified in an at-risk category by the Mexican Official Regulation NOM-059-SEMARNAT-2010. A wildlife management plan needs to be prepared to mitigate any negative impacts to these at risk species.

20.7.1 Wildlife Management Plan

To determine the wildlife present in the project area, a list will be prepared that is categorized by risk based on NOM-059-SEMARNAT-2010 and species considered to be important for the Convention on International Trade in Endangered Species of Wild Fauna and Flora (CITES). The following procedures are recommended.

- Locate areas on a 1:50,000 topographic map with the greatest abundance of habitat for each group of vertebrates and select potential sites for their relocation and conduct an inspection tour to locate any possible fauna nests or burrows.
- For the duration of the project, drive away any animals found near the working areas.
- Maintain records or evidence of the rescues performed using record sheets, digital camera, video camera, or other means.
- Transfer and relocate rescued animals to a strategically selected site that provides conditions similar to the former habitat.
- Note that any collection, hunting, trading, or other activity by project personnel that affects the wildlife of the region is strictly prohibited.
- Previously captured wildlife will be relocated to an area near the project but outside of the radius of the direct and indirect activities of the project. These areas shall provide conditions similar to the original habitat.
- The reason for not relocating captured specimens to distant areas (well beyond areas directly and indirectly impacted by the project) is related to the following factors: to avoid moving animals with particular genetic patterns to other environments, to ensure that the new habitat chosen has physical conditions similar to those of the original habitat, and to prevent animals from being in captivity for prolonged periods of time.
- Sites with conditions similar to those of the original environment will be selected.

**METATES SULPHIDE HEAP LEACH PROJECT - PHASE 1
FORM 43-101F1 TECHNICAL REPORT**

- Once the wildlife have been cleared and chased away, monitor the presence and abundance of specimens in the area.
- Confirm the absence of wildlife in cleared areas. If wildlife is detected after having implemented the plan to drive it off, execute a rescue and relocation plan for animals that did not relocate naturally.
- Monitoring will focus on specimens of the rescued species in the final relocation sites. The specimens detected will be visually recorded but will not be handled. Also, all indirect evidence of animals, such as tracks, excretion, and remains, will be recorded.

20.8 ENVIRONMENTAL CONSERVATION AREAS CLOSE TO THE PROJECT

The Metates Project does not intrude on any of the Federal Natural Protected Areas (ANP's) or related conservation areas decreed by the Diario Oficial de la Federación (Figure 20-4). However, there are land regions in which there is a great diversity of habitats for different plant and animal species, so it will be necessary to conduct detailed surveys to define the specific construction strategies for these areas.

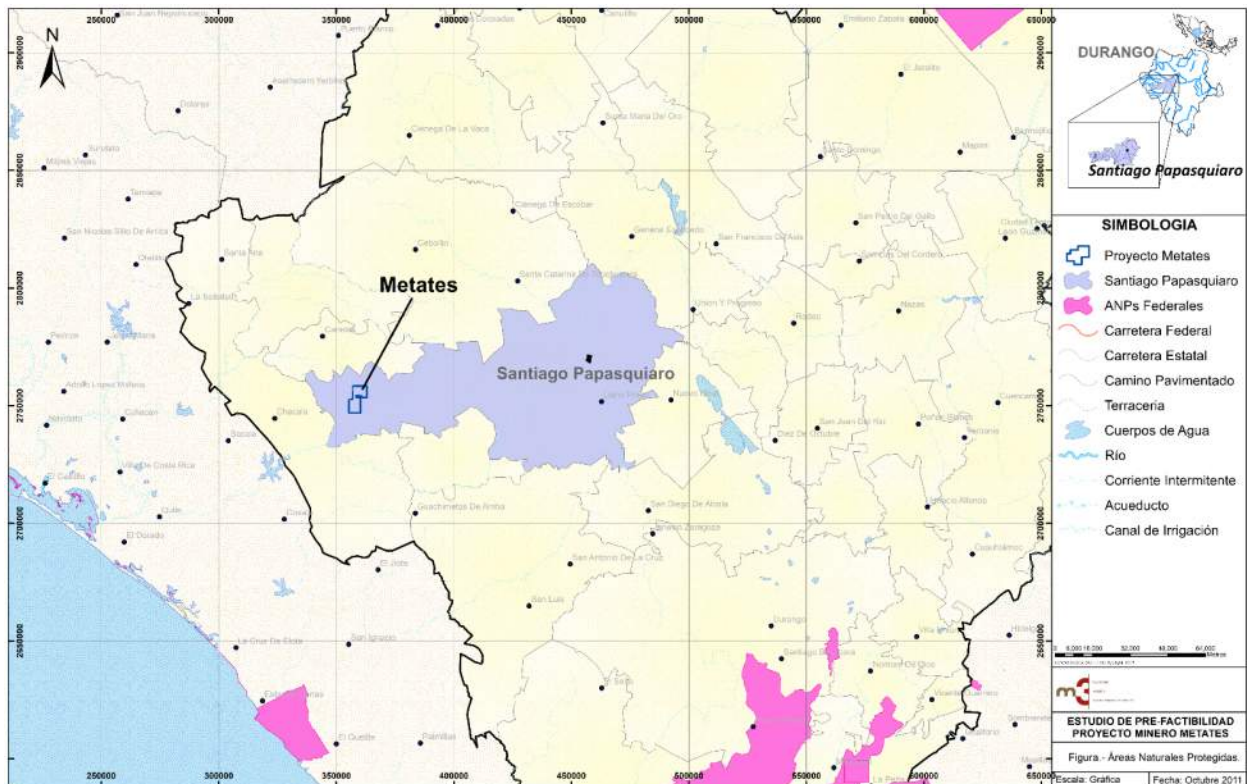

Figure 20-4: Natural Protected Areas (ANP Federales)

20.9 SOCIO-ECONOMIC BACKGROUND

The project is situated in a rural area within Durango State. The economy relies on rain-based farming and extensive cattle ranching. Salaries and overall standard of living in the area of the project are generally low. The Metates Project offers the opportunity for higher-paying jobs with increased community resources and access to services in the region— an overall improvement to the local and regional economy.

A five-year agreement was signed in October 2008 between the community of San Juan de Camarones and Chesapeake that will allow for exploration-related activities and calls for annual payments, as well as the obligation to improve and maintain the roads in the area. A new agreement has recently been signed that will extend the right to perform exploration related work at the Metates site through September 2025, as discussed further in Section 4.3 of this report.

A proposed mining operation at the Metates site would likely be disruptive to the village of Vascogil, requiring all or part of it to be relocated. Lesser direct impacts would be anticipated for the village of San Juan de Camarones and the surrounding villages of El Naranjito and San Miguel el Alto. The introduction of a large mining operation into this rural area will bring increased employment opportunities as well as improved infrastructure in the form of roads, power, water, and sanitation. In addition, improved schools and medical facilities can also be anticipated. A residential camp for workers will be developed near the Metates process facilities with a capacity for more than 500 occupants at any one time. The residential camp will minimize direct disruptions to the nearby villages.

Chesapeake has had extensive and on-going discussions with representatives from the State government of Durango and plans to continue these discussions in the future. As defined in this study, Durango State will gain a significant amount of capital investment as well as thousands of direct and even more indirect jobs owing to proposed mine development at the Metates site. Durango is very supportive of the future development of the Metates Project and have pledged to support Chesapeake in any way they can.

Chesapeake personnel have held numerous meetings with members of the ejido of San Juan de Camarones (Metates) and plan to continue an active program of community and stakeholder engagement. Chesapeake has made donations to the ejido for various shared improvements above what is called for in any formal agreement.

20.10 CULTURAL AND HISTORICAL ASPECTS

During the M3M site visit, no culturally nor historically significant sites or artifacts were observed within the project areas. While there is evidence of historical mining, no site is considered to be significant or worthy of protection.

A formal inventory will be required to support permitting efforts. This inventory will need to be performed prior to submission of formal permitting documents.

20.11 PERMITTING CONSIDERATIONS STATUS

Chesapeake has acquired all the necessary permits to perform the exploration works undertaken at the Metates site. This included an agreement with the local surface owners that Chesapeake could access the land to perform its work, and permits from the Mexican government environmental agency, SEMARNAT.

No formal permitting activities or documents regarding mine development or operation have been undertaken or submitted to the various governmental agencies, but an environmental and permitting overview and fatal-flaw analysis was commissioned by Chesapeake and was published in 2009 (Montenegro, 2009).

20.11.1 Permits

For the most part, federal laws regulate mining in Mexico, but there are some aspects subject to state or local approval. The SEMARNAT is the chief agency regulating environmental matters in Mexico. CONAGUA has authority over all matters concerning water rights and activities that affect ground and surface water, including diversion of floodwaters.

Permit applications will be submitted for the Metates site. Table 20-1 shows the key permits required, the development stage during which the permit is required, the responsible government agencies, and the estimated approval time.

Three SEMARNAT permits are mandatory to begin construction: the Environmental Impact Manifest (MIA), the Change of Land Use (CUS), and a Risk Analysis (RA). A land use license from the local municipality and an archeological release letter from National Institute of Anthropology and History (INAH) are also required before starting construction. Each of the listed permits is discussed briefly below.

Before issuing a CUS permit, the Mexican government requires the company to have secured a federally approved occupation agreement (sale or temporary occupation agreement) with the land owner or owners (ejidos or communities) covered under the land use permit.

New power lines and roads must also undergo the permitting procedure. However, neither power lines nor roads are subject to the requirement for a risk analysis (see discussion below).

Mine permitting in Mexico is generally straightforward and should not take more than 12-18 months from initial permit application to approval. A properly prepared application document can be reviewed and approved in less than six months unless special circumstances exist, such as significant local opposition or impacts on designated ecological or natural resources.

20.11.1.1 Environmental Impact Manifest

All new projects, mining and otherwise, require an approved environmental impact manifest (MIA). It establishes the project site baseline conditions for plant and animal life, soil, water, and air quality. The study also identifies potential impacts of mine operations on the environment together with recommended mitigation measures.

Other permits and approvals, such as water rights and local approvals, are contingent upon MIA approval.

Much of the MIA is devoted to socioeconomic matters. Mexico emphasizes protection of communities and development of infrastructure in affected communities. The project owner will be expected to fund expansion of services and facilities, such as schools, water supply, sanitation, security and police protection, roads, and other community components.

20.11.1.2 Change of Land Use Application

All land in Mexico has a designated use, and any project areas not currently designated for mining must undergo a procedure to change the designation. The Change of Land Use (CUS) application is the formal instrument for changing the designation to allow mining.

The CUS program stems from the Forestry Law and its regulations. It requires an evaluation of the existing conditions of the land, including a plant and wildlife study, an evaluation of the current and proposed use of the land and impacts on natural resources, and an evaluation of plans to protect and save topsoil and certain plants and animals. A CUS will not be granted without a positive demonstration of agreements with all affected surface land owners. In addition, a CUS will not be granted without a reclamation bond being posted in the name of the federal government. The amount of the bond is based on the land area itself as well as the value of the existing land and use.

20.11.1.3 Risk Analysis

A Risk Analysis (RA) study is required in accordance with Federal Law and certain lists of presumptively risky activities officially published by SEMARNAT. The law covers facilities that handle reportable quantities of hazardous materials. All but the smallest mining operations require submittal of a RA. In a RA, all environmental risks are identified and evaluated to establish the methods that will be used to prevent, respond to, and control environmental emergencies.

20.11.1.4 Water Permitting

The National Water Law and its regulations control all water use in Mexico. Applications are submitted to CONAGUA, declaring the annual water needs for the mine operation and the source of water to be used. CONAGUA grants water concessions according to the availability in the source area.

CONAGUA must also approve any activities in floodplains, including the diversion of floodwaters around the mining and processing facilities.

Water related matters will likely be handled by the CONAGUA office in Durango for activities at the Metates site. The official response time for a water use application is 90 days. Any water discharge system, such as septic tanks, must also be registered with this agency.

20.11.1.5 Land Use License

A Land Use License is a municipal endorsement to develop the mining project within the municipal land jurisdiction. This procedure is important to avoid any future conflict with the use of the land and derives from the Human Settlement Law and the Municipal Urban Development Plans for each municipality.

20.11.1.6 Explosives Handling

The Explosives and Firearms Law is the legal instrument regulating the use, storage, and manufacture of explosives. Secretaría de la Defensa Nacional (SEDENA) is the oversight agency for any explosives handling activity.

In general, Mexico's Military (SEDENA) issues explosives permits. The permits also require endorsement of the State government and the municipality. An application is to be submitted at SEDENA offices in Mexico City, indicating the type and amount (annual consumptions) of explosives. While magazine construction drawings will be included in this application, SEDENA will issue the permit only after inspecting the actual magazine.

20.11.1.7 Cultural Resources

The Instituto Nacional de Antropología e Historia (INAH) oversees archaeological evaluations and provides clearance for a project once studies and any required mitigation are complete. INAH will perform the review and field evaluation quickly and at no cost other than transportation and lodging for their investigators.

Table 20-1: Permits Matrix

Permit	Agency	Date Required by:	Description / Comments	Agency Fee (Mexican pesos)	Agency Process Time	Prepared by
Environmental Impact Manifest	Secretaria de Medio Ambiente y Recursos Naturales (SEMARNAT) Environmental Impact and Risk Department SEMARNAT Durango Office Distrito Federal Office	Prior to construction	Description of technical and environmental characteristics of the project; Indicating if the project corresponds to a new development area, expansion, modification, replacement or rehabilitation of mining infrastructure; Indicating the activities to be developed such as exploration, exploitation or benefit of the main minerals of the project. Environmental System and Socio-economic description; Description of problems detected in the project area. Identify the activities that may cause ecological imbalance. Preventive and mitigation measures for environmental impact.	Per application A \$ 36,900.35 B \$ 73,802.43 C \$ 110,704.53 May 2021 A, B, or C according to Annex 1	Approximately 90 days	M3M & subcontractor
Risk Analysis If the project has risk factors included the first or second high risk activities list	Secretaria de Medio Ambiente y Recursos Naturales (SEMARNAT) Environmental Impact and Risk Department SEMARNAT Durango Office Distrito Federal Office	Prior to construction	Analyze natural and socioeconomic resources. Detailed description of process. Detailed description of Civil, Mechanical, Electrical, and Fire Protection Engineering. Verification of Auxiliary Process and Equipment. Matter and energy balance. Analysis of work temperatures and pressures. Physical state of various process flows. Characteristics of Operating system installation. Piping and Instrumentation Diagrams (P&ID) with detail engineering. Methodology for identification and classification. Potential affected radii and risk interactions.	Per application Level 0 \$1,349.40 Level 1 \$2,063.93 Level 2 \$3,056.53 Level 3 \$4,193.94 May 2021	Approximately 90 days	M3M & subcontractor
Land Use Change	Secretaria de Medio Ambiente y Recursos Naturales (SEMARNAT) Forestry Resources Department SEMARNAT Durango Office	Prior to construction	Basic information about the project. Analyze natural and socioeconomic resources. Environmental System and Socio-Economic description and problems detected in project area. Identify the vegetation species that may be endangered by removing topsoil. Locate the protected species to conserve the habitat. Determine possible problems from removing vegetation cover. Identify the activities that may generate an ecological imbalance. Propose preventive and mitigation measures for environmental impacts. Permit: In areas with arid and semiarid climate, \$7,221.16 pesos/deforested hectare will be contributed to the Mexican Forest Fund multiplied by the environmental criteria index.	May 2021 Per inspection 1-10 ha. \$1,773.75 10-50 ha. \$3,744.61 50-200 ha. \$7,489.21 >200 ha. \$11,430.90 Total cost depends on number of hectares affected and type of vegetation	Approximately 90 days	M3M & subcontractor

METATES SULPHIDE HEAP LEACH PROJECT - PHASE 1
FORM 43-101F1 TECHNICAL REPORT

Permit	Agency	Date Required by:	Description / Comments	Agency Fee (Mexican pesos)	Agency Process Time	Prepared by
Archaeological Release Letter	INAH (Durango office)	Prior to construction	Any work performed near archeological, artistic or historic monuments should be previously authorized by the INAH	Cost not specified.	Approximately 120 days	M3M
New Concession or Approved Use of Underground Water	Secretaria de Medio Ambiente y Recursos Naturales (SEMARNAT) Comisión Nacional del Agua (CNA)	Prior to Construction	When it is required to exploit, use, or take advantage of ground water in areas that, due to public interest, Federal Executives have regulated, closed, or declared restricted.	\$4,338.63 May 2021	Approximately 90 days	
Titles and Registration Transfer Authorization	Secretaria de Medio Ambiente y Recursos Naturales (SEMARNAT) Comisión Nacional del Agua (CNA)	When required	When the holder of a concession title or current assignment of rights registered in the water rights public record and wants to transfer those rights, in the case of surface water within the same basin or underground water within the same aquifer.	\$3,998.99 May 2021	Approximately 90 days	
Concession for the Extraction of Materials from Rivers Deposits	Secretaria de Medio Ambiente y Recursos Naturales (SEMARNAT) Comisión Nacional del Agua (CNA) A MIA approved by SEMARNAT is needed to grant the Concession.	When required	When it is required to exploit the construction materials located in national territory as referred to in the following fractions of the National Water Law Article 113, When the administration is in charge of the National Water Commission: The lands occupied by lakes, lagoons, estuaries or natural deposits with water that is considered national property; and The river bed.	\$1,838.04 May 2021	Approximately 90 days	
Concession for Federal Land Occupation Under the Jurisdiction of the National Water Commission	Secretaria de Medio Ambiente y Recursos Naturales (SEMARNAT) Comisión Nacional del Agua (CNA)	When required	Use of channels, river beds, lakes or lagoons, as well as estuaries, and other national goods regulated by the National Water Law	\$1,839.01 May 2021	Approximately 90 days	
Use of Explosives (presented for evaluation)	Secretaria de la Defensa Nacional (SEDENA)	For procurement, transportation, storage or use of explosives	An application is submitted in Mexico City with the following attached to the application form: Notification Letter from the State Governor. Municipality Security Certificate. Powder magazine location map with reference to any human settlement sites. Relation between the type of explosives and quantity used monthly. Company's legal documentation.	\$15,941.07 pesos In some cases, the letter from the State Governor and the Municipality Security Certificate has an additional cost to that of the SEDENA May 2021	Approximately 90 days after the technical inspection by SEDENA personnel	M3M
Flora and Wildlife Management Plan	Secretaria de Medio Ambiente y Recursos Naturales (SEMARNAT)	Prior to Land Clearing	Rescue program for flora and wildlife that are endangered and under special protection	None	30 days	M3M & subcontractor

METATES SULPHIDE HEAP LEACH PROJECT - PHASE 1
FORM 43-101F1 TECHNICAL REPORT

Permit	Agency	Date Required by:	Description / Comments	Agency Fee (Mexican pesos)	Agency Process Time	Prepared by
	SEMARNAT State Office					
Compliance with Environmental and Risk Regulations	Secretaria de Medio Ambiente y Recursos Naturales (SEMARNAT) Procuraduría Federal de Protección al Ambiente (PROFEPA) State Office	Always	The authorization in the Environmental Impact and Risk Analysis defines the guidelines for the construction and start-up of operations to protect the environment	None		M3M
Waste Water Discharge	Secretaria de Medio Ambiente y Recursos Naturales (SEMARNAT) Comisión Nacional del Agua (CNA)	Before discharging water	When waste water is discharged permanently, intermittently, or at random into national water bodies as well as when it infiltrates lands that are national assets or other land where it can contaminate the soil or aquifers	\$5,942.09 May 2021	90 days	M3M & subcontractor
Construction License	Municipality	Prior to construction	Must comply with construction standards	Varies	Check with Municipality	subcontractor
Land Use License	Municipality	Prior to construction	The project must be registered and approved by the Municipality.	Varies	Check with Municipality	subcontractor
Hazardous Waste	Secretaria de Medio Ambiente y Recursos Naturales (SEMARNAT) State Office	Prior to construction	Those who produce hazardous waste must be licensed. Producers are responsible for ultimate safe disposal of wastes.	\$790.40 May 2021		
Unique Environmental License	Secretaria de Medio Ambiente y Recursos Naturales (SEMARNAT) State Office	Six months after operation start-up	Required for new operations, expansions of existing operations or operations that require regulation.	\$2,956.27 May 2021	60 days	M3M & consultant

20.12 SURFACE AND GROUNDWATER INVESTIGATIONS

The goal of the surface and groundwater sampling program is to characterize the pre-mining or pre-operations surface and groundwater conditions at the Metates site. This information is required to be included as part of the permitting applications to SEMARNAT. Information typically is in the form of stream flow and water quality/chemistry data for surface water sampling sites and chemistry and ground water elevations for groundwater samples that typically come from installed ground water wells but can include natural springs.

At the Metates site, baseline information on both surface and groundwater was collected by Cambior during the period 1994-1997. In 2010, SWS established new surface water and groundwater sampling locations at Metates that cover the same general area as the older sampling sites and has also resampled the same groundwater wells established during the older period. This recent sampling program ceased in 2016. A longer period of effective baseline conditions can be established by sampling these new sites and comparing these results with the older data.

Sampling periods during 1994–1997 by Cambior were typically quarterly. Sampling by Chesapeake has been performed twice or three times per year in recognition that the seasonal variation in rainfall only requires that the sites be sampled at least once during the wet season and once during the dry season to capture any variations. A water quality (surface and groundwater) database that includes the data from all the Metates sampling sites from 1994 to 1997 and then from 2010 to 2016 has been prepared by HydroGeoLogica (2016a).

20.12.1 Surface Water Investigations

SWS prepared a sampling and analysis plan for the surface water baseline investigations (SWS, 2013). This plan specifies the monitoring of the metals and general parameters derived from the Mexican Official Standard NOM-127-SSA1-1994 which establishes for public water systems the permissible limits of water quality and drinking water treatments for human use and consumption. Figure 20-5 shows the surface and groundwater sampling locations at the Metates site that are part of the current sampling program as well as basic sampling results obtained in August 2012.

Several sets of water quality results from previous Metates surveys in 1994, 1995, 1996, and 1997 were compared with the more recent data in 2011 and 2012 with the following results:

- Metates 4: Good water quality. All results were below the official Mexican standard maximum contaminant levels (MCL) for surface water.
- Metates 5: Good water quality. All results except cadmium were below the official MCL. The result for total cadmium was 0.0078 mg/L. The MCL is 0.0050 mg/L. Cadmium will continue to be monitored at this site.
- Metates 6: Good water quality. All results were below the official MCL.
- Metates 9: Good water quality. All results were below the official MCL.
- Metates 11: Good water quality. All results were below the official MCL.

Seasonal surface water quality trends comparing sulfate levels between the Metates-11 and Metates-4 sites, which share similar flow volumes, depicts a much higher discharge of sulfate to the Arroyo San Juan de Camarones from the Arroyo San Nicolas Drainage (downstream from the Metates deposit) than from the Arroyo Pendencia drainage. There are fairly consistent sulfate concentrations from the Metates-5 site down to the Metates-9 in the Arroyo San Juan de Camarones. Water chemistry tends to vary on a seasonal basis as would be expected, and these trends are consistent for water samples collected during the 1990's to the more recent samples from 2015.

The water discharge volume is monitored with stream gages installed within the streambed. SWS and Chesapeake installed three stream stage monitoring stations in July 2009 near the proposed pit area and expanded the monitoring network at Metates in March 2011 to a total of eight stations. The monitoring systems use water depth and field measurements of channel cross section to provide an approximation of flow volume. The calculated flow volumes are based on stream stages. Pressure transducers with data logging capabilities (Diver® data loggers) record water depth readings at 5-minute intervals. The water depths are used with surveyed channel profiles at the gauging stations to estimate flow.

River gage measurements have been collected for Metates gage Stations 7, 8 and 10 from June 2009 until 2016, while Stations 4, 5, 6, 9, and 11 were monitored starting in July 2011 also ending in 2016. Adjustments to the flow volume calculations are still considered as the network is occasionally calibrated with flow velocity measurements. Comparison of some of the stream gaging measurements with the storm events as measured at the Metates site suggest some of the stations need to be re-calibrated, likely because of changes to the stream cross sections at the measurement site (Hatch, 2016).

METATES SULPHIDE HEAP LEACH PROJECT - PHASE 1
FORM 43-101F1 TECHNICAL REPORT

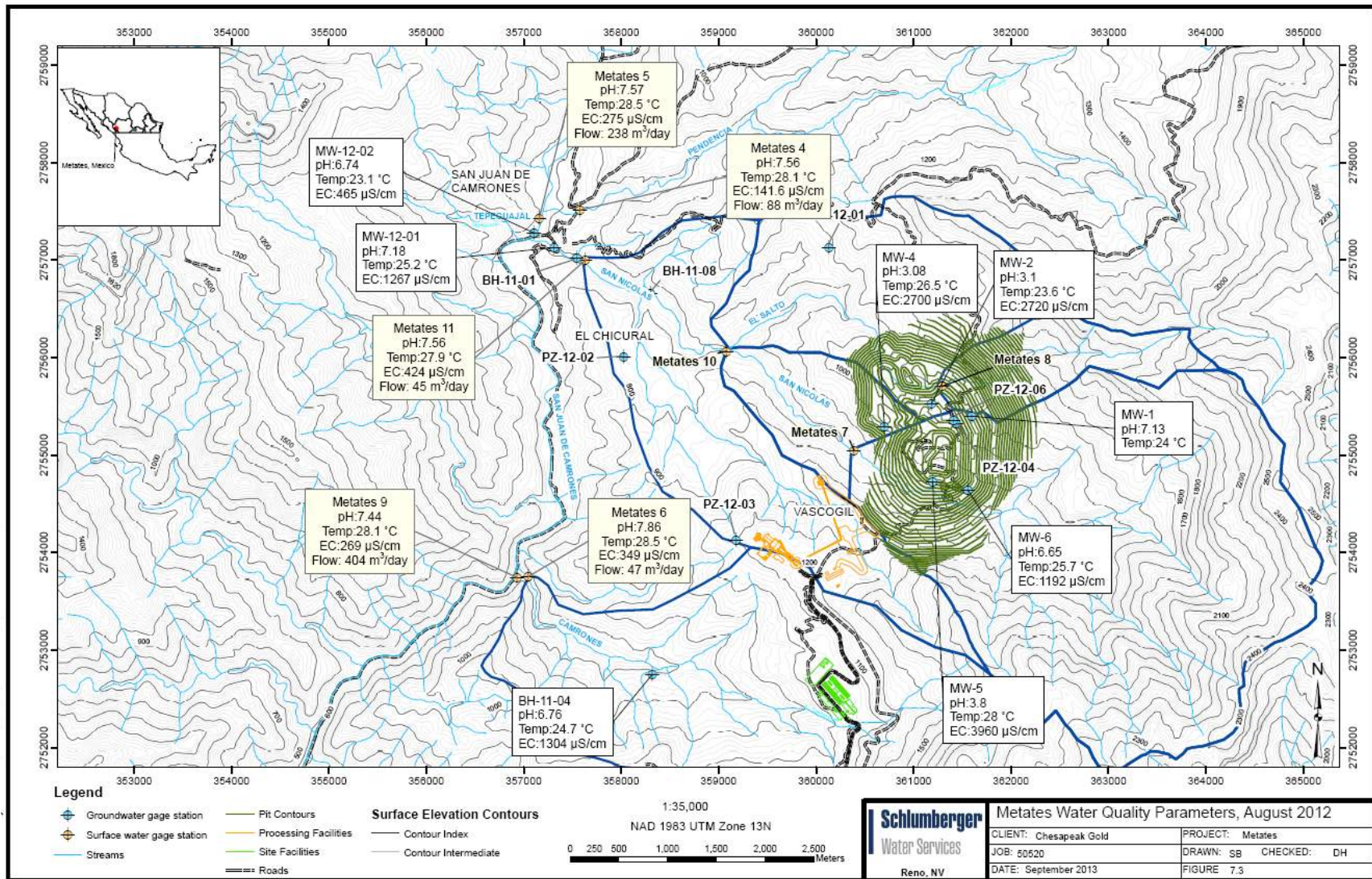

Figure 20-5: Surface Water and Groundwater Sampling Locations as of 2012

20.12.2 Groundwater Investigations

Two environmental monitor wells were constructed at the Metates site in 2012 near the confluence of the Arroyo San Juan de Camarones and Arroyo San Nicolas: MW12-01 and MW-12-02. MW-12-01 monitors groundwater quality near the mouth of Arroyo San Nicolas before it discharges into Arroyo San Juan de Camarones, and MW-12-02 monitors background groundwater quality upstream of the confluence in Arroyo San Juan de Camarones. A third well, BH-11-04 located in Arroyo Camarones, has been re-designated for baseline groundwater sampling.

Three piezometers were constructed utilizing condemnation boreholes that had encountered groundwater and were at a distance and orientation to enable interpretation of the groundwater gradient and flow direction across the Metates site.

Locations of the groundwater monitoring sites are shown in Figure 20-5, including the older Cambior sites (MW-1 thru -6). The purpose of the monitor wells is to evaluate the groundwater flow direction and gradient and permit sampling of the shallow groundwater for baseline groundwater quality characterization.

Figure 20-6 presents a summary of the interpreted groundwater elevations for the monitor and piezometer wells in the Metates area (Hatch, 2015). The groundwater elevations mimic the surface topography, with depths to groundwater ranging from only a few meters to a maximum of 143 m.

A site well summary for Metates is provided in Table 20-2; including construction specifications. Results for the August 2012 field measurements for the sixteen environmental monitor wells and piezometers are also included as representative baseline data for the wet season. Water chemistry tends to vary somewhat on a seasonal basis, and these trends are consistent for groundwater samples collected during the 1990s to the samples from 2014. Samples collected from monitor wells within the mineral resource area typically have higher concentrations of iron, sulfate, TDS, etc. and lower values for alkalinity and pH than water samples from wells outside the resource area. No groundwater sampling or related investigations have been performed since 2016.

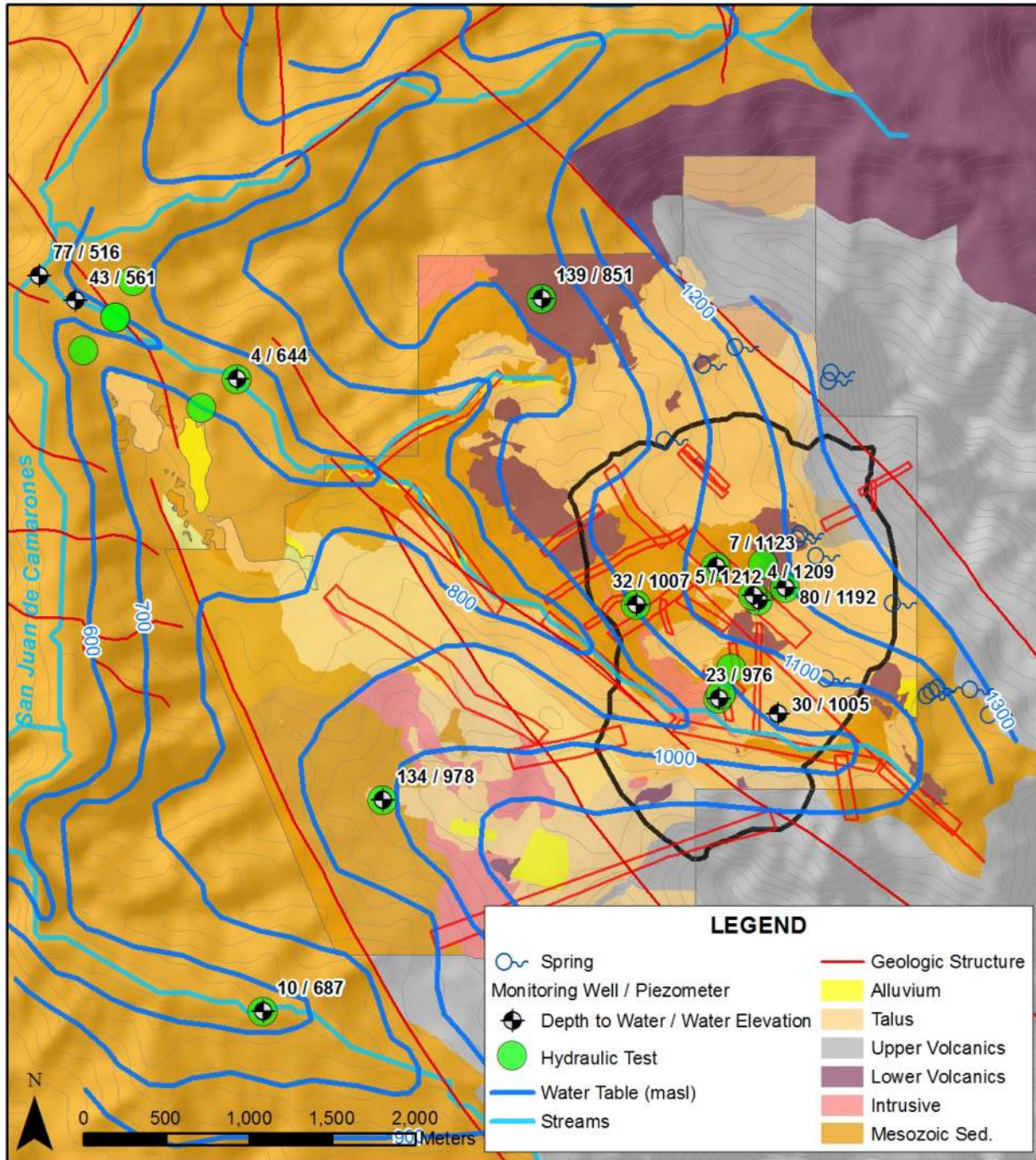

Figure 20-6: Bedrock Geology and Interpreted Groundwater Elevations

Table 20-2: Groundwater Wells and Field Parameters

Well ID	Easting (UTM NAD 83)	Northing (UTM NAD 83)	Land Surface Elevation (masl)	August 2012 Static Water Level (mbtoc)	PVC Stickup (mals)	Water Surface Elevation (masl)	Field Parameters			
							Date	Temp. C	pH	Conductivity (µS/cm)
Metates										
BH-11-01	357542	2757019	608	3.98	0.84	604.86	-	-	-	-
BH-11-04	361436	2755324	1,219	9.84	0.5	1,209.66	8/20/2012	24.7	6.76	1,304
BH-11-08	358299	2756662	664	5.38 (6/12/12)	0.62	658.62	-	-	-	-
MW-12-01	357313	2757129	604	4.78	0.6	599.82	8/19/2012	25.2	7.18	1,267
MW-12-02	357103	2757278	597	4.53	0.8	593.27	8/20/2012	23.1	6.74	465
MW-1	361596	2755397	1,285	80.14	0.8	1,205.66	8/17/2012	24.0	7.13	No Measurement
MW-2	361183	2755528	1,137	6.90	0.83	1,130.93	8/18/2012	23.6	3.10	2,720
MW-4	360700	2755296	1,043	32.63	0.86	1,011.23	8/18/2012	26.5	3.08	2,700
MW-5	361195	2754730	1,014	23.10	1.01	991.91	8/18/2012	28	3.80	3,960
MW-6	361556	2754643	1,047	29.64	0.85	1,018.21	8/18/2012	25.7	6.65	1,192
PZ-12-01	360130	2757130	992	43.98	0.5	948.52	-	-	-	-
PZ-12-02	358024	2756008	752	29.80	0.5	722.70	-	-	-	-
PZ-12-03	359177	2754128	1,114	76.61	0.5	1,037.89	-	-	-	-
PZ-12-04	361436	2755324	1,221	136.68	0.53	1,084.85	-	-	-	-
PZ-12-06	361408	2755357	1,218	143.15	0.5	1,075.35	-	-	-	-
masl – meters above mean sea level										
mals – meters above land surface										
mbls – meters below land surface										
mbtoc – meters above top of pvc casing										
<div style="display: flex; align-items: center;"> <div style="width: 15px; height: 15px; background-color: yellow; margin-right: 5px;"></div> Environmental Monitoring </div>										
<div style="display: flex; align-items: center;"> <div style="width: 15px; height: 15px; background-color: lightblue; margin-right: 5px;"></div> Water Level Monitoring </div>										

20.12.3 Hydrogeologic Modeling

A groundwater field investigation program was initiated by SWS during 2012 to characterize the hydrogeologic conditions near the proposed Metates open pit, including groundwater flow direction, recharge/discharge mechanisms and rates, and rock hydraulic properties such as permeabilities and storage capacity. In addition to hydrogeologic conditions, groundwater quality was also to be assessed as a baseline study. Data collected during this program will be used to assess the expected pumping rates required for future mine dewatering wells, post-closure pit water level recovery rates, pit lake formation, equilibrium pit lake water levels and expected water quality. More recent groundwater investigations are described by Hatch (2015 and 2016) for the groundwater modeling and pit lake modeling, respectively.

Six airlift tests and ten slug tests were conducted at the Metates Project during 2014 at the borehole locations shown on Figure 20-7. The airlift tests were conducted at multiple depths in three exploration boreholes drilled during 2013. The tests were conducted by measuring the water level response in the borehole after the borehole was evacuated using compressed air (air lifting). The slug tests were conducted on ten existing monitoring wells and piezometers with total depths ranging from 15 to 170 m. Test were conducted by rapidly pouring a “slug” of water down the well casing while monitoring the change in water level using a data-logging water-level transducer. The size of the slug ranged from 100 to 200 liters. Unless immediate recovery was indicated, most slug tests were monitored for a minimum of 8 hours.

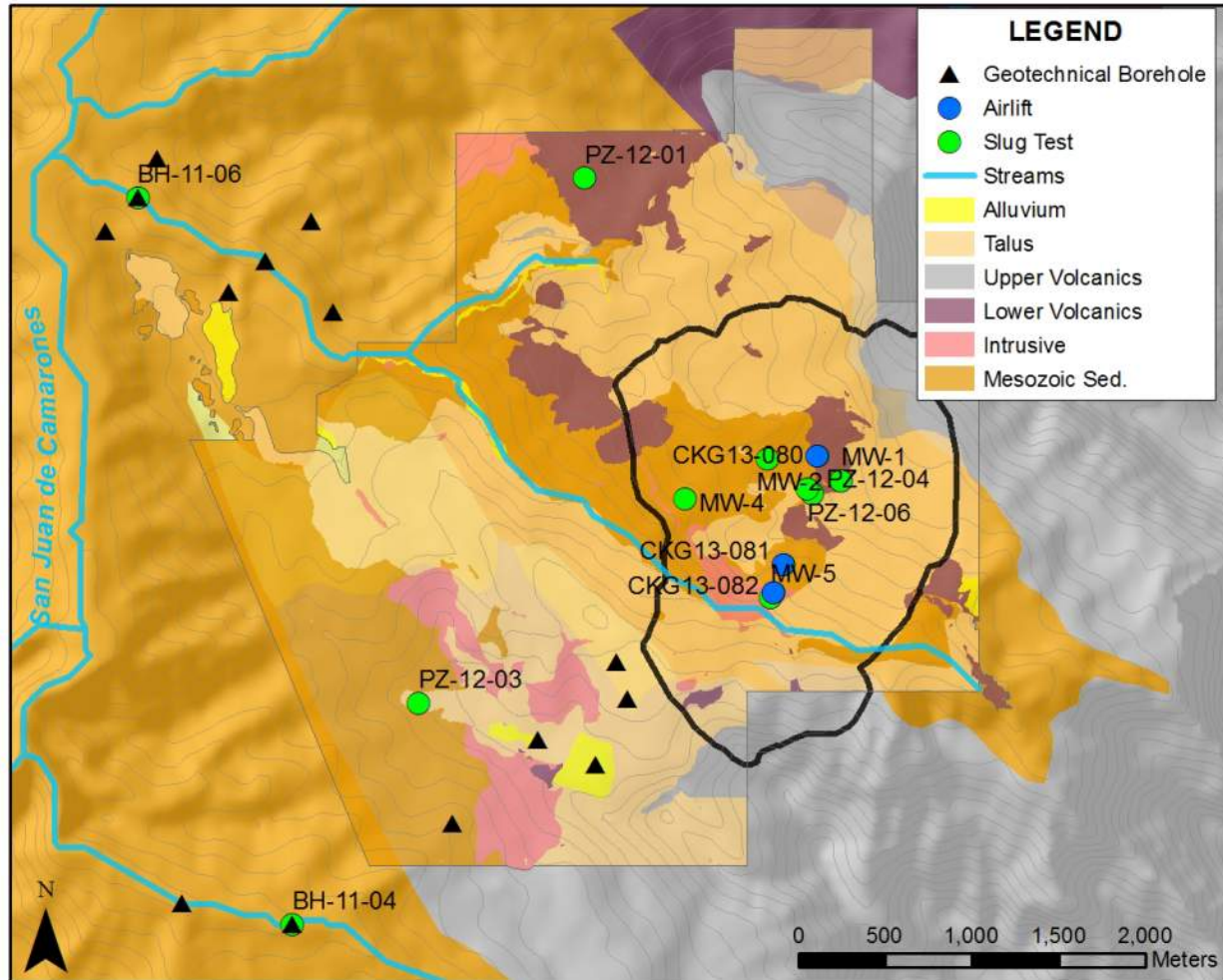

Figure 20-7: Borehole Locations of Airlift and Slug Tests

Hydraulic conductivities were estimated from the results from the air lift and slug tests noted above, ranging from 2.5×10^{-5} to 1.5×10^{-1} m/day with a geometric mean of 5.9×10^{-4} . These values fall within the range typically associated with indurated sandstone. Additional hydrogeologic testing in the pit area, including packer testing and a long-term pumping tests are suggested for the Metates site.

A groundwater flow model was constructed to evaluate the impact of the Metates pit on the groundwater regime, estimate required dewatering flows, and simulate post-mining groundwater conditions in relation to the pit lake. The finite difference code MODFLOW-SURFACT Version 4.0 (SURFACT) was selected for the groundwater model. SURFACT is a peer-reviewed code based on the popular MODFLOW code and is accepted by the scientific community to accurately solve the variably saturated groundwater flow equation for conditions similar to those in the present study. The model domain (Hatch, 2016) is bordered by the San Juan de Camarones River drainage from a point approximately 12 km downstream of the Metates Site and a small portion of the San Gregorio drainage to include the potential extent of drawdown impacts and to maintain the continuity in the deeper regional groundwater flow system (Figure 20-8). The model grid covers an area 27.45 km x 35.05 km and is oriented N16°E, approximately parallel to the San Juan de Camarones River and orthogonal to contributing drainages near the mine.

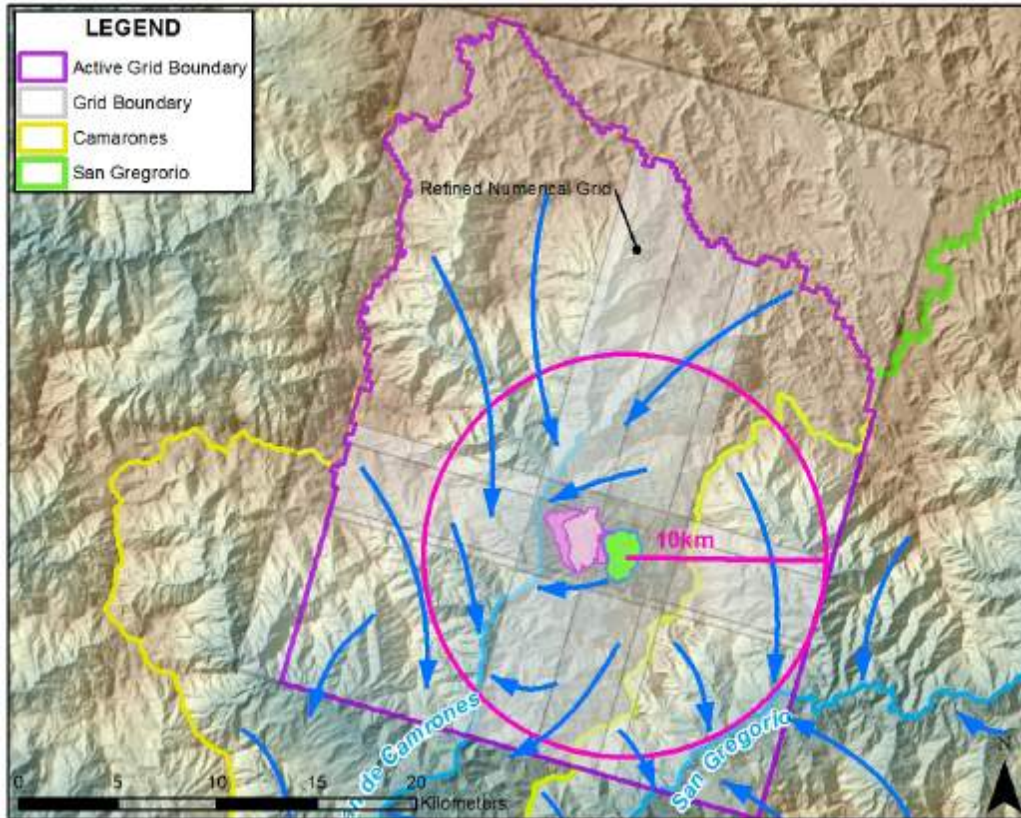

Figure 20-8: Numerical Model Active Grid Area

Future studies will include the development of two models to simulate:

- Dewatering of the pit during operation and
- Development of a pit lake following the end of mining.

The dewatering model will be designed to simulate the progressive dewatering as the pit is excavated. The pit lake development model will be designed to simulate the interaction of groundwater with the pit as well as any surface waters that may be re-directed into the pit during the closure period. The inputs required are the mass-balance budget of the pit and the pit lake elevation.

20.13 RECLAMATION AND CLOSURE

Reclamation and closure plans for the Metates site are presented in Section 18. The costs associated with reclamation and closure are presented in Section 21.

21 CAPITAL AND OPERATING COSTS

21.1 CAPITAL COST

The consolidated mine and process capital cost is shown in Table 21-1. The PEA-level total estimate for the mine, crushing plant, oxidation and heap leach pads, Merrill-Crowe plant and supporting ancillary facilities is US\$359.2 million, including contingency and working spares.

Table 21-1: Consolidated Mine and Process Facility Initial Capital Costs, US\$000

	Cost
Metates Site	
Mining Equipment & Mine Development	\$18,713
Crushing & Conveying	\$36,104
Ponds & Pads	\$28,404
Reagent/Regeneration System	\$11,677
Merrill-Crowe & Refinery	\$9,124
Subtotal	\$104,022
Infrastructure	
General Site/Earthworks/Access Roads	\$106,069
Electric Power	\$7,851
Water Supply	\$7,380
Ancillaries & Buildings	\$11,121
Subtotal	\$132,421
Freight, Taxes & Duties	\$4,060
Total Direct Field Cost	\$240,503
Indirects-EPCM, Commissioning & Spares	\$32,047
Total On Site Constructed Cost	\$272,550
Contingency	\$63,459
First Fills	\$6,000
Owner's Cost	\$17,200
Total Capital Cost	\$359,209

21.1.1 Currency

The estimate is expressed in second-quarter 2021 United States dollars. No provision has been included to offset future escalation. No funds have been allocated in the estimate to offset potential currency fluctuations.

21.1.2 Scope

The capital cost estimate for the project addresses the engineering, procurement, construction, and start-up of a 15,000 tpd operation, which will recover gold and silver from mineralized material mined and processed in Durango State, Mexico.

The scope of work for M3 includes the oxidation and recovery circuit from primary crushing to doré production, and ancillary facilities including mine truck shops and warehouses, and fuel and lubrication facilities.

Also included in the capital cost estimate are the costs for the Metates mine, water diversion channels, power supply infrastructure starting from existing CFE power lines, access road improvement, water supply and delivery, solution pumping and piping.

M3 is responsible for the assembly of the overall capital-cost estimate with supporting data provided by others for the key areas noted in Table 21-2 below.

Table 21-2: Capital Cost Estimate Areas and Responsible Parties

Area	Responsible Party
Metates Mine	IMC
Rainwater Diversion Channel	M3
Water Supply, Delivery and Storage	M3
Power Supply Infrastructure	M3
Process Facilities	M3
Indirect Costs	All
Owner's Cost	Chesapeake
Contingency	M3 & IMC

21.1.3 Metates Mine Capital Basis

IMC has developed an estimate of mine capital costs based on contract mining. The estimate is not based on contractor quotes due to the preliminary nature of this study. The estimate was developed as follows:

- First, an estimate of mine capital and operating costs was developed for an owner operated mine fleet from first principles for the life of mine plan presented in Section 16.
- Contractor mobilization and demobilization costs were estimated.
- An allowance was added for equipment that will be purchased by the owner.
- Mine development cost, i.e., the cost of mining during the preproduction period, by the contractor, is included.

Table 21-3 shows the life of mine capital cost for contract mining. Overall, these costs amount to a total of US\$ 31.3 million over the life. The table shows the buildup of the estimate as follows:

- Mobilization – Major equipment buildup is at the beginning of preproduction, Year 1, Year 2, and Year 4. The purchase price for this equipment is estimated at US\$ 93.8 million for the owner operation case. Contractor mobilization was estimated at 8% of this amount, or US\$ 7.50 million over these years. This is an allowance of about 5% of the equipment price for equipment transportation and an additional 3% for logistics, hiring of personnel, procuring supplies/equipment, etc.
- Demobilization – This is estimated at 5% of the US\$ 93.8 million estimate for major equipment mobilized during preproduction through Year 4, or US\$ 4.69 million at the end of Year 31.
- Owner Equipment – An allowance for owner equipment is estimated at 10% of the mine major equipment purchases for the owner operation case at the beginning of preproduction and at the beginning of Year 1. This amounts to US\$ 4.45 million for these years. This equipment includes pickup trucks and other vehicles, engineering equipment such as GPS, surveying equipment, computers, software licenses, etc.
- Mine Development – US\$ 14.62 million is the estimated operating cost to mine 5.16 Mt of material during the preproduction period by the contractor. The cost is developed in the Mine Operating Cost section of this report and includes direct operating cost, considerations of equipment depreciation costs, and contractor profit.

The capital cost for the following facilities is included in M3's estimate:

- The mine shop and warehouse
- Fuel and lubricant storage facilities
- Storage facilities for blasting agents and high explosives
- Office facilities

Table 21-3: Mine Capital Cost – Contract Mining

MINE CAPITAL COSTS:		Units	PP	Year 1	Year 2	Year 3	Year 4	Year 5	Year 30	Year 31	TOTAL
Contractor Mobilization (% of Major)	8.0%	(\$x1000)	1,818	1,742	1,568	0	2,375	0	0	0	7,502
Contractor Demobilization (% of Major)	5.0%	(\$x1000)	0	0	0	0	0	0	0	4,689	4,689
Owner Equipment (% of Major)	10.0%	(\$x1000)	2,273	2,177	0	0	0	0	0	0	4,449
Mine Development		(\$x1000)	14,622	0	0	0	0	0	0	0	14,622
Mine Infrastructure		(\$x1000)									0
TOTAL MINE CAPITAL COST		(\$x1000)	18,713	3,918	1,568	0	2,375	0	0	4,689	31,263

21.1.4 Metates Process Plant Capital Basis

The direct cost for the Metates site facilities is US\$221.8 million as shown in Table 21-4. The estimate is based on vendor quotes for major equipment, M3 historical data, material estimates for steel and concrete based on general arrangement drawings. The cost of the offsite electrical substation and all the project overland transmission lines is also included.

Table 21-4: Summary of Direct Costs for the Mine and Processing Facilities

Description	Amount, US\$000
General Site	106,069,397
Primary Crushing	10,334,324
Fine Crushing	18,118,163
Mixing & Conveying	7,651,788
Oxidation Pad & Ponds	15,014,126
Soda Ash Regeneration & Make Up	2,877,559
Leach Pad & Ponds	13,390,251
Merrill Crowe	7,856,149
Refinery	1,268,280
Water Systems	6,316,647
Fresh Water System	1,063,445
Power Supply	7,851,410
Reagents	8,799,559
Ancillaries & Buildings	11,120,789
Freight	3,248,250
Taxes & Duties	812,063
Subtotal	221,792,200

21.1.5 Water Supply

The Metates water supply system capital cost is estimated by a de-escalation of the relevant portions of the previous studies design. The overall water supply capital costs are a combination of pipeline costs and pumping/storage infrastructure.

Metates water supply will be a combination of groundwater and surface water. The pipelines expected to be required as part of the supply system are:

- Supply line from pit rim to process ponds
- Supply line from surface water reservoir to process ponds

Engineering/Administration, installation and pumping/piping equipment are included in this cost estimate, which is reflected in Table 21-4 as 'Water Systems'.

21.1.6 Sustaining Capital, Reclamation and Closure

The sustaining capital costs for the mine and process facilities are summarized in Table 21-5, totaling \$46.375 M.

Table 21-5: Sustaining Capital Schedule

Sustaining Capital, US\$000											
	LOM	Year 1	Year 2	Year 4	Year 5	Year 10	Year 15	Year 20	Year 25	Year 30	Year 31
Total	\$46,375	\$3,918	\$1,568	\$2,375	\$1,393	\$1,253	\$3,670	\$6,984	\$8,540	\$11,985	\$4,689

At the end of operations, reclamation and closure costs are estimated to be US\$133.5 M. This is slightly offset by a credit for the salvage value of US\$3.438 M, which is equivalent to 5% of equipment cost.

21.2 OPERATING COST

21.2.1 Operating Cost Summary

The life-of-mine operating cost for the Metates facilities is estimated to be US\$18.29 per tonne of mineralized material as summarized in Table 21-6. This cost includes the Metates mining operations, heap oxidation operation, leaching and metal recovery operation, and supporting facilities (laboratory, G&A, community development, etc.). The life of mine operating cost is shown below by cost component, where silver revenue is treated as an operating credit.

Table 21-6: Life of Mine Operating Cost Summary

Mineralized Material Tonnes (Processed kt)	166,091	
Total Tonnes – Moved (kt)	533,998	
	LOM Average	
Metates Facilities	Annual Cost (US\$000)	US\$/mineralized material tonne
Mining	\$40,239	\$7.51
Heaps and Merrill-Crowe Operations	\$43,141	\$8.05
Site Support	\$7,531	\$1.41
Incremental Employee Profit Sharing	\$6,994	\$1.32
Total Operating Cost	\$97,905	\$18.29
Doré Treatment Charges	\$924	\$0.17
Royalties	\$7,786	\$1.45
By-Product Credit (Silver)	(\$44,203)	(\$8.25)
Total Cash Cost	\$62,413	\$11.66
Sustaining Capital, Reclamation & Closure	\$5,691	\$1.06
AISC	\$68,104	\$12.72

21.2.2 Scope

The following cost centers were developed by M3, based on prevailing costs for labor, fuel, power, commodities, and consumables. The life-of-mine processing costs shown above include costs for each of the cost centers:

- Metates Site
 - Mining Operations
 - Crushing
 - Mixing & Conveying
 - Oxidation Pad & Ponds
 - Alkaline Regeneration & Make-Up
 - Leach Pad & Ponds
 - Merrill Crowe
 - Refinery
 - Water Systems
 - Power Supply
 - Reagents
 - Ancillaries & Buildings

Labor costs were derived from a staffing plan and based on Mexican labor rates. The labor rates include all applicable social security benefits and payroll taxes.

Electrical power will be provided by connection to an existing CFE power line. The delivered cost of electricity is US\$ 0.10 per kWh. Power consumption was based on the equipment list connected kW, discounted for operating time and the operating load.

Reagent consumption was based on a combination of preliminary metallurgical tests and projections based on data from similar operations where applicable. Reagent consumption is discussed further in Section 17. Reagent pricing was estimated from budgetary quotes from vendors, which were then expanded upon by M3 to consider cost of delivery in greater detail.

An allowance was made to cover the cost of maintenance parts and outside repairs based on 5% of the direct cost of capital equipment.

Annual allowances for supplies and services, which include lubricants, diesel fuel, safety items, outside services and tools, and miscellaneous supplies were considered for each cost center.

M3 is responsible for the assembly of the overall operations cost estimated with supporting data provided by others for the key areas noted in Table 21-7 below.

Table 21-7: Operating Cost Estimate Areas and Responsible Parties

Area	Responsible Party
Metates Mine	IMC
All Other Areas	M3

21.2.3 Metates Mine Operating Cost

IMC prepared an estimate of mine operating costs based on contract mining. The estimate is not based on contractor quotes due to the preliminary nature of this estimate. The estimate was developed as follows:

- First, an estimate of operating costs was developed from first principles for the life of mine plan presented in Section 16 assuming an owner-operated mine fleet.
- An estimate of equipment depreciation costs incurred by the contractor was developed.

- An estimate of contractor profit was also included.

Table 21-8 shows the estimated operating costs for contractor operation. Total mine operating cost during commercial production is \$US1.25 billion. This amounts to US\$2.195 per total tonne mined and US\$7.51 per leach tonne. Note there is also a line on the table for the mine development cost of US\$14.6 million that was reported with mine capital costs. The table shows the buildup of the estimate as follows:

- Owner Operating Cost – Mine operating costs for the owner operation case was estimated at US\$ 1.04 billion over the project life, including the preproduction period.
- Mine Technical Services and Supplies – The cost for engineering, geology, surveying and grade control personnel, including an allowance for supplies, is also deducted. It is an owner cost and not subject to contractor markup. This amounts to US\$26.9 million over the project life.
- Fuel and Blasting – It is also assumed the owner is providing diesel fuel, so it is not a contractor cost. Blasting is also assumed to be a separate contract with the vendor of the blasting agents or another party. These costs amount to US\$ 392.7 million and US\$ 106.5 million respectively over the mine life.
- Contractor Direct Operating Cost – Owner operating cost, less the deductions described above, is an estimate of direct contract mining costs. This is estimated at US\$ 513.9 million over the mine life, about 50% of the total operating cost.
- Contractor Equipment Depreciation Charge – The contract mining cost will include significant charges for equipment depreciation. It is not certain how a specific contractor will calculate this cost. Life of mine the depreciation charge is estimated at US\$ 141.0 million, including a 10% allowance for small equipment. This is comparable to the US\$ 148.3 million life of mine equipment capital costs for the owner operation case. Equipment depreciation is 13.6% of the direct operating cost estimate of US\$ 1.04 billion.

Table 21-9 shows the estimate of depreciation costs per shift for each equipment type. The equipment replacement cost is the new, delivered price used for the owner operation case. The column labeled Equipment Life shows the life of the equipment, in metered hours, that was used for equipment replacement calculations. 10,000 hours was deducted from each piece of equipment to obtain the adjusted (contractor) equipment life. This is an accelerated depreciation or a risk premium for the contractor. Assuming a 10% salvage value for equipment, and straight line depreciation, the equipment depreciation per metered hour and per shift are shown. This is based on 10.75 metered hours per shift.

- Contractor Overhead/Profit – 15% of Contractor Direct Operating Cost. Note the 15% is not applied to the depreciation allowance.
- Mine Technical Services and Supplies, Fuel, and Blasting Costs – These owner costs are added back to obtain the total mine operation cost. A line item for Owner Mine Manager is also shown. That person will be the liaison with the contractor manager.

There are some specific risks related to contract mining. There is risk that the contractor may need financial assistance from the owner either in terms of cash, or loan guarantees, to procure some equipment, increasing the capital cost.

The operating cost estimate is based on assumed prices for commodities such as fuel, explosives, parts, tires, etc. that are subject to wide variations depending on market conditions. The estimate is based on the following prices for key commodities:

- Diesel fuel delivered to the site for \$US 0.977/liter,
- ANFO delivered to the site for US\$ 0.555/kg,

- Emulsion delivered to the site for US\$ 0.720/kg.

Table 21-10 shows the mining cost estimate by cost centers for the commercial production period. Total cost, cost per total tonne, and cost per tonne processed (leach tonnes) are shown.

Table 21-8: Mine Operating Cost – Contract Mining

MINE OPERATING COST:	Units	PP	Year 1	Year 2	Year 3	Year 4	Year 5	Year 6	Year 7	Year 8	Year 9	Year 10	Year 11	Year 12	Year 13	Year 14	Year 15	Year 16
Owner Operating Cost	(\$x1000)	12,113	27,320	36,768	39,043	52,886	52,242	45,081	45,195	49,372	52,675	53,025	47,035	45,948	48,980	52,357	58,072	64,615
Less Technical Services and Supplies	(\$x1000)	632	1,092	1,092	1,092	1,092	1,092	1,092	1,092	1,092	1,092	1,092	1,092	1,092	1,092	1,092	1,092	1,092
Less Fuel (Owner Supplied)	(\$x1000)	3,446	9,763	13,746	14,360	20,726	20,377	16,798	16,842	18,902	20,525	20,740	17,748	17,195	18,680	20,345	21,820	25,258
Less Blasting (Separate Contract)	(\$x1000)	1,184	3,112	3,946	4,839	5,634	5,670	5,819	5,853	5,830	5,835	5,745	5,830	5,873	5,875	5,871	5,881	5,884
Contractor Direct Cost	(\$x1000)	6,850	13,354	17,985	18,752	25,434	25,104	21,372	21,409	23,548	25,223	25,448	22,364	21,789	23,334	25,049	29,280	32,381
Contractor Depreciation Charge	(\$x1000)	1,394	3,681	5,090	5,286	7,274	7,166	6,053	6,067	6,709	7,214	7,280	6,349	6,177	6,640	7,159	7,618	8,689
Contractor Overhead/Profit @ 15.0%	(\$x1000)	1,028	2,003	2,698	2,813	3,815	3,766	3,206	3,211	3,532	3,783	3,817	3,355	3,268	3,500	3,757	4,392	4,857
Total Contract Mining Cost	(\$x1000)	9,271	19,038	25,772	26,851	36,523	36,035	30,631	30,687	33,789	36,220	36,546	32,068	31,235	33,474	35,965	41,290	45,927
Add Back Technical Services and Supplies	(\$x1000)	632	1,092	1,092	1,092	1,092	1,092	1,092	1,092	1,092	1,092	1,092	1,092	1,092	1,092	1,092	1,092	1,092
Add Back Fuel	(\$x1000)	3,446	9,763	13,746	14,360	20,726	20,377	16,798	16,842	18,902	20,525	20,740	17,748	17,195	18,680	20,345	21,820	25,258
Add Back Blasting	(\$x1000)	1,184	3,112	3,946	4,839	5,634	5,670	5,819	5,853	5,830	5,835	5,745	5,830	5,873	5,875	5,871	5,881	5,884
Add Owner Mine Manager	(\$x1000)	88	120	120	120	120	120	120	120	120	120	120	120	120	120	120	120	120
TOTAL OPERATING COST - Commercial	(\$x1000)	0	33,124	44,675	47,261	64,094	63,292	54,460	54,593	59,732	63,792	64,242	56,858	55,513	59,240	63,392	70,201	78,281
TOTAL OPERATING COST - Development	(\$x1000)	14,622	0	0	0	0	0	0	0	0	0	0	0	0	0	0	0	0
Total Material	(kt)	0	15,510	20,000	24,999	30,000	30,000	29,999	29,999	29,999	29,999	30,000	29,998	30,000	29,999	29,999	29,999	29,999
Plant Feed	(kt)	0	5,000	5,475	5,475	5,475	5,475	5,475	5,475	5,475	5,475	5,475	5,475	5,475	5,475	5,475	5,474	5,475
Cost Per Total Tonne	(US\$/t)	0.000	2.136	2.234	1.891	2.136	2.110	1.815	1.820	1.991	2.126	2.141	1.895	1.850	1.975	2.113	2.340	2.609
Cost Per Plant Tonne	(US\$/t)	0.000	6.625	8.160	8.632	11.707	11.560	9.947	9.971	10.910	11.652	11.734	10.385	10.139	10.820	11.578	12.824	14.298

MINE OPERATING COST:	Units	Year 17	Year 18	Year 19	Year 20	Year 21	Year 22	Year 23	Year 24	Year 25	Year 26	Year 27	Year 28	Year 29	Year 30	Year 31	TOTAL
Owner Operating Cost	(\$x1000)	64,137	23,186	16,589	14,147	14,905	16,286	17,909	17,852	11,498	11,498	11,285	11,285	11,008	10,798	4,866	1,039,976
Less Technical Services and Supplies	(\$x1000)	1,092	712	712	712	712	712	712	459	459	459	459	459	459	459	230	26,902
Less Fuel (Owner Supplied)	(\$x1000)	25,011	8,108	5,704	4,658	5,007	5,635	6,370	6,983	4,492	4,492	4,382	4,382	4,239	4,151	1,811	392,698
Less Blasting (Separate Contract)	(\$x1000)	5,884	2,377	1,800	1,530	1,566	1,659	1,771	1,218	0	0	0	0	0	0	0	106,488
Contractor Direct Cost	(\$x1000)	32,150	11,990	8,373	7,247	7,620	8,279	9,056	9,192	6,547	6,547	6,444	6,444	6,310	6,189	2,825	513,888
Contractor Depreciation Charge	(\$x1000)	8,612	2,916	2,164	1,836	1,945	2,141	2,371	2,494	1,701	1,701	1,667	1,667	1,622	1,595	716	140,994
Contractor Overhead/Profit @ 15.0%	(\$x1000)	4,822	1,798	1,256	1,087	1,143	1,242	1,358	1,379	982	982	967	967	947	928	424	77,083
Total Contract Mining Cost	(\$x1000)	45,585	16,704	11,793	10,170	10,708	11,663	12,785	13,065	9,230	9,230	9,077	9,077	8,879	8,712	3,965	731,965
Add Back Technical Services and Supplies	(\$x1000)	1,092	712	712	712	712	712	712	459	459	459	459	459	459	459	230	26,902
Add Back Fuel	(\$x1000)	25,011	8,108	5,704	4,658	5,007	5,635	6,370	6,983	4,492	4,492	4,382	4,382	4,239	4,151	1,811	392,698
Add Back Blasting	(\$x1000)	5,884	2,377	1,800	1,530	1,566	1,659	1,771	1,218	0	0	0	0	0	0	0	106,488
Add Owner Mine Manager	(\$x1000)	120	120	120	120	120	120	120	120	120	120	120	120	120	120	60	3,735
TOTAL OPERATING COST - Commercial	(\$x1000)	77,691	28,021	20,129	17,190	18,112	19,789	21,758	21,845	14,301	14,301	14,038	14,038	13,696	13,441	6,066	1,247,166
TOTAL OPERATING COST - Development	(\$x1000)	0	0	0	0	0	0	0	0	0	0	0	0	0	0	0	14,622
Total Material	(kt)	29,999	10,681	7,502	6,012	6,211	6,727	7,341	7,933	5,475	5,475	5,475	5,475	5,475	5,475	2,317	568,072
Plant Feed	(kt)	5,475	5,475	5,475	5,475	5,475	5,475	5,475	5,475	5,475	5,475	5,475	5,475	5,475	5,475	2,317	166,091
Cost Per Total Tonne	(US\$/t)	2.590	2.623	2.683	2.859	2.916	2.942	2.964	2.754	2.612	2.6120	2.564	2.564	2.502	2.455	2.618	2.195
Cost Per Plant Tonne	(US\$/t)	14.190	5.118	3.676	3.140	3.308	3.614	3.974	3.990	2.612	2.612	2.564	2.564	2.502	2.455	2.618	7.509

Table 21-9: Equipment Depreciation per Shift

Equipment Type	Replac. Cost (US\$)	Equip Life (hrs)	Contractor Life (hrs)	Depreciation (Notes 1,2)	
				Per Hr (\$/hr)	Per Shift (\$/shift)
Caterpillar MD6250 Drill	1,961,538	60,000	50,000	35.31	379.56
Caterpillar 6030FS Hyd Shovel	4,132,767	80,000	70,000	53.14	571.21
Caterpillar 992K Wheel Loader	1,999,062	60,000	50,000	35.98	386.82
Caterpillar 777G Truck	1,658,960	90,000	80,000	18.66	200.63
Caterpillar D10T2 Track Dozer	1,567,974	55,000	45,000	31.36	337.11
Caterpillar D9T Track Dozer	1,142,262	55,000	45,000	22.85	245.59
Caterpillar 834K Wheel Dozer	1,354,743	50,000	40,000	30.48	327.68
Caterpillar 16M3 Motor Grader	1,349,610	50,000	40,000	30.37	326.44
Water Truck - 18,000 gal	1,842,665	100,000	90,000	18.43	198.09
Caterpillar 345FL Excavator	523,883	45,000	35,000	13.47	144.82
Sandvik DI560 DTH Drill	806,450	45,000	35,000	20.74	222.93

Note 1. Depreciation assumes 10% salvage value, i.e. hourly depreciation = 0.9 x cost / life
 Note 2. Assumes 10.75 metered hours per shift

Table 21-10: Mining Costs by Cost Center

Cost Center	Total Cost (US\$)	Cost Per Total Tonne (US\$/t)	Cost Per Leach Tonne (US\$/t)	% of Total
Drilling	60,811	0.107	0.366	4.9%
Blasting	105,304	0.185	0.634	8.4%
Loading	132,187	0.233	0.796	10.6%
Hauling	388,834	0.684	2.341	31.2%
Roads and Dumps	200,873	0.354	1.209	16.1%
Mine Services	62,827	0.111	0.378	5.0%
Mine Administration	80,674	0.142	0.486	6.5%
Equipment Depreciation	139,600	0.246	0.841	11.2%
Contractor Profit	76,056	0.134	0.458	6.1%
Total Operating Cost	1,247,166	2.195	7.509	100.0%
Total and Leach Ktonnes		568,072	166,091	

21.2.4 Metates Process Plant Operating Costs

Table 21-11 is a summary of the operating costs for the Metates plant facilities. The bases for the M3 estimates have been discussed earlier in this section.

Table 21-11: Summary of Operating Costs for Various Facilities

Plant Area	LOM Cost (US\$ 000)	Cost per Tonne of Mineralized Material
Crushing & Conveying	\$100,664	\$0.61
Alkaline Storage & Unloading, Heap Oxidation and Heap Leach	\$1,110,964	\$6.69
Merrill Crowe & Refinery	\$59,920	\$0.36
Ancillary Services	\$65,818	\$0.39
Total Metates Processing Operations	\$1,337,366	\$8.05

21.3 SUPPORT FACILITIES

Table 21-12 summarizes the cost of operating the support facilities for the entire operation, including the assay and metallurgical lab and all General & Administrative costs, including senior staff salaries. These costs are contained within the total processing costs in Table 21-11.

Table 21-12: Summary of Operating Costs for Support Facilities

Support Facilities	LOM Cost (US\$000)	Cost/t Mineralized Material
Laboratory	\$19,772	\$0.12
General and Administrative	\$213,693	\$1.29
Total Support Facilities	\$233,465	\$1.41

22 ECONOMIC ANALYSIS

22.1 INTRODUCTION

The Metates Project economic analysis uses a discounted cash flow approach to determine the net present value (NPV), payback period (time in years to recapture the initial capital investment), and the internal rate of return (IRR). Annual cash flow projections are estimated over the life of the mine based on estimates of capital expenditures, production costs, and sales revenue. Revenues are based on the production of gold and silver. The estimates of capital expenditures and site production costs are developed specifically for this project and have been presented in the previous section.

Only measured and indicated mineral resource is considered for this study. Inferred intrusive mineral resource in the pit is only half a million tonnes and is treated as waste. The results of this PEA are preliminary in nature. There is no certainty that the results of this PEA will be realized. Mineral resources that are not mineral reserves do not have demonstrated economic viability.

22.2 MINE PRODUCTION STATISTICS

Mine production is reported as mineralized material and waste from the mining operation. The annual production figures were obtained from the mine plan as discussed earlier in this report.

The life of mine mineralized material quantities and mineralized material grades are presented in the Table 22-1.

Table 22-1: Life of Mine Mineralized Material Quantities and Mineralized Material Grade

	Tonnage, kt	Au, g/t	Ag, g/t
Mineralized Material	166,091	0.756	15.709
Waste	367,907		
Total Material Mined	533,998		

22.3 PLANT PRODUCTIONS STATISTICS

The estimated life of mine metal production over the 31 years of operation is presented in Table 22-2.

Table 22-2: Life of Mine Metal Production

	Life of Mine
Gold, troy ounces (to doré)	2,825,000
Silver, troy ounces (to doré)	62,286,000

22.4 MARKETING RETURN FACTORS

Applicable smelter treatment and refining charges and other marketing terms are discussed in Section 19.

22.5 CAPITAL EXPENSES

The base case financial indicators have been determined using the assumption of 100% equity financing of the initial capital. The total capital estimate for the project is US\$359 million. The total capital expenditure includes US\$17 million for owner's costs, and contingencies of approximately US\$64 million. Table 22-3 is a summary of estimated capital costs for the Metates Project.

Table 22-3: Capital Cost Summary (US\$000)

Area	Total
Metates Site	
Mining Equipment & Mine Development	\$18,713
Crushing & Conveying	\$36,104
Ponds & Pads	\$28,404
Reagent/Regeneration System	\$11,677
Merrill-Crowe & Refinery	\$9,124
Subtotal	\$104,022
Infrastructure	
General Site/Earthworks/Access Roads	\$106,069
Electric Power	\$7,851
Water Supply	\$7,380
Ancillaries & Buildings	\$11,121
Subtotal	\$132,421
Freight, Taxes & Duties	\$4,060
Total Direct Field Cost	\$240,503
Indirects-EPCM, Commissioning & Spares	\$32,047
Total On Site Constructed Cost	\$272,550
Contingency	\$63,459
First Fills	\$6,000
Owner's Cost	\$17,200
Total Capital Cost	\$359,209

22.5.1 Owner's Costs

Owner's costs were estimated by Chesapeake and total US\$17.2 million. Major areas in the owner's costs include an allowance for development drilling, owner's insurance, early staffing, surface occupation lease payments, construction or upgrades of access roads, relocation of the village of Vascogil, miscellaneous land payments, environmental costs, and change of land use payments to SEMARNAT.

22.5.2 Working Capital

A cash reserve of six months is added to the capital cost to cover operating expenses before revenue is initially generated. The first six months of operating cost will come from that cash reserve which allows for the revenue generation delay of oxidizing and leaching mineralized material. In the financial model, a 15-day delay of revenue recognition until receipt of cash has been used for accounts receivables. A delay of payment for accounts payable of 30 days is also incorporated into the financial model.

22.5.3 Sustaining Capital

Sustaining capital is scheduled periodically over the operating life of the mine for heap leach pad expansion at the Metates mine. Sustaining capital for the mining operations at Metates is quite low as mining operations are by an outside contractor. Table 22-4 shows the cash flow for the sustaining capital, which totals US\$46.375 million.

Table 22-4: Sustaining Capital Summary

Sustaining Capital, Reclamation & Closure, US\$000											
	LOM	Year 1	Year 2	Year 4	Year 5	Year 10	Year 15	Year 20	Year 25	Year 30	Year 31
Total	\$46,375	\$3,918	\$1,568	\$2,375	\$1,393	\$1,253	\$3,670	\$6,984	\$8,540	\$11,985	\$4,689

22.6 CASH OPERATING COST

The cash operating cost for the life of mine is US\$686/oz of gold on a by-product basis. Shown below in Table 22-5 are the operating metrics for LOM, including a break-out for Years 2-5.

Table 22-5: Cash Cost Summary

Operating Period	Years 2-5	Years 1-31
	Active Mining	Life of Mine
Material Mined		
Total Material Mined From Pit (ktonnes)	105,000	533,998
Material To Process (ktonnes)	21,900	166,091
Low Grade Material To Stockpile (ktonnes)	10,098	38,797
Waste Rock (ktonnes)	73,002	367,907
Strip Ratio	2.28	2.22
Average Processing Rate (ktonnes/year)	5,475	5,358
Average Processed Grades		
Gold (g/t)	0.832	0.756
Silver (g/t)	25.94	15.71
Cumulative Metal Production		
Gold (doré) koz.	410	2,825
Silver (doré) koz.	13,700	62,916
Average Annual Production		
Gold (koz.)	102.5	91.1
Silver (koz.)	3,425	2,030
Cash Cost (US\$/Au Oz) Byproduct Basis	\$535.84	\$685.98

The AISC (“all-in sustaining cost”) on a LOM basis is US\$ 748 per ounce and is based on the by-product LOM cash cost of US\$ 686 per ounce and adding an allowance for sustaining capital of US\$ 16.42 per ounce, reclamation, closure costs and a salvage value of US\$ 46.06 per ounce.

22.7 RECLAMATION AND CLOSURE COST AND SALVAGE VALUE

Reclamation and closure cost applied concurrent to operations and after the end of operations are estimated at US\$133,500,000 for the Metates facilities. Reclamation costs are realized in the final year of pit operation as part of sustaining capital costs.

The salvage value of the equipment is estimated at 5% of the equipment cost (US\$3.4 million) and is applied as a credit at the end of operations.

22.8 DEPRECIATION

The cash flow analysis employs a straight-line depreciation method, applied over a period of 10 years for initial capital, and over a period of 8 years for sustaining capital.

22.9 TAXATION

M3 applies a 3% tariff for equipment and materials imported into Mexico under the program *Industria Manufacturera, Maquiladora y de Servicios de Exportación* (IMMEX), which is the Promotion of the Manufacturing, Maquila and Export Service Industry decree. This tariff is included as part of the equipment capital cost.

The value added tax (IVA) in Mexico is 16%. All operating expenses and capital costs are subject to this tax. Reimbursements for the tax occur through the Secretaría de Hacienda and usually take about 45 days. No allowance for IVA has been made in the financial model since this is essentially an “in-out” cost.

A 30% federal income tax is applied to net income after depreciation costs. There are no applicable state or local taxes.

22.10 MINING ROYALTIES

Production costs include three mining-related royalties or special taxes:

- A 7.5% special tax has been applied to include income from mining activities and which is paid to the Federal Government. The tax is calculated on a basis of earnings before interest, income taxes, depreciation and amortization (EBITDA).
- A 0.5% royalty has been applied on revenue from precious metals which is paid to the Federal Government.
- A 0.5% royalty is applicable to all metal production and is owed to Wheaton Precious Metals.

All of these taxes are assumed to be deductible against income before the calculation of corporate income tax.

22.11 FINANCIAL RESULTS

The financial results were developed for four different metal price assumptions (base case, low case, high case and a spot price); these assumptions were provided to M3 by Chesapeake. The financial results are presented in Table 22-6.

Table 22-6: Financial Results Summary

Financial Results Summary				
Metal Price Assumptions	Low Case	Base Case	High Case	Spot
Gold (US\$/oz.)	\$1,360.00	\$1,600.00	\$1,840.00	\$1,786.00
Silver (US\$/oz.)	\$19.00	\$22.00	\$25.00	\$26.00
Pre-Tax Economic Indicators				
NPV @ 5% (\$000)	\$717,107	\$1,141,527	\$1,565,778	\$1,525,001
IRR %	25.3	35.4	45.1	45.2
Payback (yrs)	3.4	2.5	2.0	2.0
After-Tax Economic Indicators				
NPV @ 5% (\$000)	\$407,274	\$682,214	\$956,465	\$930,095
IRR %	17.7	24.4	30.7	30.6
Payback (yrs)	5.2	3.7	3.0	2.9

22.12 SENSITIVITY ANALYSIS

Sensitivity analyses were performed for the project using metal prices, operating cost, capital cost, and metal recovery as variables. The economic indicators tested against these variables are the NPV, IRR, and payback period. Base case metal prices are assumed as the starting point, and the initial capital of US\$359.2 million.

The capital cost, operating cost and the metal price factors have the greatest impact on the economic indicators. Metal recoveries should be optimized with operating cost in mind during the operation of the plant, as inflating reagent consumption in attempt to increase recoveries can be counter-productive, depending on metal prices. Figure 22-1 and Figure 22-2 show the sensitivities for each of the factors tested. The project’s economic indicators are notably stable across all sensitivity categories considered.

Table 22-7: Sensitivity of NPV @ 5%, Pre-Tax

Sensitivity of NPV @ 5%, US\$000					
% Change	Metal Prices	Operating Cost	Initial Capital	Gold Recovery	Silver Recovery
15%	\$1,576	\$936	\$1,093	\$1,467	\$1,248
10%	\$1,431	\$1,005	\$1,109	\$1,359	\$1,212
0%	\$1,142	\$1,142	\$1,142	\$1,142	\$1,142
-10%	\$852	\$1,278	\$1,174	\$924	\$1,071
-15%	\$707	\$1,347	\$1,191	\$816	\$1,036

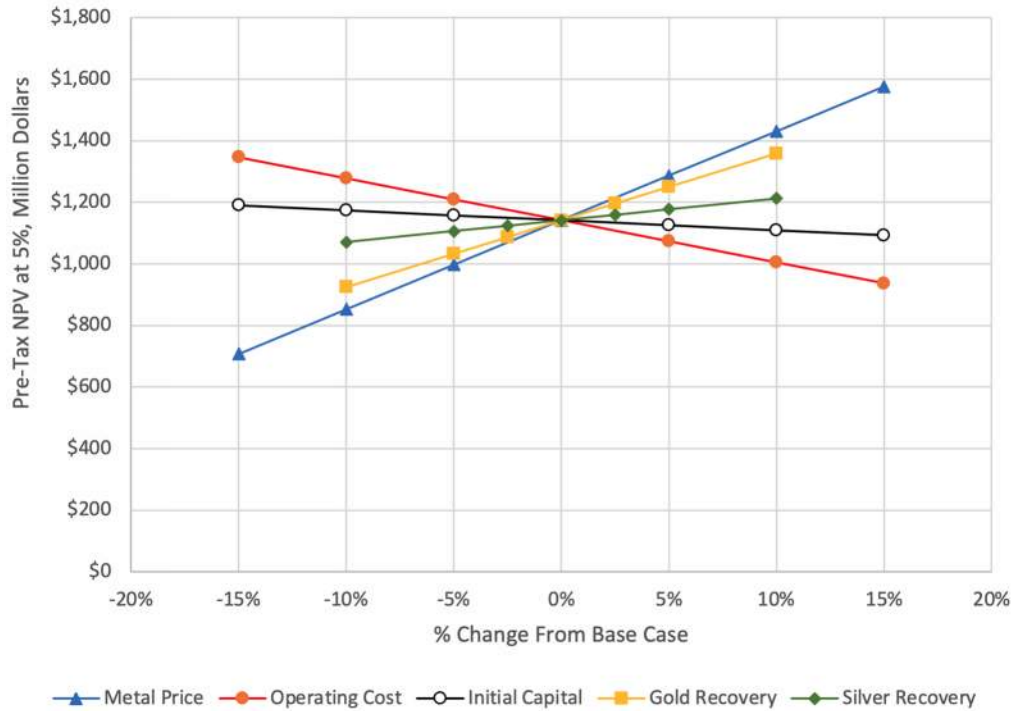

Figure 22-1: Sensitivity of NPV 5% to Metal Prices, Operating Cost, Capital Cost, Overall Recovery

Table 22-8: Sensitivity of IRR, Pre-Tax

Sensitivity of IRR, %					
% Change	Metal Prices	Operating Cost	Initial Capital	Gold Recovery	Silver Recovery
15%	46%	31%	30%	41%	40%
10%	42%	33%	32%	39%	38%
0%	35%	35%	35%	35%	35%
-10%	29%	38%	40%	31%	33%
-15%	25%	40%	42%	29%	31%

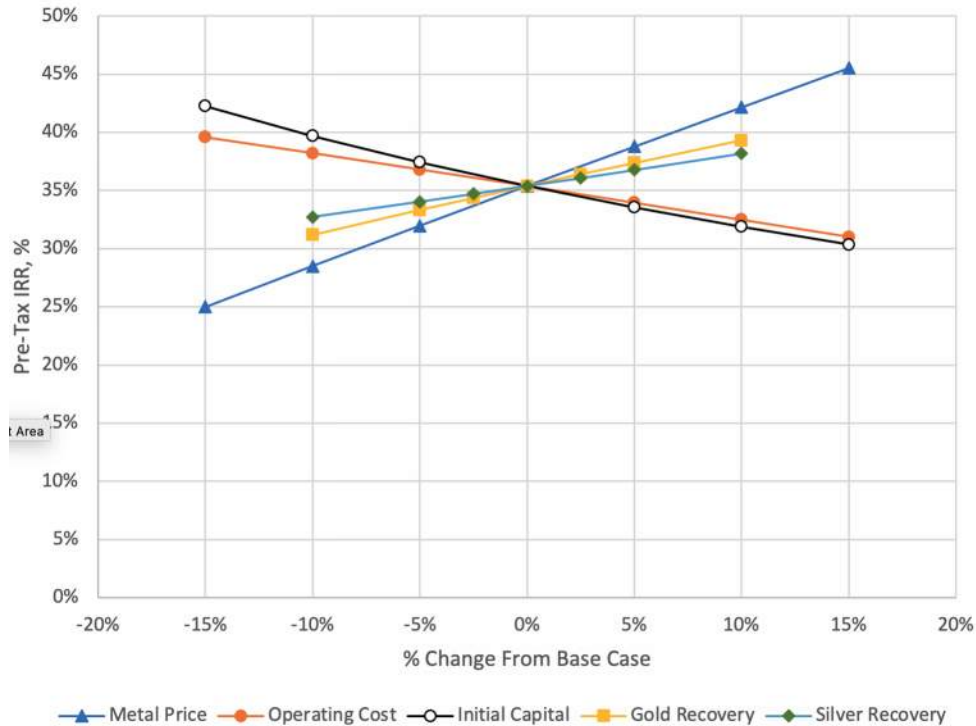

Figure 22-2: Sensitivity of IRR to Metal Prices, Operating Cost, Capital Cost, Overall Recovery

22.13 LEVERAGED-CASE

For a leveraged case assuming initial capital is 60% debt financed at an annual interest rate of 7%, an upfront fee of 3%, and a seven-year term post commencement of commercial production with a balloon payment of 30% of the principal at maturity, the following after-tax leveraged case financial parameters were calculated:

- US\$681 million NPV at 5.0% discount rate;
- 41.2% IRR;
- 2.2-year initial capital payback.

22.14 COMPARISON BETWEEN THE 2016 PFS AND THIS PEA

With this PEA, the Metates Project offers two alternate development options for the deposit: the 2016 PFS case and this PEA case. The 2016 PFS features a rapid production ramp up with higher initial capital but a higher metal

production volume. This PEA has significantly lower initial capital, superior investment return indicators and a very different approach to the treatment of the mineralization at Metates. The reduced plant throughput lends flexibility to operations in terms of power and water supply, greatly reducing the scope of infrastructure work required for plant development.

Operating cash costs per ounce also increased in this PEA as a result of a change to a processing methodology which has relatively higher reagent consumptions to oxidize and recover gold and silver at a reduced recovery, but with the benefit of over US\$3 billion in total capital reduction. The 2016 PFS realizes zinc by-product credits which are not included in the process plan for this PEA.

It is recommended by M3 that Chesapeake advance the Metates Project toward the completion of an NI 43-101-compliant pre-feasibility study (PFS) with the new processing plan as presented in this PEA as the preferred development scenario.

23 ADJACENT PROPERTIES

The Ciénega Mine is a 4,000 tpd operation located some 22 km from the Metates deposit, 15 km north-northwest of the village of San Juan de Camarones. This is a vein-type (5–8 m width) deposit hosted in Tertiary volcanic rocks, producing gold and silver doré as well as lead and zinc concentrates. This underground type of operation was first placed into production in 1992 by Industrias Peñoles, and is now operated by an affiliated company, Fresnillo plc., a publicly traded company. For 2020, published proven and probable reserves totaled 343,000 ounces gold grading 2.36 g/t and 33.7 Moz silver grading 232 g/t. The mine also hosts significant resources.

Americas Silver Corp. (Americas), a public company, operates several underground-type mines approximately 70 km west-southwest of Metates and just east of the town of Cosalá. The Nuestra Señora Mine is currently operating at a rate of about 1,600 tpd, and produces precious metal bearing lead, zinc, and copper concentrates. Americas also controls four other development or past producing stage projects close to Cosalá; La Estrella, La Verde, San Rafael and El Cajon, which host significant silver and base metal resources. More recently, Americas placed the San Rafael mine in operation.

There are no other significant exploration, development or operating projects or mines are known to exist close to the Metates site.

24 OTHER RELEVANT DATA AND INFORMATION

24.1 PROJECT EXECUTION PLAN

This project execution plan is at a preliminary economic estimate level. It will require additional detail at the pre-feasibility stage, feasibility stage and at project start.

The Metates gold-silver deposit is among the largest undeveloped mining projects in the world, located in the mountains of northwestern Durango, Mexico in an area with little infrastructure. The low total connected load will allow the plant to be powered through connection to nearby (20 km) existing power lines which are part of the existing CFE grid. Water to the mine will be supplied from a combination of ground and surface sources. Both utilities will need to be developed early on in the project to support construction/commissioning activities.

24.1.1 Summary

An engineering company should be retained to advance the project in process design and cost estimates. Further refinement of the process plan will ease the determination of the optimal processing plan and highlight opportunities to reduce project risk and enhance project economics. The pre-feasibility work can begin as soon as the on-going comprehensive metallurgical test program is completed; increasingly accurate cost and recovery data will yield more precise engineering specifications and a reduced project contingency.

24.1.2 Future Technical Reports

Many items of the preliminary economic assessment study will require additional testing, review, engineering, and action before they can be incorporated into a preliminary feasibility study or a feasibility study (definitive or bankable), including:

- Additional foundation (geotechnical) drilling for structures, equipment, dams, and road design.
- Additional environmental studies to enable permitting to begin and be completed.
- Additional metallurgical testing, including testing of the complete process beginning with heap leach oxidation and extensive variability testing.
- Further development of engineering drawings and specifications as required to produce material takeoffs and detailed cost estimations.
- More detailed capital and operating costs and financial estimates.
- Additional work on owner's cost items, including acquisition of surface rights, water rights, etc.
- Budgetary purchasing bid calls and proposals from three prequalified vendors for all major equipment items.

24.1.3 Access Roads

Improvements to the road between the existing municipalities and the Metates mine site will need to be made to enable delivery of major equipment to site. The road from Santiago Papasquiaro is expected to be the primary route to site; improvements to the roads between Cosalá and the Metates site should also be considered for flexibility of access.

24.1.4 Water Storage

Permitting, engineering investigation, and land acquisition for the Metates (San Juan de Camarones) water storage dam must advance. This dam is to be roller-compacted concrete type. More site-specific geotechnical testing and

planning needs to be performed. Design must be closely coordinated with permitting activities and water supply arrangements.

24.1.5 Permitting

M3 Mexicana has been assisting Chesapeake with onsite investigations. While permitting is more straightforward in Mexico than in most countries, it is recommended that the owner appoint a Mexican national as permitting director. A permitting matrix and plan should be submitted with the feasibility study. World Bank standards should be followed.

25 INTERPRETATION AND CONCLUSIONS

25.1 PROPERTY DESCRIPTION AND HISTORY

The Metates mine site is located in a mountainous area of northwest Durango State, Mexico at about 1,000 m elevation. Exploration at Metates dates back to the early 1980's by a Frisco/BP joint venture. In the 1990's, a Cambior/Luismin joint venture completed an extensive amount of drilling, metallurgical and other technical studies. Thereafter, low metal prices amongst other factors led to Metates sitting idle for almost ten years until it was acquired (100%) by Chesapeake in 2007. Since acquisition, Chesapeake has conducted significant drilling that resulted in a succession of new resource estimates. During this period, several industry leading consultants have also performed comprehensive metallurgical, geotechnical, engineering, and environmental studies. The extensive drill data, test work and related studies have been compiled and summarized in a series of PEA and PFS technical reports.

This PEA evaluates a lower mineralized material throughput development scenario and supersedes the PFS titled "Metates Gold-Silver Project NI 43-101 Technical Report Updated Preliminary Feasibility Study" dated April 29, 2016 (2016 PFS).

25.2 MINERAL RESOURCE

This PEA uses a slightly revised resource model from the 2016 PFS and has a measured and indicated mineral resource for the Metates deposit that amounts to 1.30 billion tonnes at 0.47 g/t gold and 12.9 g/t silver for 19.8 Moz of contained gold and 542.0 Moz of contained silver. Inferred mineral resource is an additional 62.2 Mt at 0.32 g/t gold and 9.0 g/t silver for 640,000 ounces contained gold and 18.0 Moz of contained silver. The revised estimate is based on updated prices, costs, and recovery parameters. The deposit is hosted in Cretaceous age sedimentary rocks which have been intruded by an altered intrusive sill or dome. The geologic setting and metallurgy have similarities to other deposits in Mexico such as Cerro de San Pedro in San Luis Potosi State, El Castillo in Durango State as well as the large Pueblo Viejo deposit in the Dominican Republic. The Metates deposit is one of the largest undeveloped gold and silver deposits in the Americas.

25.3 MINING

The mining method for Metates is conventional bulk open pit mining. Based on the mining plan developed for this study, the commercial life of the project is 31 years after a brief preproduction period. Total mineral resource processed is 166.1 Mt at 0.756 g/t gold and 15.71 g/t silver. This amounts to 4.04 Moz of contained gold and 83.9 Moz of contained silver. Only measured and indicated mineral resource is considered for this study. Inferred intrusive mineral resource in the pit is only half a million tonnes and is treated as waste. However, this PEA is preliminary in nature and there is no guarantee that the results of this study will be realized or that the mineral resources will be converted to mineral reserves.

This mine plan is based on a production rate of 15,000 tpd (5,475 ktpy). An expansion to 30,000 tpd could be undertaken in Years 3 – 5, funded completely by internally generated cash flow; the current study and mine plan assume that this expansion does not occur.

The Metates mineral resource is broadly divided into intrusive hosted and sedimentary hosted rock types. The mine plan for this study only considered the intrusive hosted mineralization as potential plant feed. There will be a stockpile for sedimentary hosted resource that is not considered plant feed for this PEA. There will also be a low-grade stockpile facility to store marginal grade intrusive material for processing at the end of the commercial pit operations (Years 24 – 31). There are also separate waste storage facilities to segregate NAG (non-acid generating) waste and PAG (potentially acid generating) waste.

25.4 METALLURGY

Extensive metallurgical testing in support of the oxidation and leach process is ongoing. Kemetco Research Inc (Richmond, BC) is managing the test program, including sighter tests, baseline tests, column tests, and agitated oxidation test, all of which will be conducted on recent drill cores samples. The testing completed thus far has supported cost and recovery modeling in this report, and further discussion of technical results and assumptions can be found in Section 13 of this report. Crushed and agglomerated mineralized material will be fed to an oxidation pad where it will spend an average of 120 days, before being rehandled and placed on the permanent leach pad. The leach pad material will undergo cyanidation and Merrill-Crowe recovery of gold and silver as doré. Acidic solutions generated by the heap oxidation process will be neutralized in-situ by alkaline reagents introduced in the oxidation solution and recycle ponds.

25.4.1 Oxidation Tests

The various oxidation tests on the Metates mineralized material are intended to corroborate the relationship between oxidation and gold and silver recovery from previous work. Additionally, they will establish the alkaline reagent consumption, kinetics, and water/air requirements to achieve economic oxidation in a heap leach environment.

Initial tests were used to support the cost and recovery assumptions in this study; long running column tests will develop the understanding of an optimized oxidation process, specifically regarding gold and silver recovery points of diminishing return for heap leach crushed mineralized material.

25.5 METAL RECOVERY

25.5.1 Gold and Silver Recovery

The design for gold and silver recovery is a conventional, large scale, Merrill-Crowe precipitation plant. Overall life of mine gold recovery from mineralized material to doré is estimated at 70%, with silver recovery at 75%.

25.6 WASTE MANAGEMENT, RECLAMATION AND CLOSURE

The waste management strategy for the Metates site incorporates disparate waste dumps for PAG and NAG across three separate dump sites. This approach allows for management and control of any potential acid drainage, as well as the eventual re-utilization of NAG to cover PAG material near the end of mine life as part of an overall reclamation and closure plan. Sedimentary material with considerable grade will be segregated from other PAG material in case an opportunity to economically process the material for recovery is realized during the mine life. The waste management strategy for the 325 million tonnes of PAG generated in this mine plan should be developed in more detail in future studies. One advantage of the current layout of NAG and PAG waste rock dumps as well as the oxidation and heap leach facilities is that all are contained within the Arroyo San Nicholas drainage which will simplify capture and management of any potential acid drainage.

The reclamation and closure plan for Metates also assumes a long-term, stable pit lake will be maintained at an equilibrium level by a combination of runoff from adjacent areas and natural evaporative losses from the water surface. Further development of the pit lake management plan should be included in future studies; a reasonable execution plan was developed in the 2016 PFS which can be used as a basis.

25.7 PROJECT FINANCIALS

The PEA demonstrates strong project economics across a broad range of analyzed sensitivities. As expected, the project has high leverage to metal prices, but still maintains attractive financial indicators even when considering a 15% reduction in gold and silver prices from the base case (US\$ 1,600 gold, US\$ 22 silver).

METATES SULPHIDE HEAP LEACH PROJECT - PHASE 1
FORM 43-101F1 TECHNICAL REPORT

At the base case, the PEA demonstrates that Metates will generate a pre-tax NPV of US\$ 1.14 billion at a 5% discount rate with an IRR of 35.40%. The LOM cash operating cost is US\$ 695 per ounce with an AISC cost of US\$ 748 per ounce. The project is expected to generate US\$ 2.77 billion in gross pre-tax income (EBITDA) at base case metal prices. A summary of the pre-tax sensitivity analysis is presented in Table 25-1 and Table 25-2.

Table 25-1: Sensitivity of Pre-Tax NPV @ 5%, US\$000

Sensitivity of NPV @ 5%, US\$000					
% Change	Metal Prices	Operating Cost	Initial Capital	Gold Recovery	Silver Recovery
15%	\$1,576	\$936	\$1,093	\$1,467	\$1,248
10%	\$1,431	\$1,005	\$1,109	\$1,359	\$1,212
0%	\$1,142	\$1,142	\$1,142	\$1,142	\$1,142
-10%	\$852	\$1,278	\$1,174	\$924	\$1,071
-15%	\$707	\$1,347	\$1,191	\$816	\$1,036

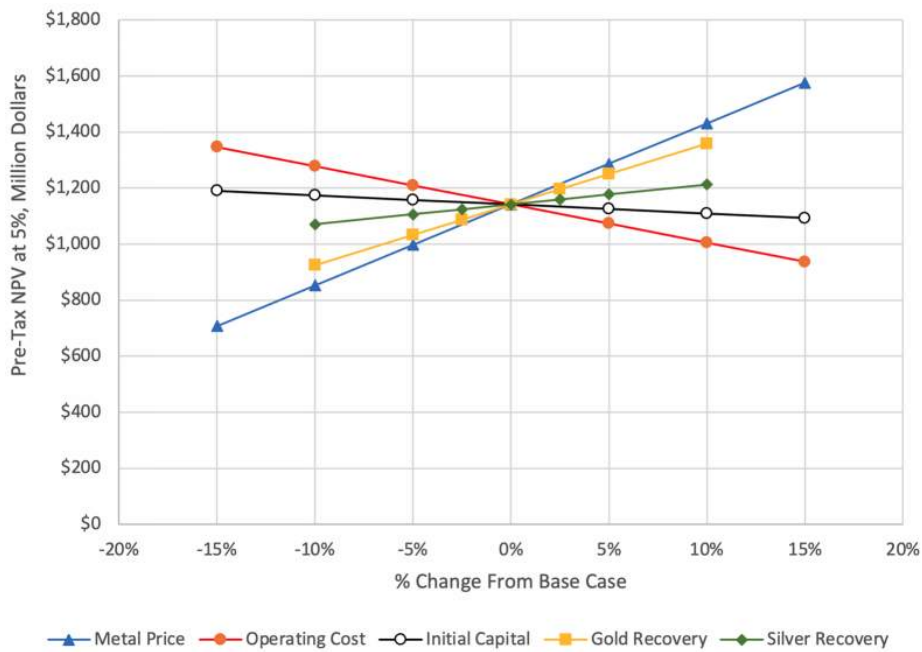

Figure 25-1: Sensitivity of NPV 5% to Metal Prices, Operating Cost, Capital Cost, Overall Recovery

Table 25-2: Sensitivity of Pre-Tax IRR, %

Sensitivity of IRR, %					
% Change	Metal Prices	Operating Cost	Initial Capital	Gold Recovery	Silver Recovery
15%	46%	31%	30%	41%	40%
10%	42%	33%	32%	39%	38%
0%	35%	35%	35%	35%	35%
-10%	29%	38%	40%	31%	33%
-15%	25%	40%	42%	29%	31%

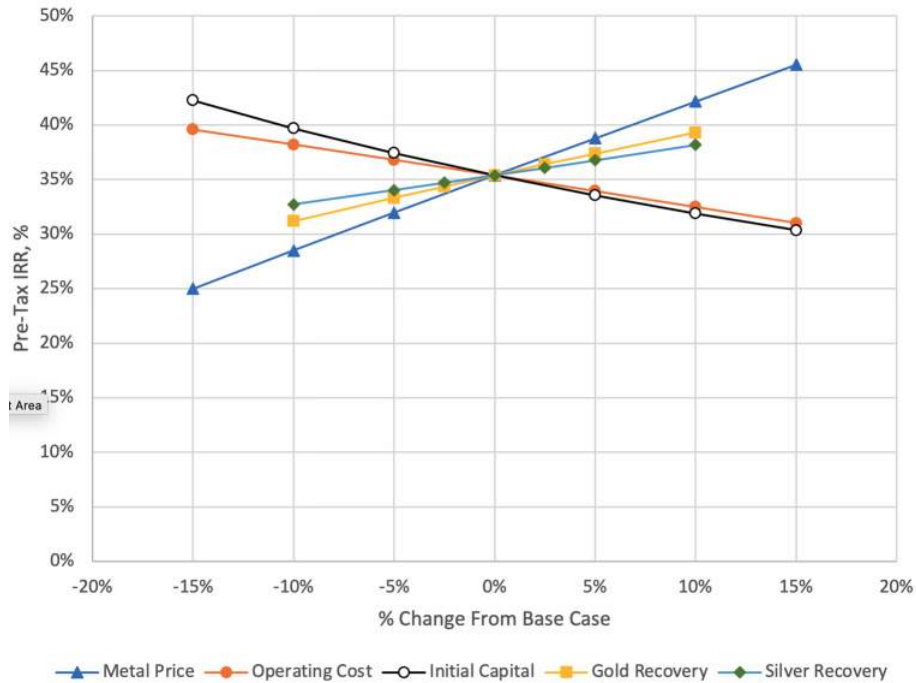

Figure 25-2: Sensitivity of IRR to Metal Prices, Operating Cost, Capital Cost and Metal Recoveries

The effect of operating cost and recovery fluctuations are of the same magnitude, but with an inverse effect. Additional recovery can be achieved by increasing levels of oxidation for placed material; alkaline reagents are consumed to drive the oxidation process and neutralize acid that is produced. It is likely that any increase in recovery will be won with an increase in operating cost, as such a target for extent of oxidation will need to be optimized to account for economics.

Overall, sensitivity analysis indicates that this is a robust project that can withstand 15% increases/decreases in the key cash flow components as follows:

- If mining and processing operating costs were to increase 15% from those currently estimated, the project would remain viable by interpolation of the sensitivities shown in Table 25-1 and Table 25-2.
- If initial capital costs were to increase 15% from those currently estimated, the project would remain viable by interpolation of the sensitivities shown in Table 25-1 and Table 25-2.

- If metal prices were to decrease 15% from those used to establish the base case, the project would remain viable by interpolation of the sensitivities shown in Table 25-1 and Table 25-2.

25.8 CONCLUSIONS

Metates is an undeveloped world-class mineral deposit with minimal obstacles in the way of becoming a producing mine. Few deposits of this scale have development options with capital costs on the order of US\$359 million, while carrying a pre-tax NPV of over US\$1 billion. Compared to the two previous PFS studies, this PEA has substantially lower initial capital, lower project execution risk and stronger financial indicators. The short payback period and early positive cash flow allow for flexibility in Metates future development, including the potential to capitalize on the low grade and sedimentary hosted mineralization and further exploration of the limits of the mineralization. It is recommended by M3 that Chesapeake advance the Metates Project toward the completion of an NI 43-101-compliant pre-feasibility study once conclusive results from the metallurgical testing program are available.

26 RECOMMENDATIONS

M3 recommends that Chesapeake advance the Metates Project toward the completion of a pre-feasibility study once conclusive results are available from the ongoing metallurgical testing program. The preferred process option is heap oxidation of crushed mineralized material, followed by cyanide extraction on a dedicated heap leach pad, with gold and silver recovered as doré completed through a Merrill-Crowe plant. The discussion below is not meant to be totally comprehensive and focuses mostly on the physical testing and studies that are recommended prior to the completion of the pre-feasibility study.

The estimated cost for the studies as listed below is US\$3,455,000. These additional funds will cover pre-feasibility level design work, engineering and costing for the primary engineering firm as well as any sub-consultants. The drilling program, test work program and environmental monitoring program is also included in this cost.

26.1 EXPLORATION, GEOLOGY AND DRILLING

IMC recommends an in-fill drilling program focused on the area of the early years of mining activity to provide more detailed information to support estimates for gold, silver and sulphur grades. It is estimated that about 15 holes and 6,000 meters of drilling will be required. The estimated direct cost (drilling, assaying, and supervision) of this entire program is approximately US\$1.5 million. It is likely that the drill core from these holes will be used to supply further metallurgical work.

As a result of the additional drilling, the geologic interpretation and resource block model will need to be updated.

26.2 RESOURCE MODEL UPDATE

If the project is advanced to a pre-feasibility study, IMC recommends the resource block model be updated to incorporate the results of the five holes drilled during 2021. This would include updating the geologic interpretation, the grade estimates, and the resource classification. Consideration will be given to an infill drill program focusing on the intrusive-hosted mineralization based on the higher than modeled grades noted in the recent core drilling program. The update would also incorporate the results of the in-fill drill program discussed above.

This updated model would be used to develop an updated mineral resource, mining plan, and mineral reserve as part of the PFS. The cost for this work is estimated at US\$45,000.

26.3 METALLURGY

The following metallurgical test programs are planned to take the Metates Project to the pre-feasibility study level.

26.3.1 Oxidation and Recovery Testing

Additional oxidation testing will be required to test for oxidation kinetics, reagent consumption and metal recoveries. Variability testing will also be required to establish metal recoveries and oxidation rates across different “whole ore” types, feed grades, etc. During the course of this program, optimization should be sought between the extent of oxidation and gold equivalent recovery. The ideal operating point will shift according to metal prices, but a well understood relationship between oxidation and recovery will simplify process modeling and decisions during operations.

Lab scale column tests and bottle rolls are currently ongoing at Kemetco. These tests will establish a baseline level of understanding among process variables for the two major “whole ore” host rock types within the Metates deposit. The cost for this test program, with an allowance for additional unplanned tests, is US\$1.1 million.

Recent drilling will provide sufficient core samples that will enable a comprehensive test program to evaluate oxidation time, reagent consumption and gold and silver recoveries to an extent and accuracy which will support a pre-feasibility level study.

If additional drilling information and/or core is required for various needs going forward, M3 recommends that drilling be performed in the area of planned material extraction for Years 1 – 5 in the current mine plan to increase confidence in the grades that will be processed early in the mine life.

26.3.2 Preg-Borrowing Materials and Future Outlook

The sedimentary material, mentioned throughout the report as a stockpiled material, holds potential as economically viable material if metallurgical processes are designed to realize its potential. Methods using autoclaves, CIL or RIL have been studied in the past and shown to be effective in improving the recovery of gold and silver from the sedimentary mineralization. While this potentially preg-borrowing material may not be suitable for conventional cyanide heap leach recovery, testwork is planned to further investigate possible treatment scenarios to realize its potential. Over the 31-year span of this processing plan, one of these treatment scenarios may provide a path for the sedimentary material to be reclaimed and processed. This is the driver for separating the mineralized sedimentary material stockpile from the other PAG material dump in the current site design plan.

26.4 PROCESS FACILITIES

26.4.1 Geotechnical Investigations

Additional geotechnical investigations are recommended in areas where facilities have been located in this study but for which little if any geotechnical work has been performed. An example would be the proposed dam location along the Rio San Juan de Camarones. Additional geotechnical work, consisting mostly of test borings and hydrogeological testing, should be performed to assess the characteristics of the valley slopes and areas of cut and fill that will form the side walls of the valley-fill heap leach pad and the oxidation pad, respectively. The recommendation for these additional investigations is made under the assumption that the process plan is being advanced to a pre-feasibility level.

26.4.2 Materials Take Offs

The grading of the Metates site is a significant undertaking that requires a large amount of earthworks to provide flat, accessible terrain for all process facilities. Currently, the civil works estimate is based on a rough grading plan called for by the design level and does not distinguish between areas of soil or rock. Moving forward, a closer balance between cut and fill will be developed which should significantly reduce the earthworks cost to the Project and the overall initial capital. Material take offs for concrete and steel will be developed as the building sizes change and the size and number of tanks are modified. A focus of any study going forward should be the refinement of the site civil design; material costs for all other aspects of the plant design are small by comparison.

26.4.3 Capital and Operating Cost Estimates

To bring the Project to pre-feasibility level, the following studies are recommended:

- Additional vendor quotations.
- Better oxidation operating cost estimate, with a more narrowly defined alkaline reagent regeneration plan.
- Better earthworks estimate based on balancing the cut and fill used to support the oxidation pad, Merrill-Crowe plant and solution collection ponds, etc.

- Deeper investigation into alkaline reagent sources, to establish best pricing and potentially increase process flexibility by expanding reagent options.
- Further development of site access plan to simplify mobilization/demobilization and potentially reduce reagent/supply delivery costs.
- Optimization of the phasing/timing of the construction of various project facilities to minimize initial capital including the construction and lining of the valley fill heap leach pad, pond locations, conveyor configurations, solution pumping requirements, etc. might allow for a more efficient use and timing of capital expenditures and lower operating costs.
- Reduce water infrastructure size/cost due to consumption reduction compared to previous studies where designs originated.

26.5 INFRASTRUCTURE

26.5.1 Access Roads

For access roads, it is recommended that a geotechnical map be prepared of the road corridor to support better routing and estimation of construction costs. Evaluation of options for stream and river crossings (bridge, at grade/vado crossing, culvert) is warranted to optimize costs. It is also recommended that Chesapeake move forward with securing rights of way from state governments. The cost estimates for the access roads would be improved by defined execution plans and updated construction estimates from qualified companies.

26.5.2 Electric Power

Advance design of electrical power supply connection and distribution across the site. Electric power is expected to be supplied by a connection to an existing CFE line approximately 20 kilometers away from the planned Metates process facility. An agreement for use of power will need to be discussed with Comisión Federal de Electricidad (CFE) including further verification of the lines' available capacity against other planned uses for the line that may not have appeared in M3's initial investigation. Further refinement of the capital equipment necessary to connect to existing lines should be investigated to improve the estimate to a pre-feasibility level.

26.5.3 Water

Develop a comprehensive site-wide water balance that integrates the various process facilities with their water demands, rainfall/runoff relationships, contact versus non-contact waters, etc. Water sourcing demands and availability from both groundwater and surface water sources on a seasonal and life of mine basis needs to be estimated.

On a preliminary basis, it is recommended that Chesapeake take steps to better define the transfer of surface water rights within the San Lorenzo basin and have preliminary discussions with existing water rights holders. If possible, secure options to transfer up to 3,000 m³/day of water rights. Advancement of groundwater systems design is also required to move the study to a pre-feasibility level.

26.6 OTHER

26.6.1 Preferred Development Option

The PEA describes a low capital, heap oxidation and leach project, that is stable when considering a wide range of sensitivities. It is recommended that this PEA be further developed to the pre-feasibility study level to improve the accuracy of estimates, optimize the site plan and corroborate technical/metallurgical assertions with a completed test program. The cost to complete engineering at a pre-feasibility level, including mine planning, is US\$560,000.

Further investigations should be conducted on the potential of a throughput expansion for the crushing plant and processing facilities. During the PEA, an expansion to 30,000 tpd was considered but ultimately excluded from the report as further design work was needed on placement of the expanded facilities. It is probable that an expansion to 30,000 tpd between years 3 and 5 would benefit project economics through improved capital efficiency while still providing a long mine life. As this development option is explored in greater detail, a throughput optimization analysis should be conducted to maximize economic indicators while maintaining the robust characteristics of the operating plan.

26.6.2 Environmental Baseline

Sampling of surface and groundwater at the Metates site should be continued. Existing information on various types of waste rock should be included in an updated reclamation and closure plan that is specific to the currently favored plan for project development. This plan will evaluate the opportunity for concurrent reclamation and the mitigation and possible treatment of any acid drainage. Estimated cost of the environmental monitoring required is US\$250,000 over two years.

26.6.3 Stakeholder Engagement

Define a comprehensive strategy for the engagement of local, regional and national stakeholders. This will include continued discussions with state government officials (Durango), a more formal program of discussions with the local communities and ejidos that may be impacted by the Metates Project, and a series of informational meetings/exchanges to help manage expectations and provide a basis of fact as the project moves forward. Discussions with government officials, lobbyists, and trade groups operating on a national level will also be needed. Evaluate the social and economic impacts to the communities surrounding the project that might accompany project development. Study the availability of skilled and unskilled labor for project construction and operation.

Initiate discussions with the national environmental and permitting agency SEMARNAT to better define the most effective permitting strategies and data requirements for permit applications. Identify any unique circumstances or issues related to permitting that might impact the timing and approval of project operating permits.

27 REFERENCES

- AES Mexico. 2015. 500 MW Power Supply to Metates Mining Project Proposal. Mexico City, Mexico. May 2015.
- Air Products and Chemicals, Inc. 2015. Updated Budgetary Quotation for Supply of Oxygen. Allentown, PA. February 2015.
- ALS Metallurgy. 2013. Pressure Oxidation Testwork, Report A14615. Perth, Australia. Jan 2013.
- AMTEL. 2020. Department of Gold & Silver in Pyrite Float Concentrate From Metates Ore, 41 pages.
- ANSTO Minerals. 2013a. Zinc Batch Leach Tests for the Metates Project. Sydney, Australia. December 2013.
- ANSTO Minerals. 2013b. Iron & Zinc Precipitation Mini Plants. Sydney, Australia. December 2013.
- Ausenco. 2013a. Metates Gold Project – Co-disposal Base Case, Mine Pit Diversion and Water Supply Facilities. Englewood, CO. September 2013.
- Ausenco. 2013b. Ranchito TSF Base Case. Englewood, CO. February 2013.
- Ausenco. 2015a. Metates Gold Project PFS –Metates Site Design Report. Englewood, CO. July 2015.
- Ausenco. 2015b. Metates Gold Project PFS –El Paso Site Design Report. Englewood, CO. June 2015.
- Ausenco. 2015c. Metates and El Paso Tailings – Dry Stacking Design Report. Englewood, CO. June 2015.
- Ausenco. 2015d. Arroyo San Juan de Camarones Water Supply Dam and Reservoir.
- Brierley Associates, LLC. 2012a. El Paso Tunnel: Conceptual Design and Engineer's Opinion of Probable Costs. Littleton, CO. October 2012.
- Call & Nicholas, Inc. 2009. Proposed Slope Angles for Expanded Metates Pit Plan, Power Point Presentation. Tucson, AZ. December 2009.
- Call & Nicholas, Inc. 2012. Prefeasibility Slope Angles for Metates Deposit. Tucson, AZ. December 2012.
- Contract Support Services. 2011a. Proposed Grinding Circuit Simulation Study. Red Bluff, CA. October 2011.
- Contract Support Services. 2011b. Letter Report of Results – Chesapeake Gold Metates Proposed Grinding Simulation Study. Red Bluffs, CA. December 2011.
- Core Resources. 2009. Preliminary Metates Gold-Silver Project Albion Process Study. Turner, D. Brisbane, Australia. December 2009.
- Core Metallurgy Pty Ltd. 2020. Chesapeake Gold Corp. Metates Project – Albion Amenableity Testwork Report; H. Liang, Core Metallurgy Report No. 1260A-001. September 2020.
- Cytec Canada, Inc. 2012. Letter Report on Flotation Tests to Improve Recovery on Metates Ore. Bruce, T. Toronto, Canada. February 2012.
- Elemental Engineering. 2015. Phase 1 & 2 Mass and Energy Balance, Metates Project. J. Vagenas. Sydney, Australia. November 2015.

METATES SULPHIDE HEAP LEACH PROJECT - PHASE 1
FORM 43-101F1 TECHNICAL REPORT

- EMG, LLC. 2015a. Metates & El Paso Mining Mobile Equipment Evaluation with EMG Data Base. Phoenix, AZ. 11 February 2015.
- EMG, LLC. 2015b. Metates & El Paso Mining Mobile Equipment Evaluation with EMG Data Base. Phoenix, AZ. 17 December 2015.
- FLSmidth Dawson Metallurgical Laboratories. 2009. Final Report on Confirming Test Work on Samples CH-A and CH-I from the Metates Project, Project No. P-4082. Bennett, P. Salt Lake City, UT. August 2009.
- FLSmidth. 2020. Pretreatment Of the Metates Refractory Gold Concentrate by FLSmidth Rapid Oxidative Leach. Project No. 9232509443. Diane Taggart. Midvale, Utah. August 24, 2020.
- Golder Associates. 1997. Results of Static and Kinetic Testing of Waste Rock Samples, Metates Project, Mexico.
- Golder Associates. 2009. Results of Geochemical Characterization for the 2007–2008 Drilling Samples—Technical Memorandum. Waples, J. November 2009.
- Hatch, Inc. 2015. Ground Water Model Report, Rev. B. Fort Collins, CO. October 2015.
- Hatch, Inc. 2016. Pit Lake Model Report. Fort Collins, CO. February 2016
- Hazen Research, Inc. 2010a. Roast-Leach Study of Metates Flotation Concentrates. Mudget, H Golden, CO. January 2010.
- Hazen Research, Inc. 2010b. Laboratory Investigation of Pressure Oxidation and Cyanidation of Metates Flotation Concentrates. Hazen Project 11002-01. Owusu, G, Golden, CO. April 2010.
- Hazen Research, Inc. 2011. Comminution Testing – Final Report, Hazen Project 11376. Golden, CO. November 2011.
- Hazen Research, Inc. 2012. Flotation Pilot Plant for Metates Ore. Hazen Project 11274. Golden, CO. 22 February 2012.
- Hazen Research, Inc. 2014a. Comminution Testing Report and Appendices A and B. Hazen Project 11938. Golden, CO. July 2014.
- Hazen Research, Inc. 2014b. Comminution Testing Report and Appendices A and B, Rev. 1. Hazen Project 11938. Golden, CO. September 2014.
- Hazen Research, Inc. 2015a. Bench-Scale Autoclave Study and Downstream Processing of Metates Concentrates, Rev.1 Report and Appendices A–H .Hazen Project 11581. Golden, CO. February 2015.
- Hazen Research, Inc. 2015b. Batch and Pilot Plant Work for the Metates Project Proposal and Appendices A-D, Rev. 1, 2015-105. Golden, CO. June 2015.
- Heiras y Asociados, S.C., 2013a, Title Opinion for American Gold Metates, S. de R.L. de C.V, Chihuahua, Mexico, October 31, 2013.
- Heiras y Asociados, S.C., 2013b, Title Opinion for Minerales El Prado, S.A. de C.V. , Chihuahua, Mexico, October 31, 2013.
- HydroGeoLogica, Inc. 2016a. Water Quality Database Handbook. Golden, CO. February 2016.

METATES SULPHIDE HEAP LEACH PROJECT - PHASE 1
FORM 43-101F1 TECHNICAL REPORT

- HydroGeoLogica, Inc. 2016b. Metates Project-Waste Rock Geochemistry and Field Barrel Testing Update. Golden, CO. March 2016.
- Hydromet (Pty) Ltd., Inc. 2013. High Level Comparison of Classical and FTR Pressure Oxidation Concentrate Testwork 2011-2012. Project H12/252. Riverfield, South Africa. November 2013.
- Hydromet (Pty) Ltd., Inc. 2015a. Description of Pressure Oxidation and Zinc Recovery Testwork. Riverfield, South Africa. July 2015.
- Hydromet (Pty) Ltd., Inc. 2015b. Description of Metal Recovery Methods. Riverfield, South Africa. July 2015.
- Hydromet (Pty) Ltd., Inc. 2015c. Phase 1 Process Design Basis & Criteria. Riverfield, South Africa. July 2015.
- Hydromet (Pty) Ltd., Inc. 2015d. Phase 2 Process Design Basis & Criteria. Riverfield South Africa. July 2015.
- IDE Technologies Ltd. 2015. Metates Desalination Plant - 55,000 m³/Day Indicative Proposal. Kadima, Israel. April 2015.
- Independent Mining Consultants, Inc. 2010. Metates Gold-Silver Project, Durango, Mexico, Preliminary Assessment—Mining. Prepared for Chesapeake Gold Corp. Tucson, AZ. April 2010.
- Independent Mining Consultants, Inc. 2013. Metates Gold Project, Durango, Mexico, Preliminary Feasibility Study – Mining. Tucson, AZ. June 2013.
- Independent Mining Consultants, Inc. 2015. Metates Gold Project, Durango, Mexico, Preliminary Feasibility Study – Staged Development Mining. Tucson, AZ. December 2015.
- Interralogic, Inc. 2013a. Baseline Geochemistry Report, Metates Project, Mexico. Project No. 100023. Fort Collins, CO. February 2013.
- Interralogic, Inc. 2013b. Preliminary Feasibility Study Level – Reclamation Plan, Metates Project, Mexico. Project No. 100023. Fort Collins, CO. February 2013.
- Interralogic, Inc. 2014. Climatology Analysis, Metates and Ranchito Sites, Durango and Sinaloa, Mexico Technical Memo. Ft. Collins, CO. August 2014.
- JKTech. 2014. SMC Test Report for Hazen Project 11938. Queensland, Australia. August 2014.
- Knight Piésold. 2014. El Paso Residue Tailings Geotechnical Laboratory Testing Results. Denver, CO. December 2014.
- KOHC, LLC. 2014. Metates Data Review-Comments Memo. Hoal, K. Golden, CO. 22 October 2014.
- M3 Engineering & Technology Corporation. 2010. NI-43-101 Technical Report, Metates Gold Silver Project, Preliminary Economic Assessment. Austin, D. and Ibrado, A. Tucson, AZ. June 2010.
- M3 Engineering & Technology Corporation. 2011. NI-43-101 Technical Report, Metates Gold Silver Project, Updated Preliminary Economic Assessment. Austin, D. and Ibrado, A. Tucson, AZ. April 2011.
- M3 Engineering & Technology Corporation. 2013. NI-43-101 Technical Report, Metates Gold-Silver Project, Preliminary Feasibility Study. Austin, D. and Ibrado, A. Tucson, AZ. March 2013.

METATES SULPHIDE HEAP LEACH PROJECT - PHASE 1
FORM 43-101F1 TECHNICAL REPORT

- M3 Engineering & Technology Corporation. 2016. NI-43-101 Technical Report, Metates Gold-Silver Project, Updated Preliminary Feasibility Study, Durango, Mexico, Sinaloa, Mexico. Austin, D. and Ibrado, A. April 29, 2016.
- M3 Mexicana. 2011a. Pre-factibilidad Ambiental del Proyecto El Ranchito, Cosalá, Sinaloa. México. Bennett, J. Hermosillo, MX. November 2011.
- M3 Mexicana. 2011b. Pre-factibilidad Ambiental del Proyecto Metates, Santiago Papasquiaro, Durango. Bennett, J. Tucson, AZ. November 2011.
- Method 1312 (SPLP), USEPA Publication SW-846, Test Methods for Evaluating Solid Waste, Physical/Chemical Methods.
- Montenegro, L. 2009. Metates Mining Project Analysis for Environmental Management, Environmental Impact Assessment Consulting Report. Mexico City, Mexico. 14 April 2009.
- Pace Global. 2013. Analysis of Power Supply Options for the Metates Gold Silver Project, Mexico. Fairfax, VA. February 2013.
- Pace Global. 2016. Review of Revised AES Non-Binding Proposal for Power Supply to Metates. Fairfax, VA. January 2016.
- Parkison, Ibrado, et al. 2014. Pressure Oxidation of Refractory Gold Ores: The Metates Gold Project Experience. Presented at the ALTA Conference. Perth, Australia. May 2014.
- Paterson & Cooke. 2010. Metates Project Ore and Concentrate Transport, Case 6A Executive Summary. Report No. KPM-5083 R28 Rev 1. Denver, CO. February 2010.
- Paterson & Cooke. 2013a. Concentrate and Water Supply Pipeline Systems: Concentrate Design Criteria. Report No. CGM-5255 R01a Rev 2. Golden, CO. January 2013.
- Paterson & Cooke. 2013b. Concentrate Pipeline System: Hydraulic Design and System Design Report. Report No. CGM-5255 R02 Rev 0. Golden, CO. January 2013.
- Paterson & Cooke. 2013c. Metates Concentrate Pipeline: Prefeasibility Study Cost Document. Report No. CGM-5255 R03 Rev 5. Golden, CO. January 2013.
- Paterson & Cooke. 2013d. Metates Tailings Dewatering. Report No. CGM-5254 R07 Rev A. Golden, CO. January 2013.
- Paterson & Cooke. 2013e. Metates Tailings Dewatering: Design Criteria. Report No. CGM-5254 R01 Rev A. Golden, CO. January 2013.
- Paterson & Cooke. 2013f. Metates Tailings Dry Stacking: Prefeasibility Cost Document. Report No. CGM-5254 R12 Rev A. Golden, CO. January 2013.
- Paterson & Cooke. 2013g. Metates Tailings Dry Stacking: Prefeasibility Study System Design and Description Report. Report No. CGM-5254 R13 Rev A. Golden, CO. January 2013.
- Paterson & Cooke. 2013h. Metates Tailings Large Filter Dewatering: Prefeasibility Study Cost Document. Report No. CGM-5254 R14 Rev 3. Golden, CO. January 2013.

METATES SULPHIDE HEAP LEACH PROJECT - PHASE 1
FORM 43-101F1 TECHNICAL REPORT

- Paterson & Cooke. 2013i. Metates Water Supply Pipelines: Prefeasibility Study Cost Document. Report No. CGM-5255 R05 Rev 2. Golden, CO. January 2013.
- Paterson & Cooke. 2013j. Ranchito Tailings Preparation and Delivery. Report No. CGM-5254 R08 Rev A. Golden, CO. January 2013.
- Paterson & Cooke. 2013k. Ranchito Tailings Preparation and Delivery: Design Criteria. Report No. CGM-5254 R06 Rev A. Golden, CO. January 2013.
- Paterson & Cooke. 2013l. Ranchito Tailings Preparation and Delivery: Prefeasibility Study Cost Document. Report No. CGM-5254 R15 Rev 2. Golden, CO. January 2013.
- Paterson & Cooke. 2014. Concentrate, Limestone and Water Supply Transport Systems-Metates Prefeasibility Alternate Studies. Report No. CGM-31-0450. Golden, CO. October 2014.
- Paterson & Cooke. 2015a. Concentrate Pipeline-2014 Prefeasibility Study Update. Report No. CGM-31-0472. Golden, CO. September 2015.
- Paterson & Cooke. 2015b. Metates Tailings De-Watering-2014 Prefeasibility Study Update. Report No. CGM-31-0472. Golden, CO. September 2015.
- Paterson & Cooke. 2015c. El Paso Tailings De-Watering-2014 Prefeasibility Study Update. Report No. CGM-31-0472. Golden, CO. September 2015.
- Paterson & Cooke. 2015d. Water Supply Pipeline Systems-2014 Prefeasibility Study Update. Report No. CGM-31-0472. Golden, CO. September 2015.
- Resource Development Incorporated (RDi). 2010. Metallurgical Testing of Samples from Metates Gold-Silver Project, Mexico. Allen, R.M. and Malhotra, D. Wheat Ridge, CO. April 2010.
- Resource Development Incorporated (RDi) 2012a. Metallurgical Testing of Variable Feed Samples. Allen, R.M. and Malhotra, D. Wheat Ridge, CO. 6 March 2012.
- Resource Development Incorporated (RDi) 2012b. Silver Recovery for the Metates Project. Allen, R.M. and Malhotra, D. Wheat Ridge, CO. June 2012.
- Schlumberger Water Services. 2010. Water Resource Evaluation Studies for the Metates Project—Technical Memorandum. Tucson, AZ. April 2010.
- Schlumberger Water Services. 2012. Strategies for Water Rights Development—Technical Memorandum. Tucson, AZ. September 2012.
- Schlumberger Water Services. 2013. Baseline Surface Water and Groundwater Monitoring Report. Tucson, AZ. September 2013.
- Sherritt Technologies. 2011a. Metates Gold Silver Project, Phase IIA Batch Test Work. Fort Saskatchewan, Alberta, Canada. July 2011.
- Sherritt Technologies. 2011b. Metates Gold Silver Project, Phase IIB Continuous Pilot Plant Test Work. Fort Saskatchewan, Alberta, Canada. August 2011.

METATES SULPHIDE HEAP LEACH PROJECT - PHASE 1
FORM 43-101F1 TECHNICAL REPORT

Sherritt Technologies. 2012. Metates Gold Silver Project, Zinc Recovery Test Work. Fort Saskatchewan, Alberta, Canada. March 2012.

SRK Consulting (Mexico). 2015. Preliminary Review of Options for Water Supply from a Desalinization Plant for the Metates Mining Project Technical Memo. Querétaro, Mexico. 10 December 2015.

SRK Consulting (US). 2016. Metates Project Site Wide Water Balance. Denver, CO. April 2016.

Woodward-Clyde. 1995. Initial Environmental Baseline Study for the Cambior Metates Gold Property, Mexico. Denver, CO. January 1995.

Zincobre Ingeniería, S.L.U. 2012. Metates Zinc Recovery Project, Mexico, Final Report, Project No. CLIP-PI-0403-R0000-TMR-00-02-RB. Asturias, Spain. 4 July 2012.

APPENDIX A: FEASIBILITY STUDY CONTRIBUTORS AND PROFESSIONAL QUALIFICATIONS

CERTIFICATE OF QUALIFIED PERSON

Justin Miles Black

I, Justin M. Black, P.E., do hereby certify that:

1. I am a Process Engineer of:

M3 Engineering & Technology Corporation
2051 W Sunset Rd, Tucson, AZ 85704

2. I graduated with a Chemical and Environmental Engineering degree from the University of Arizona.

3. I am a professional engineer in good standing in Arizona in the areas of chemical engineering.

4. I have worked as a process engineer for a total of 10 years. My experience includes project management, process design and optimization, project modeling and operations management.

5. I have read the definition of "Qualified Person" set out in National Instrument 43-101 ("NI 43-101") and certify that by reason of my education, affiliation with a professional association (as defined in NI 43-101) and past relevant work experience, I fulfill the requirements to be a "Qualified Person" for the purposes of NI 43-101.

6. I am principal author for the preparation of the technical report titled "Metates Sulphide Heap Leach Project - Phase 1, NI 43-101 Technical Report, Preliminary Economic Assessment", (the "Technical Report"), dated effective August 30, 2021, prepared for Chesapeake Gold Corp.; and am responsible for Sections 1.2-1.4, 1.10, 1.12- 1.15, 4, 5, 6, 9, 18, 19, 21 (except 21.1.3 and 21.2.3), 22, 23, 24, 25.1, 25.6, 25.7, 25.8, 26.5, 26.6. I have not visited the project site.

7. I have not had prior involvement with the property that is the subject of the Technical Report.

8. As of the date of this certificate, to the best of my knowledge, information and belief, the Technical Report contains all scientific and technical information that is required to be disclosed to make the Technical Report not misleading.

9. I am independent of the issuer applying all of the tests in Section 1.5 of National Instrument 43-101.

10. I have read National Instrument 43-101 and Form 43-101F1, and the Technical Report has been prepared in compliance with that instrument and form.

11. I consent to the filing of the Technical Report with any stock exchange and other regulatory authority and any publication by them, including electronic publication in the public company files on their websites accessible by the public, of the Technical Report.

Signed and dated this 30th day of August, 2021.

(Signed)

Signature of Qualified Person

Justin M. Black

Print Name of Qualified Person

CERTIFICATE OF QUALIFIED PERSON

I, Art S. Ibrado, PhD, PE, do hereby certify that:

1. I was employed as a project manager and metallurgist at M3 Engineering & Technology Corp., 2051 W Sunset Rd, Suite 101, Tucson, AZ 85704, USA, during the study. I am currently an independent metallurgical consultant with Fort Lowell Consulting PLLC, 5411 E Francisco Loop, Tucson, AZ 85712, USA.
2. I hold the following degrees:
 - Bachelor of Science in Metallurgical Engineering, University of the Philippines, 1980
 - Master of Science (Metallurgy), University of California, Berkeley, 1986
 - Doctor of Philosophy (Metallurgy), University of California, Berkeley, 1993
3. I am a registered professional engineer in the State of Arizona (No. 58140).
4. I have worked as a metallurgist in the academic and research setting for five years, excluding graduate school research, and in the mining industry for 13 years before joining M3 Engineering as a metallurgical engineer from May 2009 to July 2021.
5. I have read the definition of "Qualified Person" set out in National Instrument 43-101 ("NI 43-101") and certify that, by reason of my education, professional engineer registration, and past relevant experience, I fulfill the requirements to be a "Qualified Person" for the purposes of NI 43-101.
6. I am responsible for Sections 1.1, 1.6, 1.9, 2, 3, 13, 17, 25.4, 25.5, 26.3, 26.4, and 27 of the Technical Report titled "Metates Sulphide Heap Leach Project - Phase 1, NI 43-101 Technical Report, Preliminary Economic Assessment, Durango, Mexico" (the "Technical Report"), dated August 30, 2021, prepared for Chesapeake Gold Corp. I visited the Metates property on December 8, 2009.
7. As of the effective date of the Technical Report, to the best of my knowledge, information and belief, the parts of the Technical Report for which I am responsible contain all scientific and technical information that is required to be disclosed to make the Technical Report not misleading.
8. I am independent of Chesapeake Gold Corp. as independence is described in Section 1.5 of NI 43-101. I do not own any Chesapeake Gold Corp. stocks or shares.
9. My prior involvement with the Metates Project includes preparation of the Preliminary Economic Assessment (PEA) dated June 4, 2010 and updated on April 21, 2011. I was also involved with the preparation of the Metates Gold-Silver Project NI 43-101 Technical Report Preliminary Feasibility Study dated March 18, 2013, which was amended on October 31, 2013, and updated on April 29, 2016.
10. I have read National Instrument 43-101 and Form 43-101F1, and the Technical Report has been prepared in compliance with that instrument and form.
11. I consent to the filing of the Technical Report with any stock exchange and other regulatory authority and any publication by them for regulatory purposes, including electronic publication in the public company files on their website accessible by the public, of the Technical Report.

Dated this 30th Day of August 2021.

(Signed) (Sealed)

Art S. Ibrado, PhD, PE

CERTIFICATE OF QUALIFIED PERSON

I, Michael G. Hester, FAusIMM, do hereby certify that:

1. I am currently employed as Vice President and Principal Mining Engineer by Independent Mining Consultants, Inc. ("IMC") of 3560 E. Gas Road, Tucson, Arizona, 84714, USA.
2. I graduated with a Bachelor of Science degree in Mining Engineering from the University of Arizona in 1979 and a Master of Science degree in Mining Engineering from the University of Arizona in 1982.
3. I am a Fellow of the Australasian Institute of Mining and Metallurgy (FAusIMM #221108), a professional association as defined by National Instrument 43-101 – Standards of Disclosure for Mineral Projects ("NI 43-101").
4. I have worked in the minerals industry as an engineer continuously since 1979, a period of 42 years. I am a founding partner, Vice President, and Principal Mining Engineer for IMC, a position I have held since 1983. I have been employed as an Adjunct Lecturer at the University of Arizona (1997-1998) where I taught classes in open pit mine planning and mine economic analysis. I have also been a member of the Resources and Reserves Committee of the Society of Mining, Metallurgy, and Exploration since March 2012. During my career I have had extensive experience developing mineral resource models, developing open pit mine plans, estimating equipment requirements for open pit mining operations, developing mine capital and operating cost estimates, performing economic analysis of mining operations and managing various preliminary economic assessments, pre-feasibility, and feasibility studies.
5. I have read the definition of "qualified person" set out in NI 43-101 and certify that by reason of my education, affiliation with a professional association (as defined in NI 43-101) and past relevant work experience, I fulfill the requirements to be a "qualified person" for the purposes of NI 43-101.
6. I am responsible for Sections 1.5, 1.7, 1.8, 7, 8, 10, 11, 12, 14, 15, 16, 21.1.3, 21.2.3, 25.2, 25.3, 26.1 and 26.2 of the technical report titled "Metates Sulphide Heap Leach Project - Phase 1, NI 43-101 Technical Report, Preliminary Economic Assessment", (the "Technical Report"), dated effective August 30, 2021 and prepared for Chesapeake Gold Corp.
7. I have prior involvement with the property that is the subject of the Technical Report. This consists of work on the June 2009, June 2010, April 2011, October 2013, and April 2016 Technical Reports. IMC also did extensive work on the project for the Cambior Feasibility Study, though my personal involvement in that study was minimal. I last visited the Metates site on October 30, 2013 for one day. I also visited the site on April 24, 2009.
8. As of the date of this certificate, to the best of my knowledge, information, and belief, the Technical Report contains all scientific and technical information that is required to be disclosed to make the Technical Report not misleading.
9. I am independent of the issuer and its subsidiaries applying all the tests in Section 1.5 of NI 43-101.
10. I have read NI 43-101 and Form 43-101F1. The sections of the Technical Report that I am responsible for have been prepared in compliance with that instrument and form.
11. I consent to the filing of the Technical Report with any stock exchange and other regulatory authority and any publication by them, including electronic publication in the public company files on their website accessible by the public, of the Technical Report.

Dated this 30th day of August, 2021.

(Signed) _____

Signature of Qualified Person

Michael G. Hester, FAusIMM _____

Print Name of Qualified Person

CERTIFICATE OF QUALIFIED PERSON

Richard K Zimmerman, SME-RM

I, Richard K Zimmerman, R.G., SME-RM, do hereby certify that:

1. I am currently employed as Environmental Geologist by:

M3 Engineering & Technology Corporation
2051 W. Sunset Road, Ste. 101
Tucson, AZ 85704
2. I am a graduate of Carleton College and received a Bachelor of Arts degree in Geology in 1976. I am also a graduate of the University of Michigan and received a Master of Science degree in Geology in 1980.
3. I am a:
 - Registered Professional Geologist in the State of Arizona (No. 24064)
 - Registered Member in good standing of the Society for Mining, Metallurgy and Exploration, Inc. (No. 3612900RM)
4. I have practiced geology, mineral exploration, environmental remediation, and project management for 41 years. I have worked for mining and exploration companies for 9 years, engineering consulting firms for 22 years. The past 10 years have been spent with M3 Engineering & Technology Corporation managing, planning, and constructing processing plants for base and precious metals.
5. I have read the definition of “qualified person” set out in National Instrument 43-101 (“NI 43-101”) and certify that by reason of my education, affiliation with a professional association (as defined in NI 43-101) and past relevant experience, I fulfill the requirements to be a “qualified person” for the purposes of NI 43-101.
6. I am responsible for Sections 1.11 and 20 of the technical report “Metates Sulphide Heap Leach Project - Phase 1, NI 43-101 Technical Report, Preliminary Economic Assessment” (the “Technical Report”) dated effective August 30, 2021, prepared for Chesapeake Gold Corp.
7. I have had prior involvement with the property that is the subject of the Technical Report. I was involved in the preparation of both the “Metates Gold-Silver Project NI 43-101 Technical Report Preliminary Feasibility Study” dated March 18, 2013, amended October 31, 2013, and the “Metates Gold-Silver Project, NI 43-101 Technical Report, Updated Preliminary Feasibility Study, Durango, Mexico, Sinaloa, Mexico” dated effective April 29, 2016.
8. I have not visited the Metates site.
9. As of the date of this certificate, to the best of my knowledge, information and belief, the parts of the Technical Report for which I am responsible contain all scientific and technical information that is required to be disclosed to make the Technical Report not misleading.
10. I am independent of the issuer applying all tests in Section 1.5 of National Instrument 43-101.
11. I have read National Instrument 43-101 and Form 43-101F1, and the Technical Report has been prepared in compliance with that instrument and form.

12. I consent to the filing of the Technical Report with any stock exchange and other regulatory authority and any publication by them of the Technical Report for regulatory purposes including electronic publication in the public company files on their websites accessible by the public.

Dated this 30th day of August 2021.

(Signed) (Sealed)

Richard K. Zimmerman, M.Sc., R.G., SME-RM